

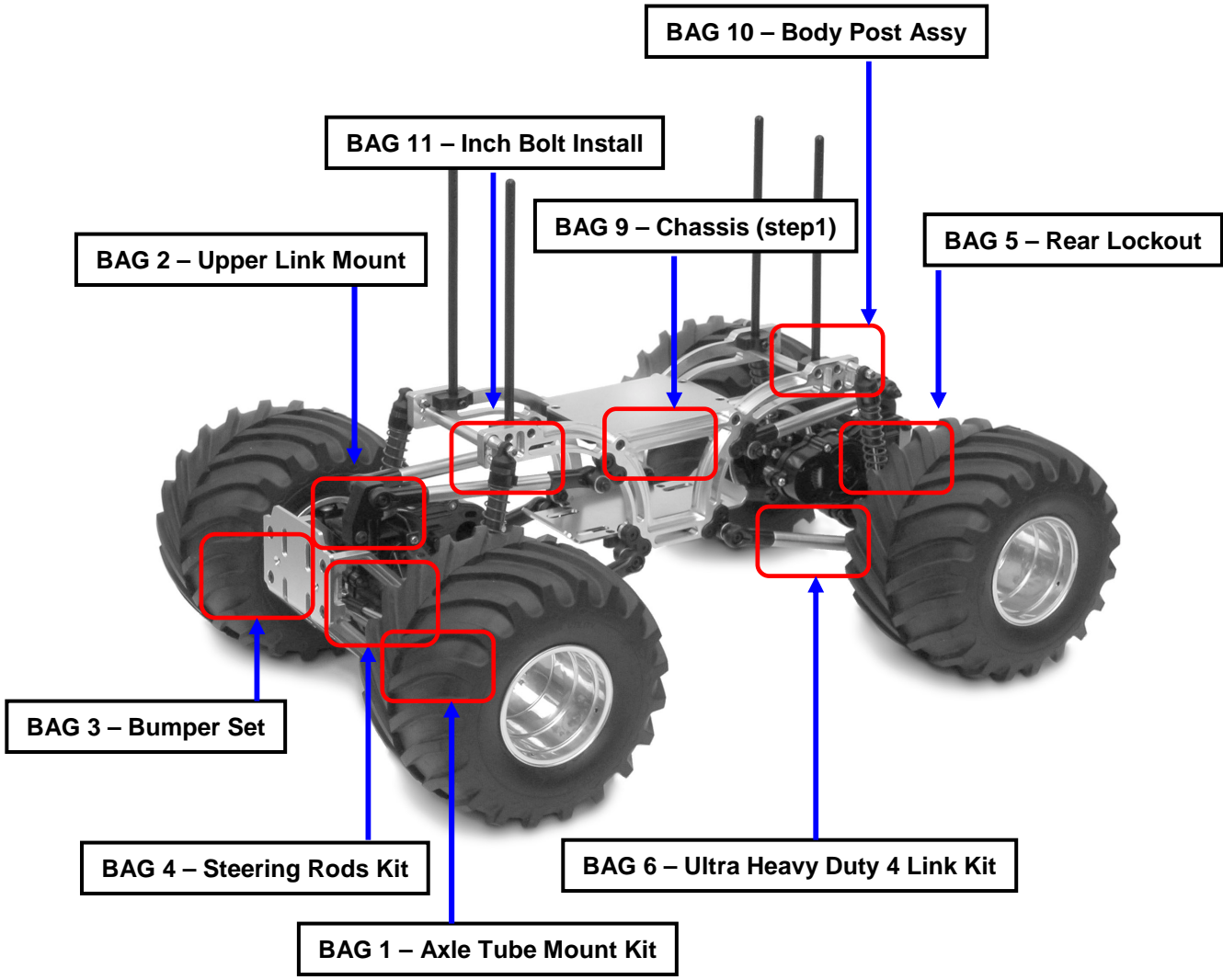

Red window Click - > serial section



DRAGOON

GMC - 50200

DRAGOON

GMC - 50200



Step 1.

Tools

1. Supplied

1.1 Allen wrenches

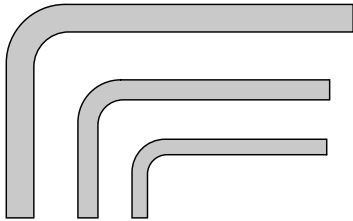

2. Stuff Needed

2.1 Screwdriver (+)

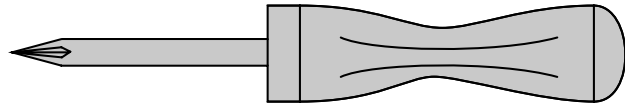

2.2 Needlenose Pliers

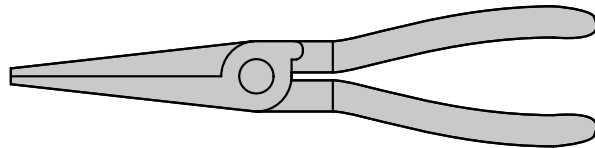

2.3 Precision ruler



2.4 Thread lock

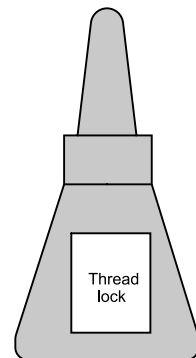

2.5 Hack Saw



2.6 Hobby Knife



2.7 Drill



1. *WARNING!*

1.1 Hobby knife : This Knife cuts plastic and fingers with equal ease, so be careful.

1.2 Power screwdriver : Do not use a power screwdriver to install screws into M/C nylon, materials. They can then break the M/C nylon parts or strip the threads during installation.

2. Before Building**2.1 Open the bags in order**

The assembly is arranged so that you will open and finish that bag before you go on to the next bag. sometimes you will have parts remaining at the end of a bag.

Step 3.

BAG 1 – Axle Tube Mount Kit



GMC - 50101-S

1. M/C Nylon Part(L)
GMC - 50111 X 2
 2. M/C Nylon Part (R)
GMC - 50112 X 2
 3. SUS Brace
GMC - 50113 X 4
 4. Sway bar spacer
GMC - 50114 X 4
 5. 2.5mm Spacer
GMC - 50115 X 4
 6. 4mm Spacer
GMC - 50116 X 4
- Bolt, Nut**
GMC - 50101-B

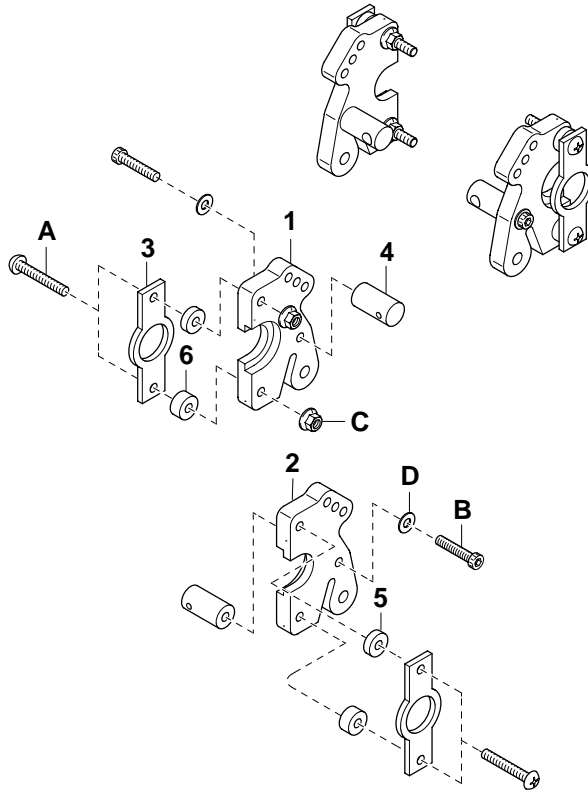

A. 3X20 Round Head X 8



B. 3 X 15 Cab Head X 4 (Sway bar spacer)



C. M3 Flange Nut X 8



D. M3 Washer X 4



CAUTION !!

Drilling

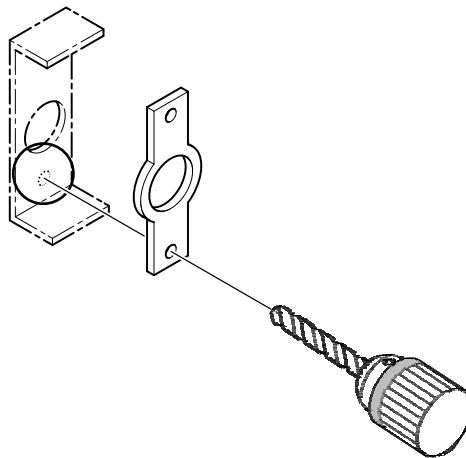

Step 4.

BAG 2 – Upper Link Mount



GMC - 50102-S

1. M/C Nylon Part
GMC - 50121 X 2
2. 22mm Spacer
GMC - 50122 X 2
- Bolt Nut**
GMC - 50102-B

A. 4 X 30 Cab Head X 2

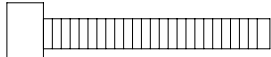

B. M4 Washer X 2



C. 3 X 35 Cab Head X 2

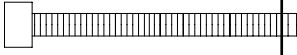

D. M3 Washer X 2



E. M3 Flange Nut X 2

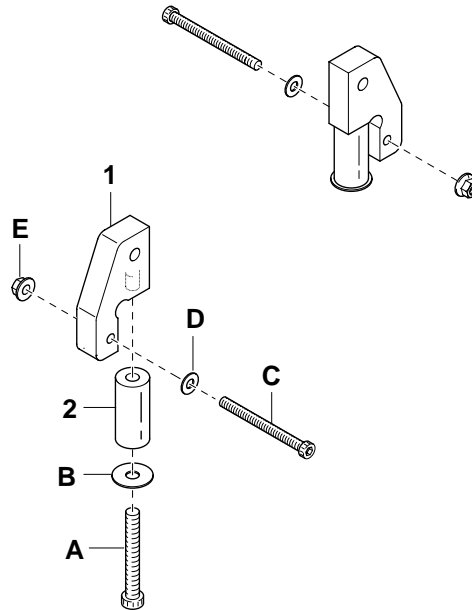

Step 5.

BAG 3 – Bumper Set



GMC - 50103-S

1. Bumper Guard (L)
GMC - 50131 X 1
2. Bumper Guard (R)
GMC - 50132 X 1
3. Skid Plate
GMC - 50133 X 1
4. 2.5mm Spacer
GMC - 50115 X 1
5. 4mm Spacer
GMC - 50116 X 2
6. 12.5mm Spacer
GMC - 50134 X 1
- Bolt, Nut**
GMC - 50103-B

A. 3X30 Cab Head X 1



B. 3X20 Cab Head X 6



C. 3X18 Cab Head X 1



D. 4X10 Flat Head X 4



E. 3X12 Flat Head X 2



F. M3 Flange Nut X 8

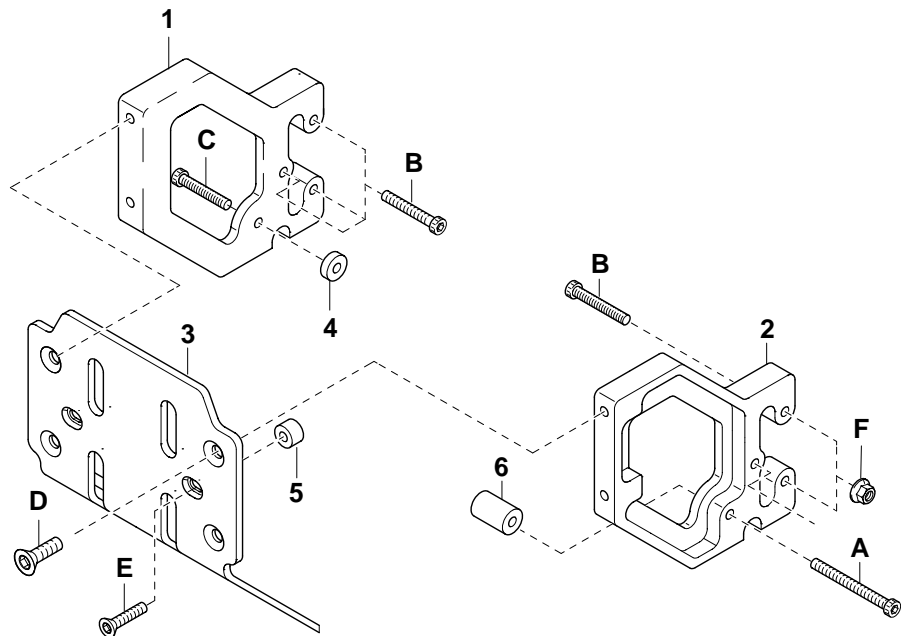

Step 6.

BAG 4 – Steering Rods Kit



GMC - 50104-S

1. 47mm Steering Rods
GMC - 50141 X 2
 2. 129mm Steering Rods
GMC - 50142 X 2
 3. 6.8 ϕ Flanged Ball
GMC - 50144 X 8
 4. 6.8 ϕ Ball end
GMC - 50143 X 8
- Bolt, Nut**
GMC - 50104-B

A. 3X15 Cab Head X 2

B. 3 X 20 Cab Head X 2

C. 3 X 25 Cab Head X 2

D. M3 Nut X 8

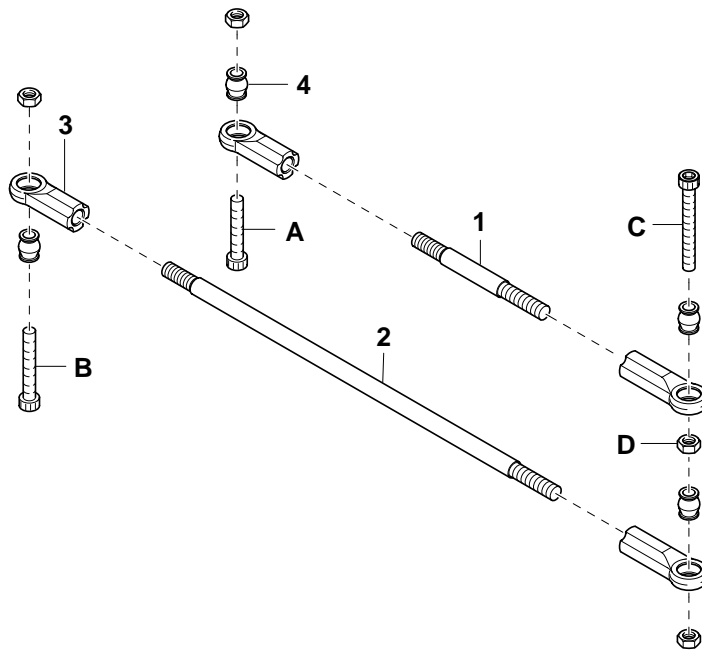

Step 7.

BAG 5 – Rear Lockout



GMC - 50105-S

1. Rear Lock Holder
GMC - 50151
 2. Steering Load Set
 3. 6.8 ϕ Flange Ball
GMC - 50143
- Bolt, Nut**
GMC - 50105-B

A. 3X15 Cab Head X 1

B. 3 X 18 Cab Head X 2

C. M3 Nut

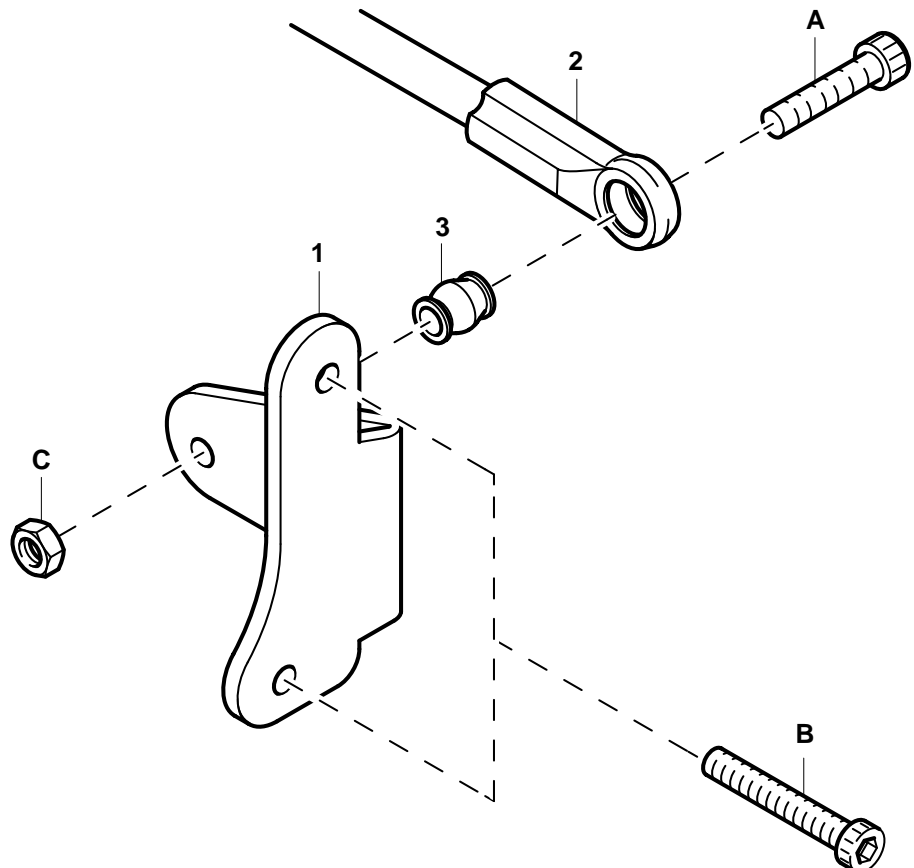

Step 8.

BAG 6 – Ultra Heavy Duty 4 Link Kit



GMC - 50206-S

1. Upper Link
GMC - 50261 X 4
2. Lower Link
GMC - 50262 X 4
3. 10 \varnothing ball end
GMC - 50164 X 16
Bolt, Nut
GMC - 50106-B

A. 5X25 wrenches Bolt
X 16

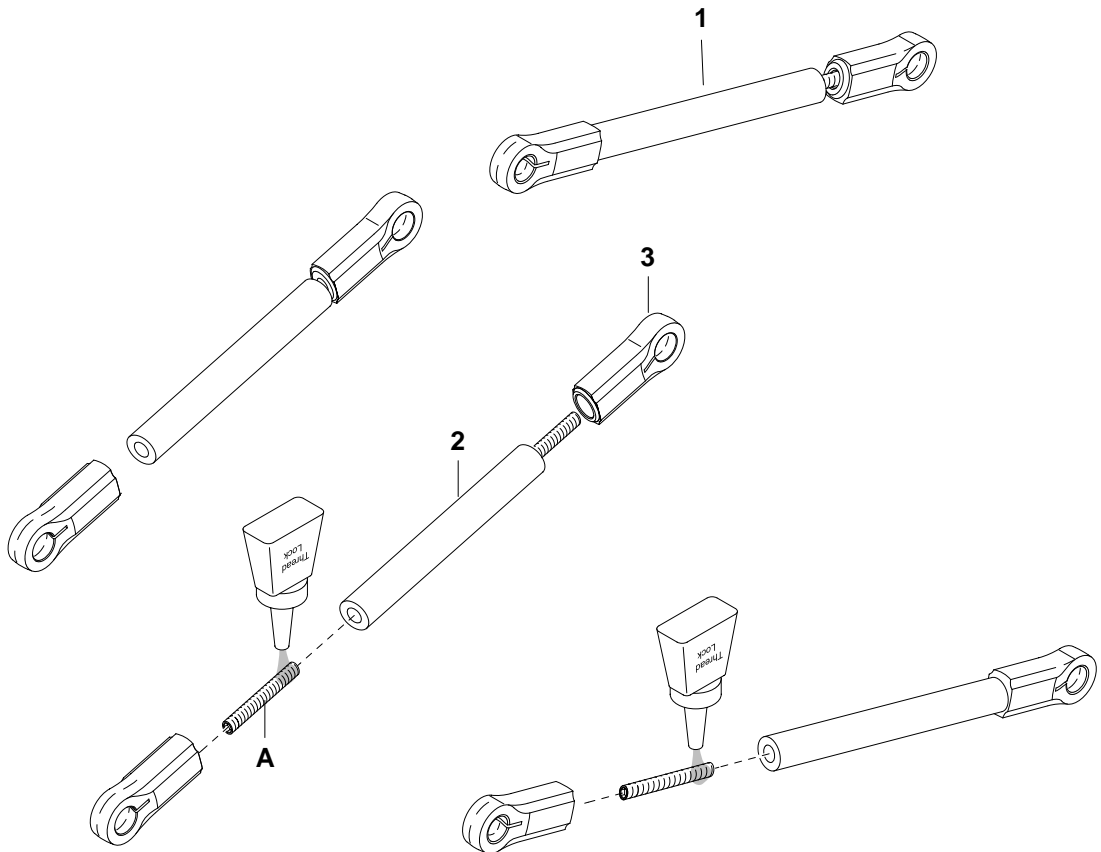

Step 9.

BAG 7 – Radio Plate



GMC - 50207-S

1. Radio Plate
GMC - 50172
2. Radio Plate Mount
GMC - 50272 X 2
Bolt, Nut
GMC - 50207-B

A. 3X10 Flat Head X 4

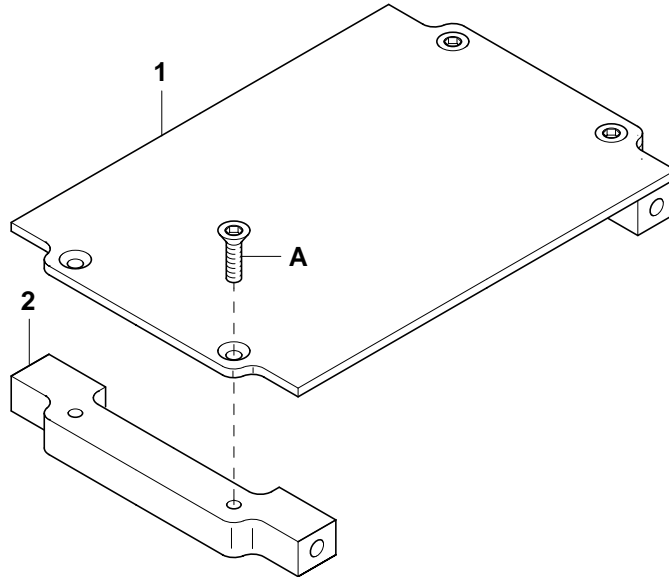

Step 10.

BAG 8 – Battery Plate



GMC - 50207-S

1. Battery Plate
GMC - 50173
2. Battery Plate Mount
GMC - 50176 X 2
3. Sway Bar
GMC - 50275 X 2
Bolt, Nut
GMC - 50207-B

A. 3X10 Flat Head X 4

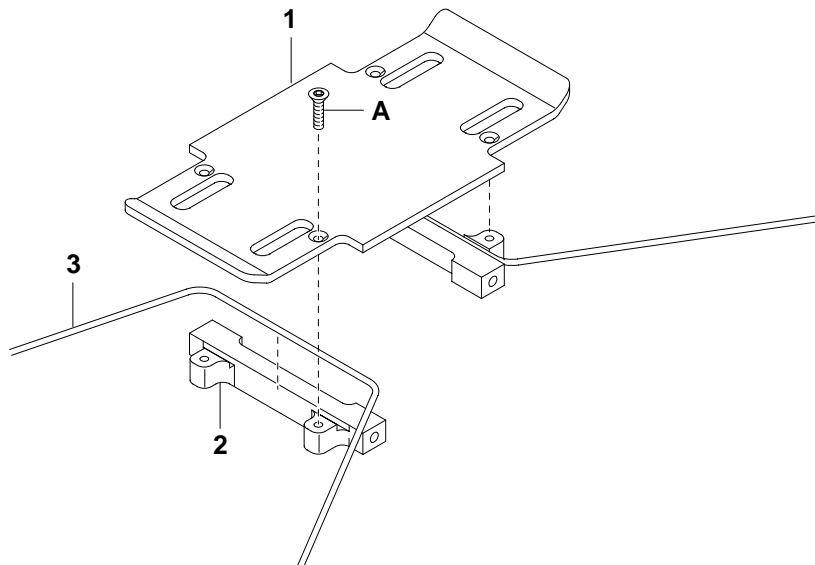

Step 11.

BAG 9 – Chassis (step1)



GMC - 50207-S

1. Main Chassis
GMC - 50271 X 2
2. Chassis link Mount
GMC - 50174 X8
Bolt, Nut
GMC - 50207-B

A. 4X15 Flat Head X 12



B. M4 Flange Nut X 12

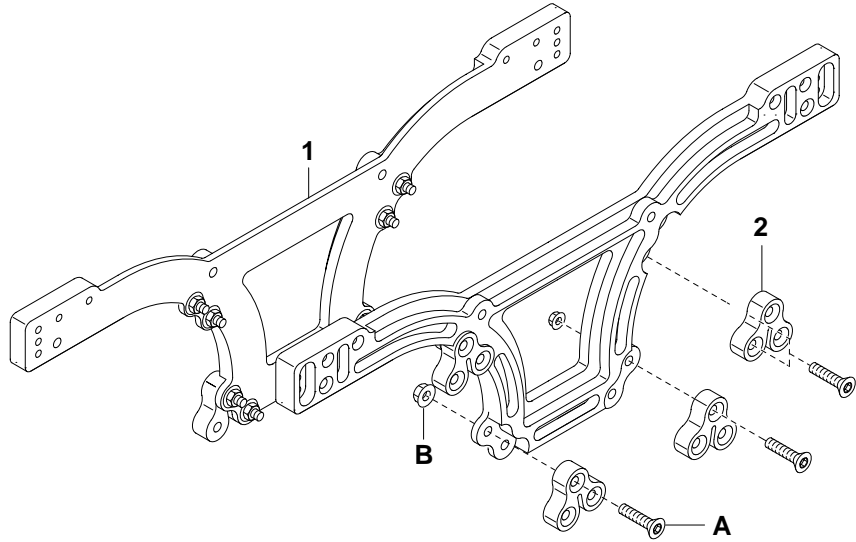

Step 12.

BAG 9 – Chassis (step2)



GMC - 50207-S

1. Main Chassis Assy
2. Radio Plate Assy
3. Battery Plate Assy

Bolt, Nut
GMC - 50207-B

A. 4X20 Flat Head X 4



B. 4X12 Cab Head X 4

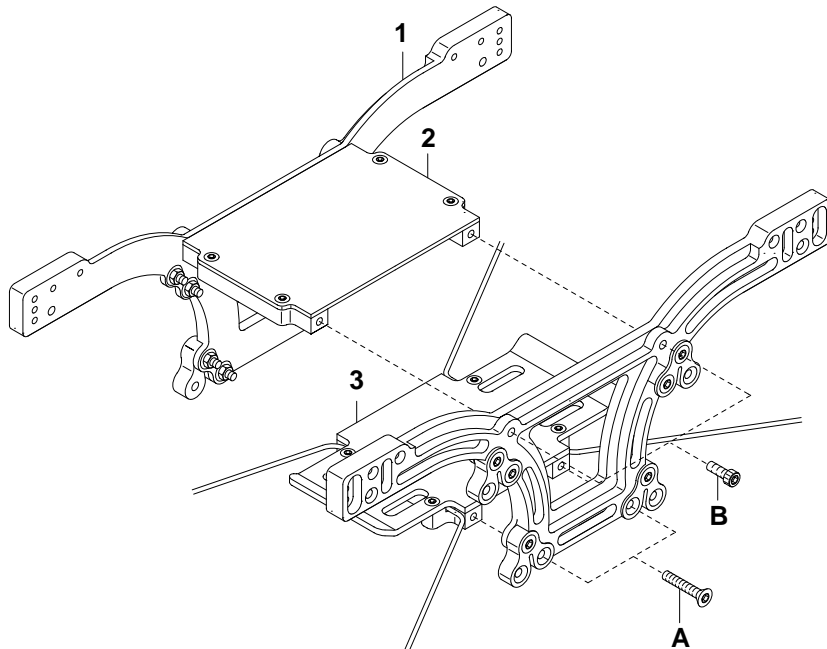
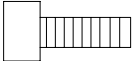

Step 13.

BAG 9 – Chassis (step3)



GMC - 50207-S

1. Main Chassis Assy
2. Lower LINK
3. 10 \varnothing ball
GMC - 50163 X 4
Bolt, Nut
GMC - 50106-B

A. 4X20 Cab Head X 4



B. M4 Flange Nut X 4

C. M4 Washer X 4

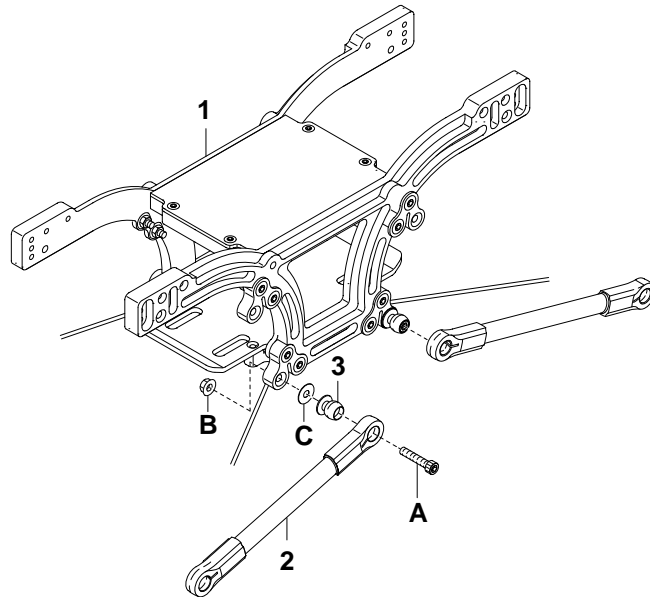

Step 14.

BAG 9 – Chassis (step4)



GMC - 50207-S

1. Main Chassis Assy
2. Upper Link
3. 10 \varnothing ball
GMC - 50163 X 4
Bolt, Nut
GMC - 50106-B

A. 4X20 Cab Head X 4



B. M4 Flange Nut X 4

C. M4 Washer X 4

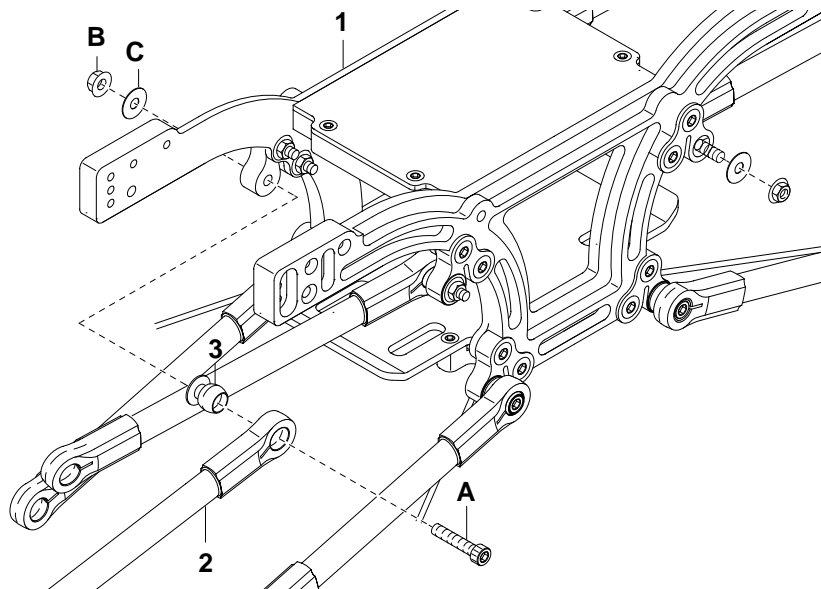

Step 15.

BAG 9 – Chassis (step5)



GMC - 50207-S

1. Main Chassis Assy
2. Upper LINK Mount
3. 10 ϕ ball
GMC - 50163 X 4
4. 7mm Spacer
GMC - 50165 X 2
Bolt, Nut
GMC - 50106-B

A. 4X40 Cab Head X 2

B. M4 Flange Nut X 4

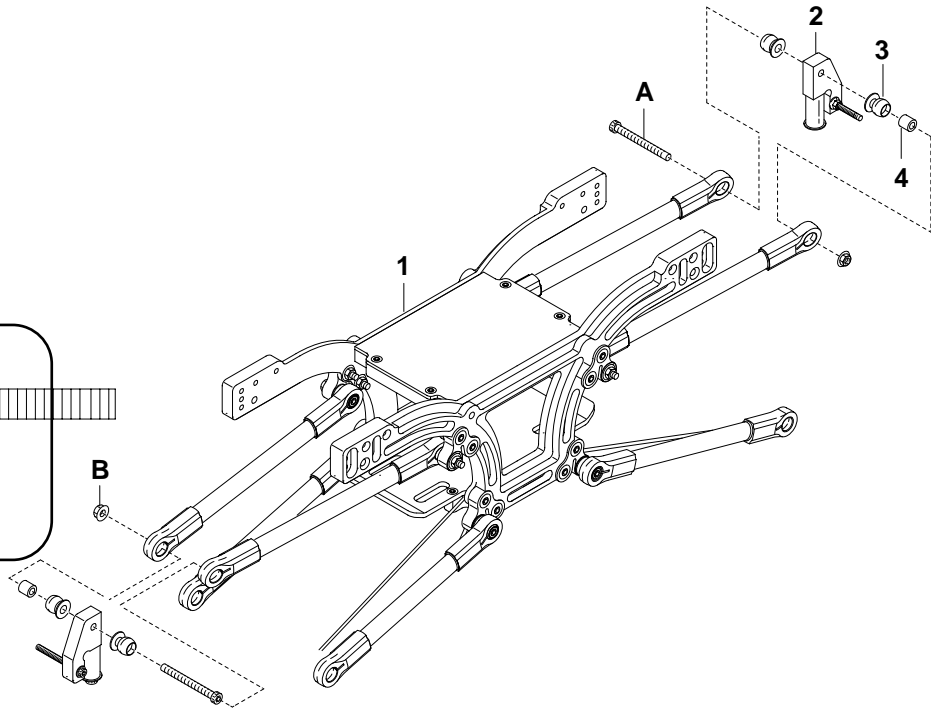
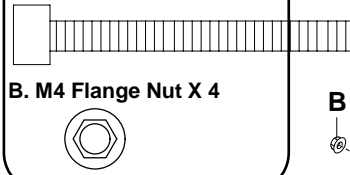

Step 16.

BAG 9 – Chassis (step6)



GMC - 50207-S

1. Main Chassis Assy
2. Axle Tube Brace assy
3. Sway bar spacer
GMC - 50114 X 4
4. 10 ϕ ball
GMC - 50163 X 4

Bolt, Nut
GMC - 50106-B

A. 4X20 Cab Head X 4

B. M4 Flange Nut X 4

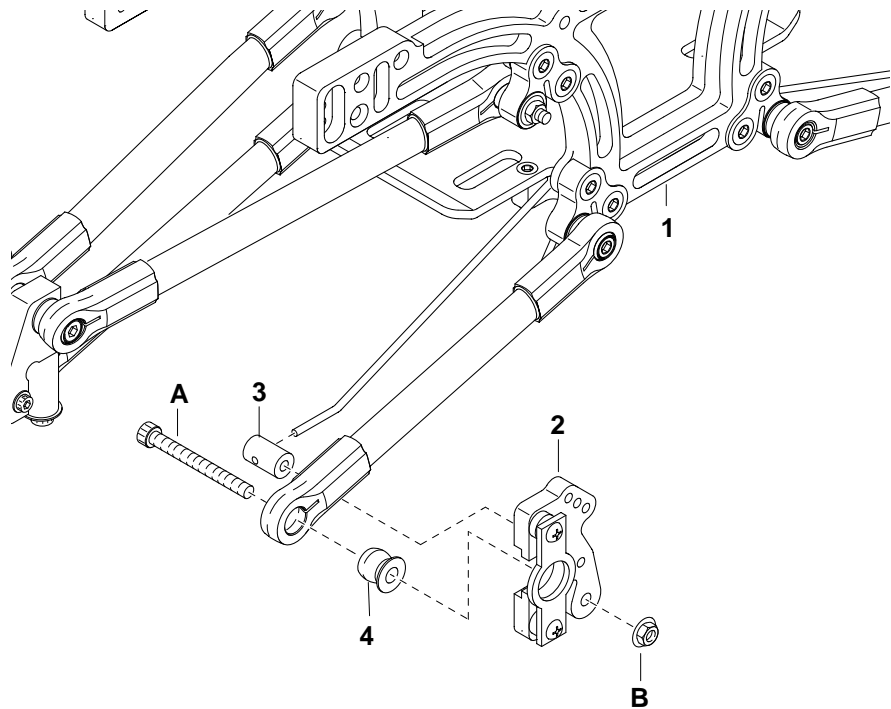
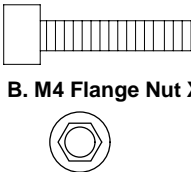

Step 17.

BAG 10 – Body Post Assy



GMC - 50207-S

- 1. Main Chassis Assy
- 2. Body Post Mount
GMC - 50273 X4
- 3. Chassis Shaft
GMC - 50274 X 2
- 4. Body Post
GMC - 50178 X 4
Bolt, Nut
GMC - 50207-B

A. 3X8 Round Head X 4

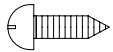

B. 4X12 cab Head X 4

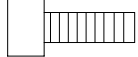

C. 3X10 cab Head X 4

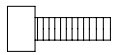

D. Cable Tie X 2

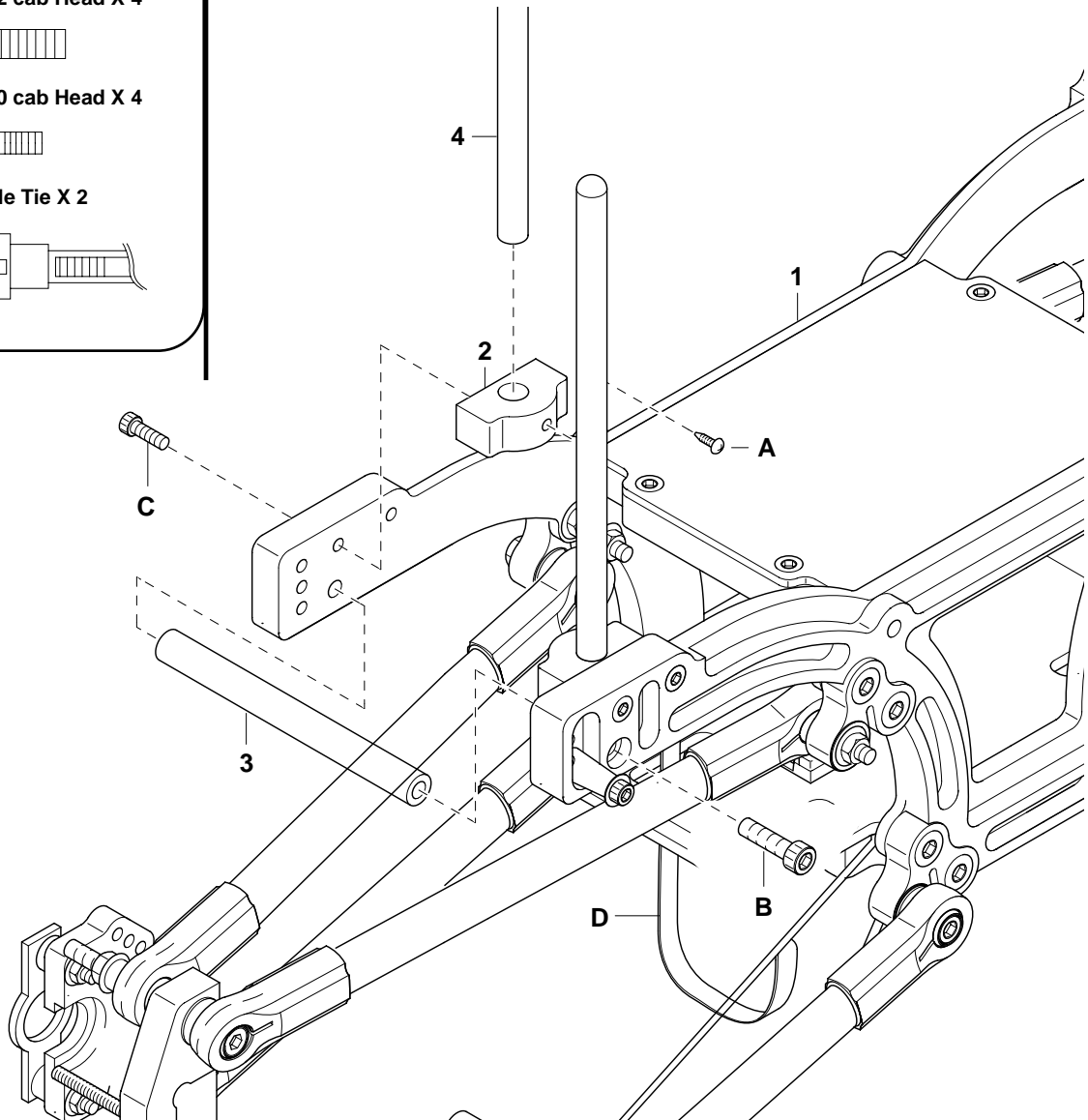
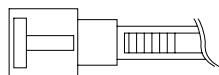

Step 18.

BAG 11 – Inch Bolt Install



GMC - 50207-S

- 1. Main Chassis Assy
- 2. Shock Mount
GMC - 50179 X4
- 3. 4mm Spacer
GMC - 50116 X 4
Bolt, Nut
GMC - 50207-Bi

A. #4 X 40 X 1" X 4



B. #4 X 40 X 1 1/4" X 4



C. M3 Washer X 8



D. #4 Nylon Nut X 8



E. #4 Nylon Nut X 8

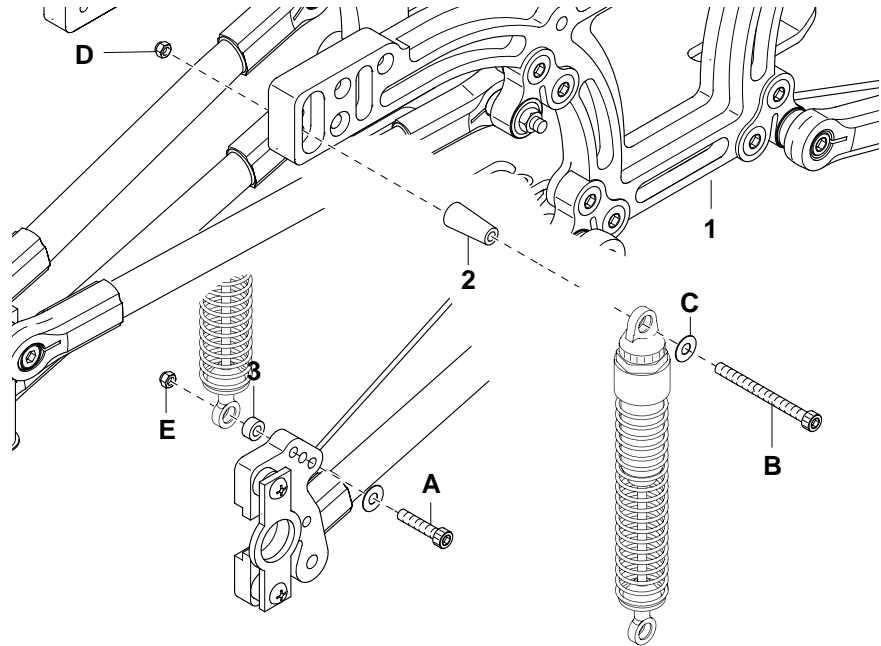

CAUTION !!

Shock Assy

Moving Free

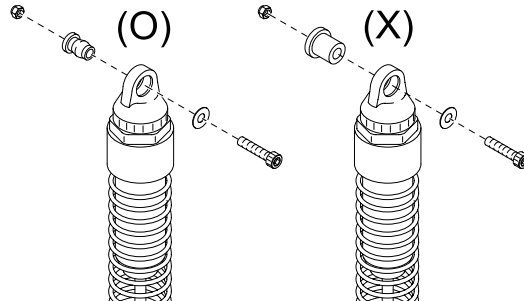
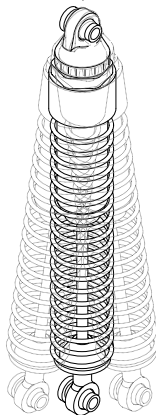

Step 19.

Note

1. Servo Assy

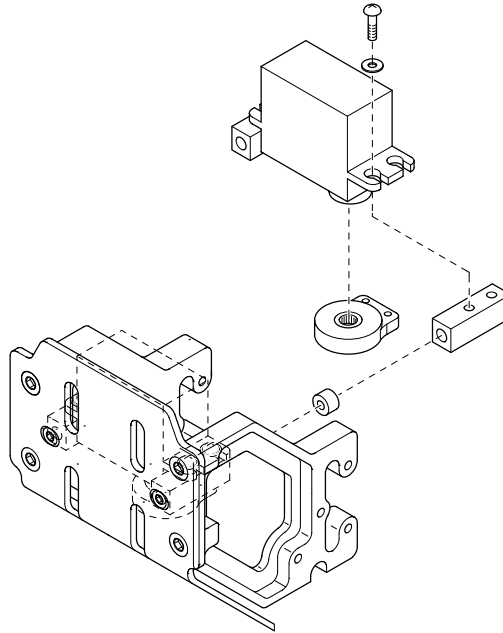
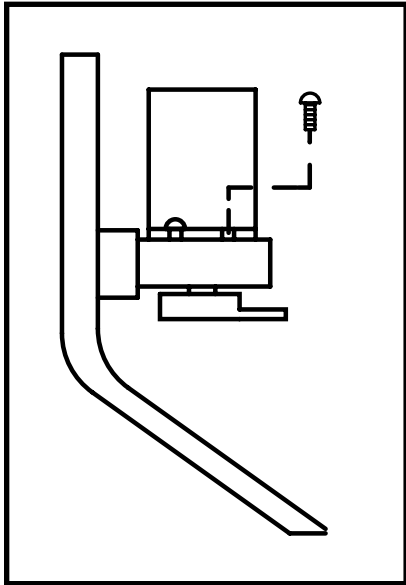

2. Body post Assy

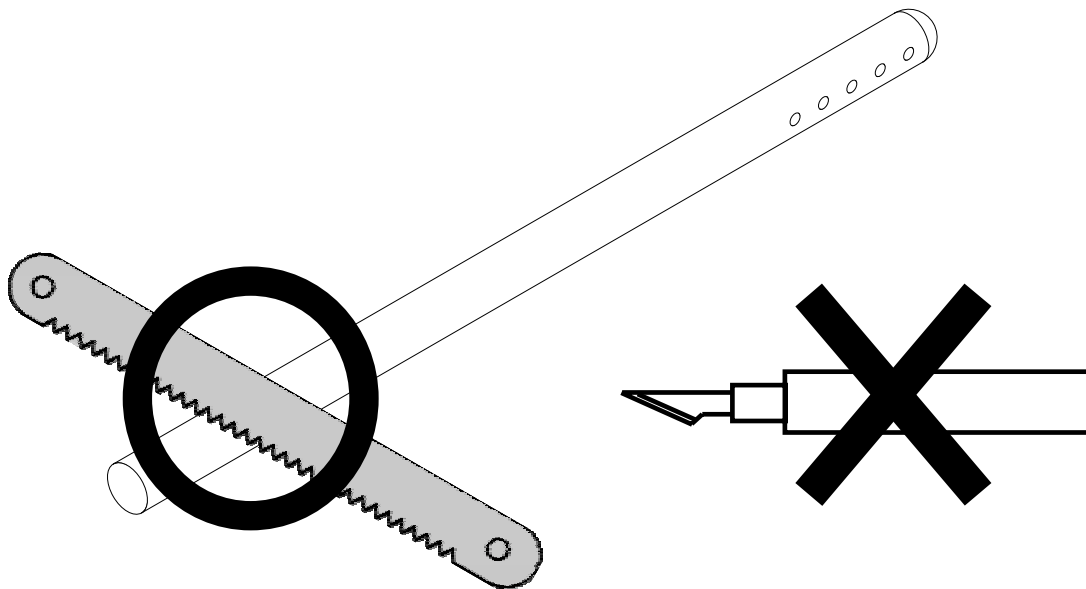



Bag GMC-50101S / 50101B

NO.	PART	DESCRIPTION	Q'TY
1	GMC - 50111	M/C Nylon Part (L)	2
2	GMC - 50112	M/C Nylon Part (R)	2
3	GMC - 50113	SUS Brace	4
4	GMC - 50114	Sway bar spacer	4
5	GMC - 50115	2.5mm Spacer	4
6	GMC - 50116	4mm Spacer	4
7			
8			
9			
10			
A		3X20 Round Head	8
B		3 X 15 Cab Head	4
C		M3 Flange Nut	8
D		M3 Washer	4
E			
F			
G			
H			
I			
J			
K			
L			
M			
N			



Bag GMC- 50102S / 50102B

NO.	PART	DESCRIPTION	Q'TY
1	GMC - 50121	M/C Nylon Part	2
2	GMC - 50122	22mm Spacer	2
3			
4			
5			
6			
7			
8			
9			
10			
A		4 X 30 Cab Head	2
B		M4 Washer	2
C		3 X 35 Cab Head	2
D		M3 Washer	2
E		M3 Flange Nut	2
F			
G			
H			
I			
J			
K			
L			
M			
N			



Bag GMC-50103S / 50103B

NO.	PART	DESCRIPTION	Q'TY
1	GMC - 50131	Bumper Guard (L)	1
2	GMC - 50132	Bumper Guard (R)	1
3	GMC - 50133	Skid Plate	1
4	GMC - 50115	2.5mm Spacer	1
5	GMC - 50116	4mm Spacer	2
6	GMC - 50134	12.5mm Spacer	1
7			
8			
9			
10			
A		3X30 Cab Head	1
B		3X20 Cab Head	6
C		3X18 Cab Head	1
D		3X12 Cab Head	2
E		3X12 Flat Head	2
F		M3 Flange Nut	8
G		4X10 Flat Head	4
H			
I			
J			
K			
L			
M			
N			



Bag GMC-50104S / 50104B

NO.	PART	DESCRIPTION	Q'TY
1	GMC - 50141	47mm Steering Rods	2
2	GMC - 50142	129mm Steering Rods	2
3	GMC - 50144	6.8 ø Flanged Ball	8
4	GMC - 50143	6.8 ø Ball end	8
5			
6			
7			
8			
9			
10			
A		3X15 Cab Head	2
B		3 X 20 Cab Head	2
C		3 X 25 Cab Head	2
D		M3 Nut	8
E			
F			
G			
H			
I			
J			
K			
L			
M			
N			



Bag GMC-50105S / 50105B

NO.	PART	DESCRIPTION	Q'TY
1	GMC - 50151	Rear Lock Holder	1
2			
3			
4			
5			
6			
7			
8			
9			
10			
A		3 X18 Cab Head	2
B			
C			
D			
E			
F			
G			
H			
I			
J			
K			
L			
M			
N			



Bag GMC-50206S / 50206B

NO.	PART	DESCRIPTION	Q'TY
1	GMC - 50261	Upper Link	4
2	GMC - 50262	Lower Link	4
3	GMC - 50163	10 ø ball	16
4	GMC - 50164	10 ø ball end	16
5	GMC - 50165	7mm Spacer	2
6			
7			
8			
9			
10			
A		5X25 wrenches Bolt	16
B		M 4 X 20 Cab Head	12
C		M 4 X 40 Cab Head	2
D		M4 Flanged Nut	12
E		M4 Washer	8
F			
G			
H			
I			
J			
K			
L			
M			
N			



Bag GMC-50207S / 50207B

NO.	PART	DESCRIPTION	Q'TY
1	GMC -50271	Main Chassis	2
2	GMC - 50172	Radio Plate	1
3	GMC - 50173	Battery Plate	1
4	GMC - 50174	Chassis link Mount	8
5	GMC - 50272	Radio Plate Mount	2
6	GMC - 50176	Battery Plate Mount	2
7	GMC - 50275	Sway Bar	2
8	GMC - 50178	Body Post	4
9	GMC - 50179	Shock Mount Spacer	4
10	GMC - 50273	Body Post Mount	4
11	GMC - 50274	Chassis Shaft	2
12	GMC - 50116	4mm Spacer	4
A		3 X 8 Round Head Screw	4
B		M3 X 10 Cab Head	8
C		M4 X 12 Cab Head	8
D		M3 X 10 Flanged Head	8
E		M4 X 15 Flanged Head	12
F		M4 X 20 Flanged Head	4
G		M4 Flanged Nut	12
H		#4 X 40 X 1 ¼"	4
I		#4 X 40 X 1"	4
J		M3 Spring Washer	8
K		M3 Washer	8
L		#4 Nut	8
M		#4 Nylon Nut	8
N			
O			

D R A G O O N

GMC - 50200

