



STEALTH

GMC-50300

STEALTH

GMC - 50300



## Tool

1. Supplied
  - ① Allen wrenches #50132 (1.5, 2.5, 3, 5mm)
  - ② Box wrenches #50132 (7,8mm)
2. Stuff Needed
  - ① Screwdriver (+)
  - ② Needlenose pliers
  - ③ precision ruler
  - ④ Hack saw
  - ⑤ Hobby knife
  - ⑥ Thread lock
  - ⑦ Gear grease

### WARNING!

Hobby knife : This Knife cuts plastic and fingers with equal ease, so be careful.

## Equipment

1. Items needed to complete your car
  1. Radio system
  2. Servo (4WS/ tow servos)
  3. Servo saver
  4. Electronic speed control
  5. Two electric motors
  6. Battery pack (6 cell)
  7. Battery charger
  8. Shock set (4ea)
  9. 1/10 Scale truck body

Customer support

<http://www.gmade.net>

E-mail [gm@gmade.net](mailto:gm@gmade.net)

## Stealth PART LIST

BAG 20101	
20101	Upper differential gearbox (X2)
20101	Lower differential gearbox (X2)
20101	Pinion gear cover (X2)
20102	Axle stay(L) (X2)
	Axle stay(R)(servo) (X2)
20103	motor spacer (X4)
20104	servo mount (X4)
20105	Drive shaft (short) (X2)
	Drive shaft (long) (X2)
	4X30 Hex screw (X4)
	3X10 Hex screw (X4)
	3X20 Hex screw (X2)
	3X25 Round head screw (X4)
	3X8 Tapping screw (X8)
	3X15 Tapping screw (X4)
	6mm E-Ring (X8)
	4mm Nut (X4)
	3mm Nut (X6)
3mm Washer (X4)	

BAG 20141	
20141	36T Counter gear (36/14t) (X2)
	48T Counter gear (48/14t) (X2)
	36T Counter gear shaft (X2)
	48T Counter gear shaft (X2)
	3X5 Hex screw (X2)
	3X8 Hex screw (X2)
	3mm Washer (X4)
20142	3X3 Grub screw (X2)
	Pinion gear (12t) (X2)

BAG 20151	
20151	Knuckle arm (X4)
20152	Kingpin (X8)
	4mm Washer (X8)

BAG 20111	
20111	Axle guard (L) (X2)
	Axle guard (R) (X2)
20112	Axle guard shaft (long) (X4)
	Axle guard shaft (short) (X2)
20111	3X10 Hex screw (X4)
	3X40 Hex screw (X6)
	3mm Nut (X6)

BAG 20121	
20121	Axle mount (L) (X2)
	Axle mount (R) (X2)
	3X40 Hex screw (X8)
	3mm Nut (X8)

BAG 20131	
20131	Differential gear (42t) (X2)
	Large bevel gear (15t) (X4)
	Small bevel gear (8t) (X6)
	Differential cover (X4)
	Small bevel gear shaft (X6)
	2.6X8 Flat head screw (X12)
	O-Ring (X4)

BAG 50310	
50310	Chassis (L) / (R)
50311	Chassis Cover
50111	Battery plate
50112	Radio plate
50113	Body post (X4)
50114	Body post mount (X4)
50315	3mm Nut (X4)
	4mm Nut (X8)
	3X10 M3 Hex screw (X8)
	3X20 M3 Hex screw (X4)
	3X30 M3 Hex screw (X4)
	4X10 M4 Hex screw (X14)
	4X30 M4 Hex screw (X8)
	3mm Flange nut (X8)
	3mm Nylon lock nut (X8)
	M4 Flange nut (X6)
50116	Snap pin (X12)
50117	Shock mount (X4)
50316	Chassis Shaft 84mm (X4)
50317	Chassis Shaft 20mm (X8)

20001	Ultrac Tire (X4)
20042	Black Wheel (X4)
20020	5mm Wheel Block locknut (X4)

BAG 20161	
20161	Wheel axle (X4)
20162	Wheel hub (12m/m) (X4)
20163	Wheel hub (14m/m) (X4)
20164	6mm E-ring (X4)

BAG 20171	
20171	Threaded shaft (long) (X2)
	Threaded shaft (short) (X2)
20172	6.8 rod end (X8)
	6.8 ball (X8)
20171	3X15 Hex screw (X2)
	3X20 Hex screw (X2)
	3X25 Hex screw (X2)
	3mm Nut (X6)

BAG 20181	
20181	Ball bearing 12X8X3.5 (X16)
	Ball bearing 10X5X4 (X4)
	Ball bearing 8X5X2.5 (X4)

BAG 50320	
50320	Upper rod (X4)
50321	Lower rod (X4)
50122	10mm Rod end (X16)
50123	10mm Ball (X16)
50324	5X25 Socket Set screw (X16)
	4mm Nut (X4)
	4mm Flange nut (X12)
	4x15 Hex screw (X8)
	4X20 Hex screw (X4)
	4X30 Hex screw (X4)

BAG 50130	
50130	Releasable tie (X2)
50131	Velcro strap (X2)
50132	1.5mm Allen wrench
	2.5mm Allen wrench
	3mm Allen wrench
	5mm Allen wrench
	Box wrench

# STEP. 1

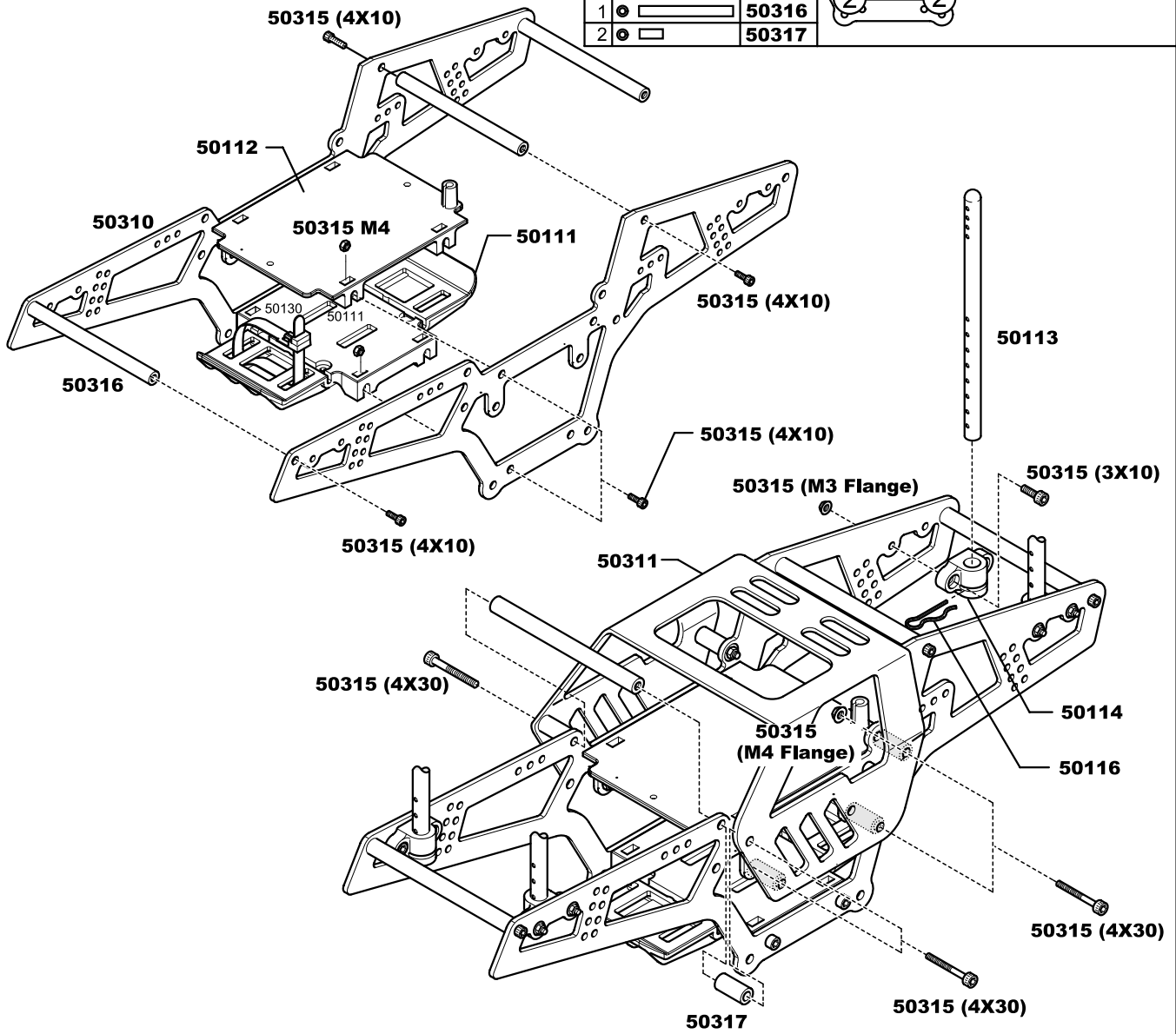
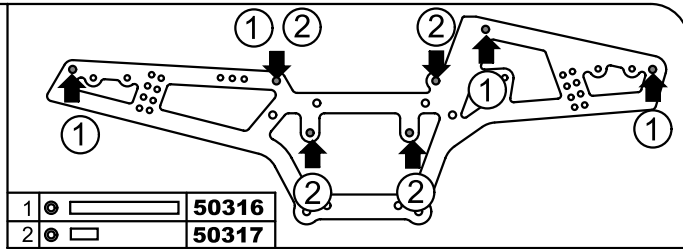

# STEP. 2

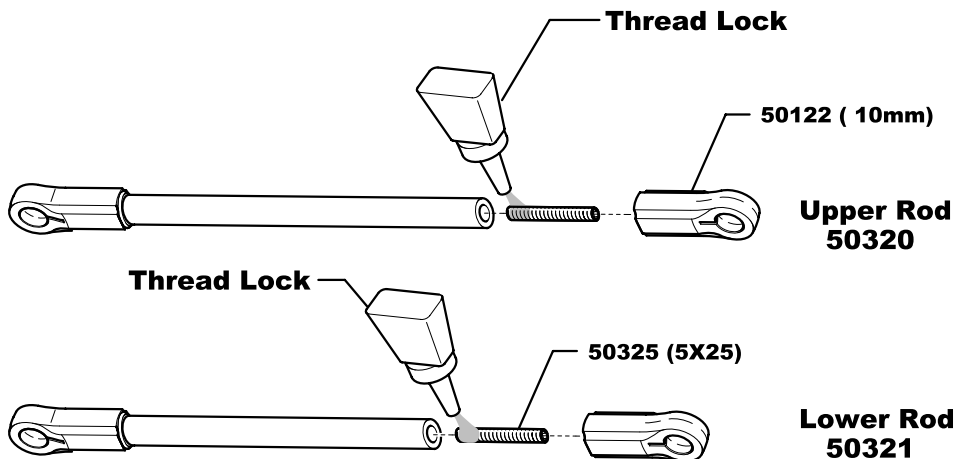

### STEP. 3

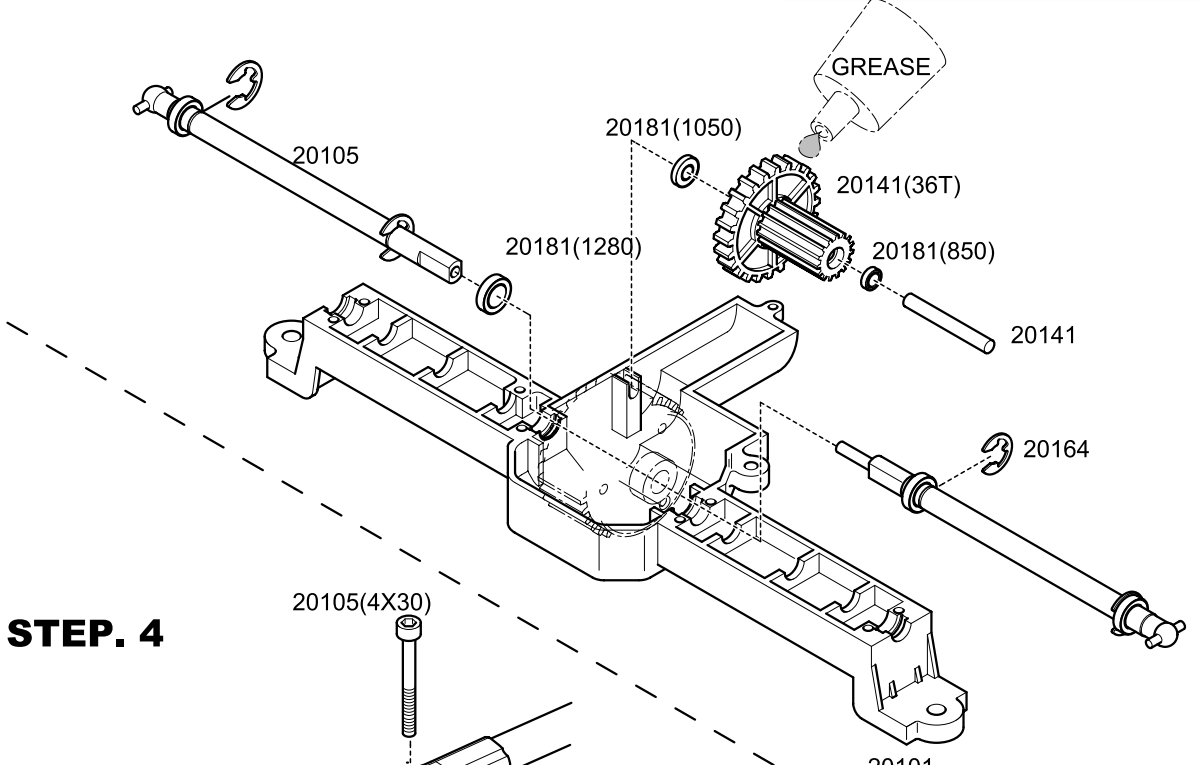
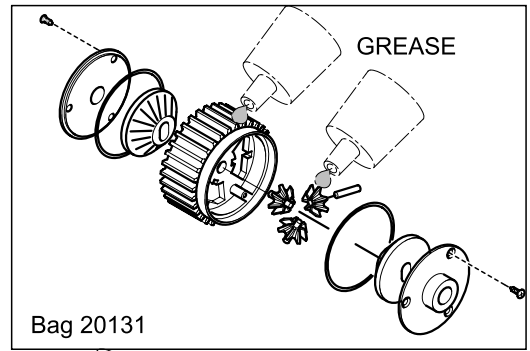

### STEP. 4

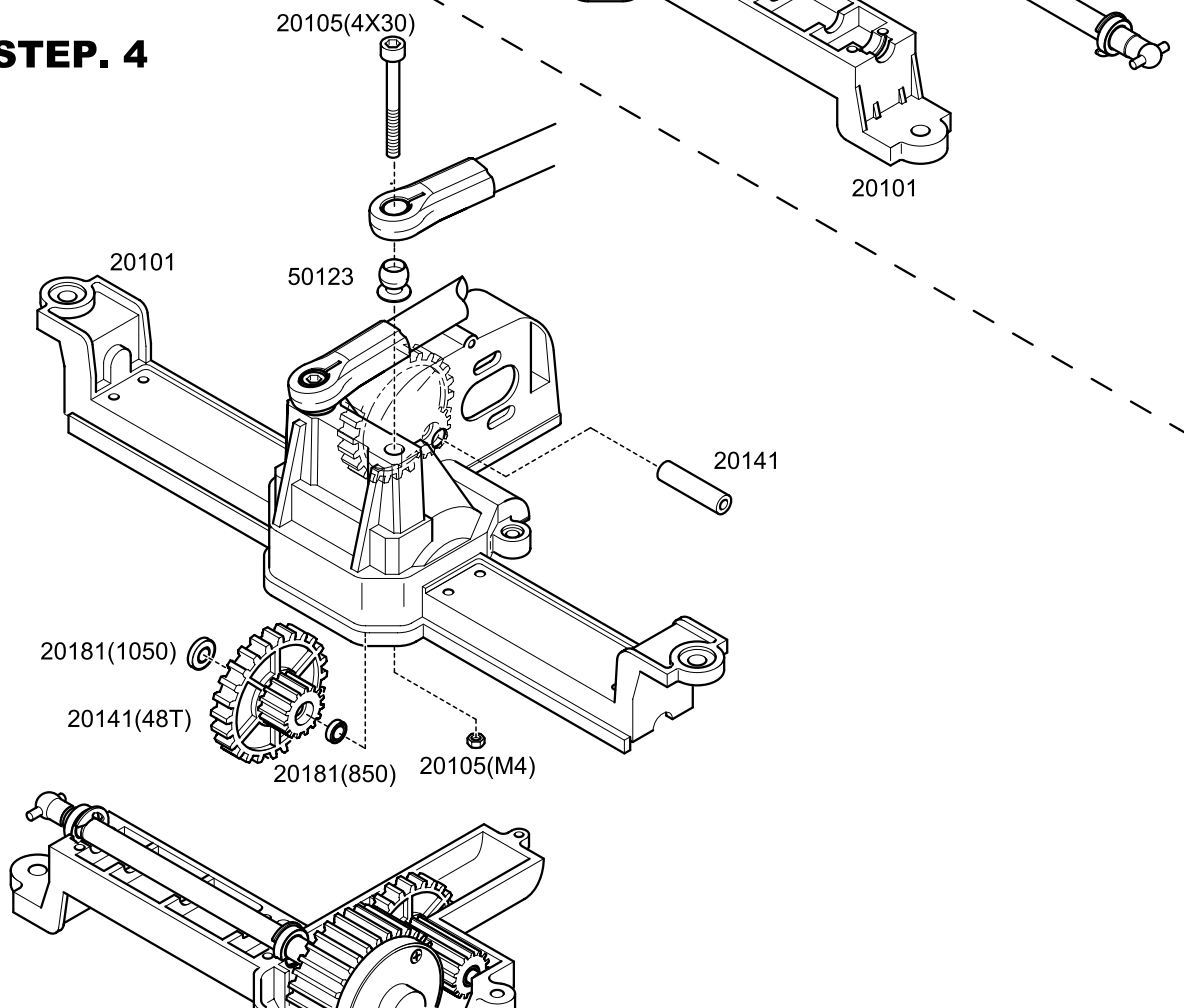

## STEP. 5

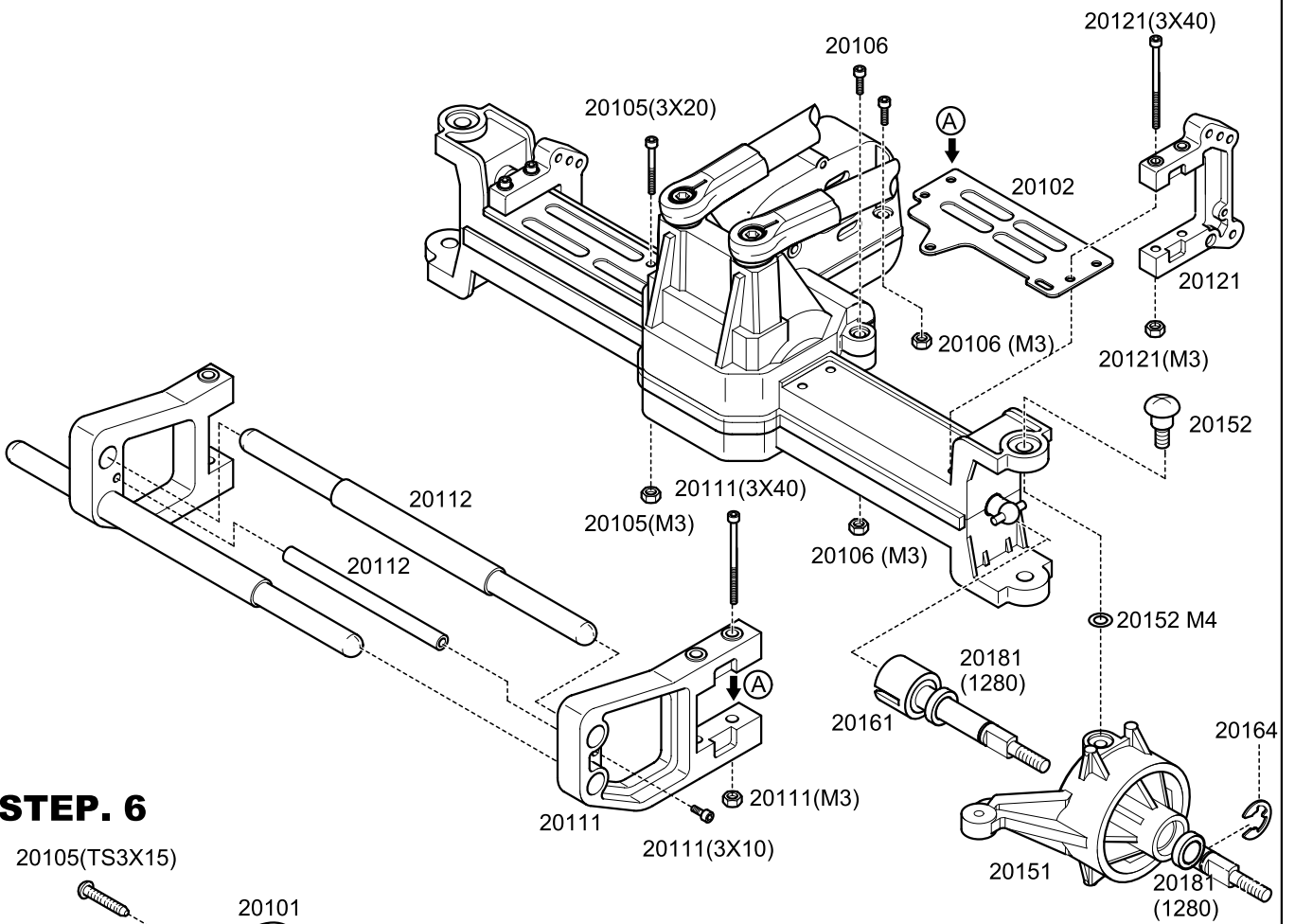

## STEP. 6

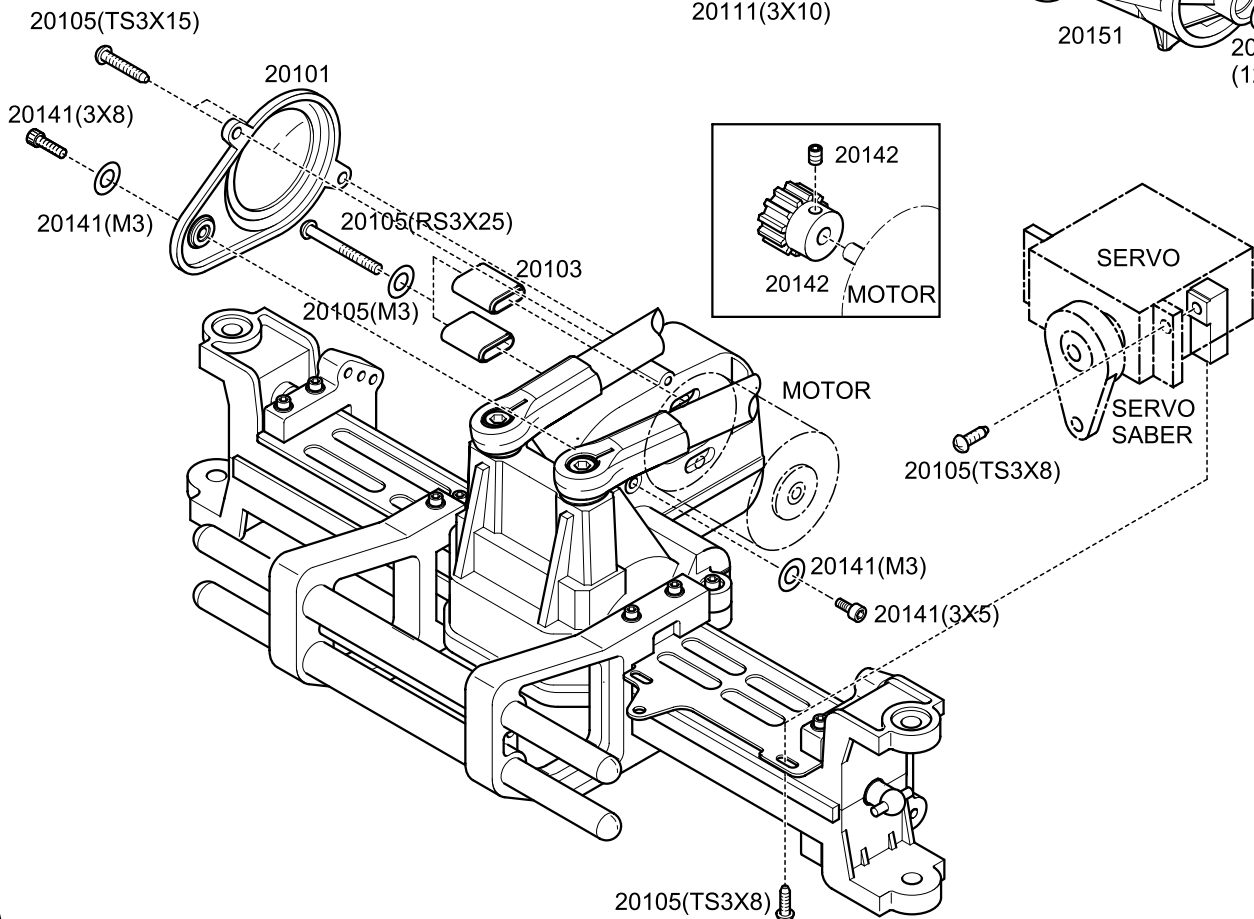

**STEP. 7**  
**front**

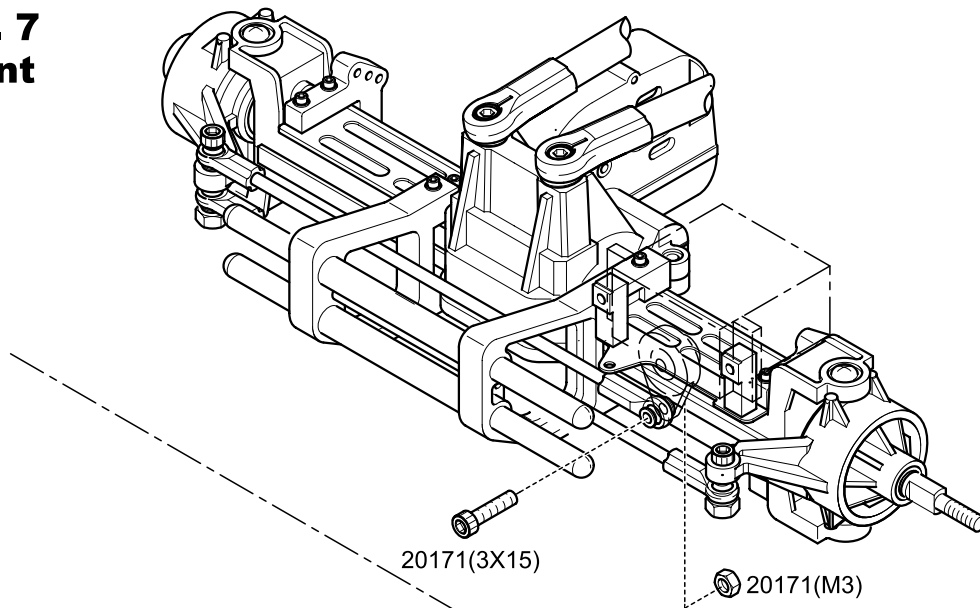

**STEP. 8**  
**rear**

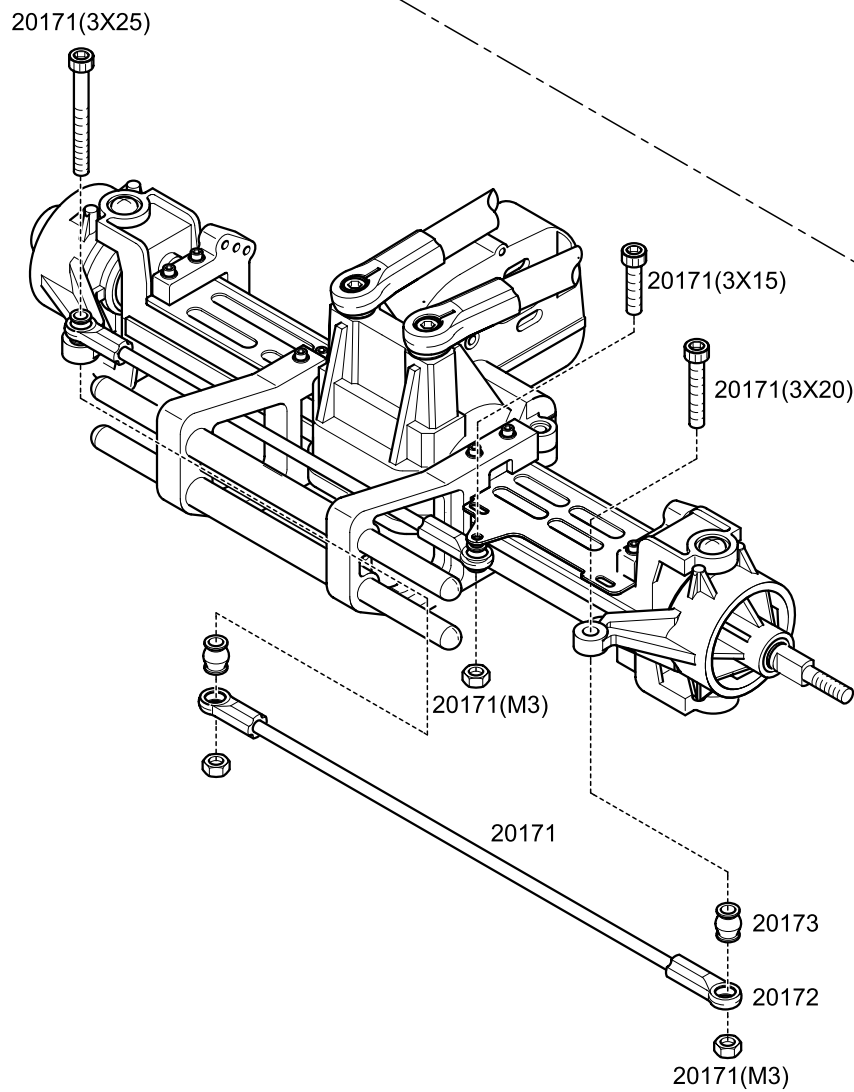



# STEP. 9

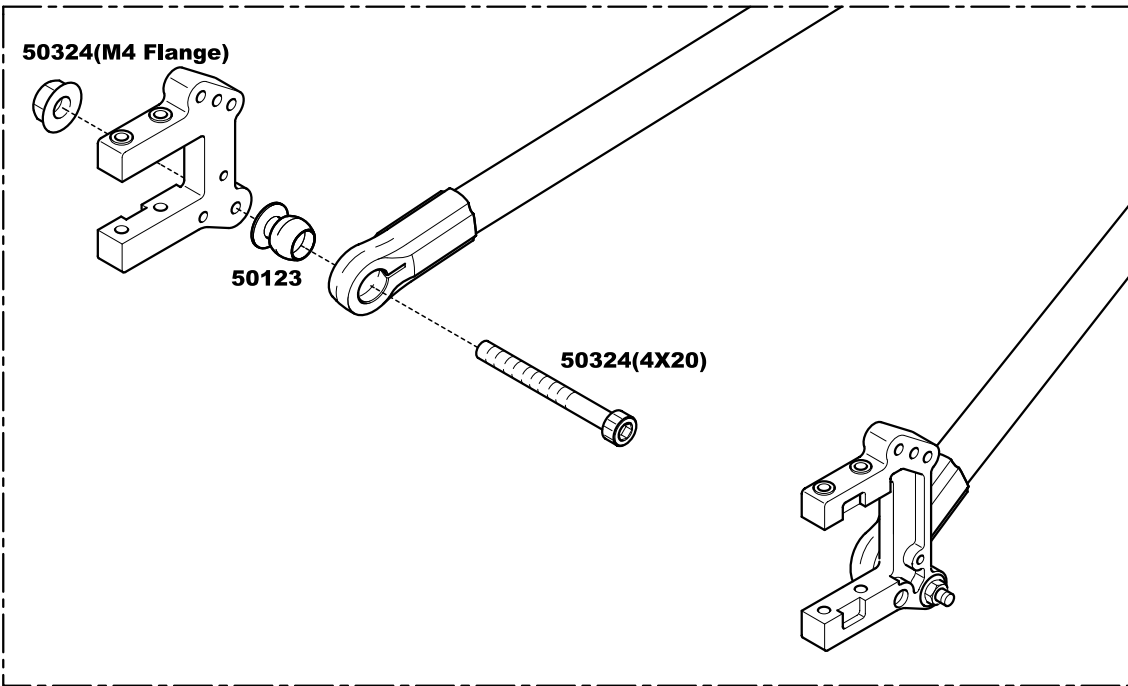
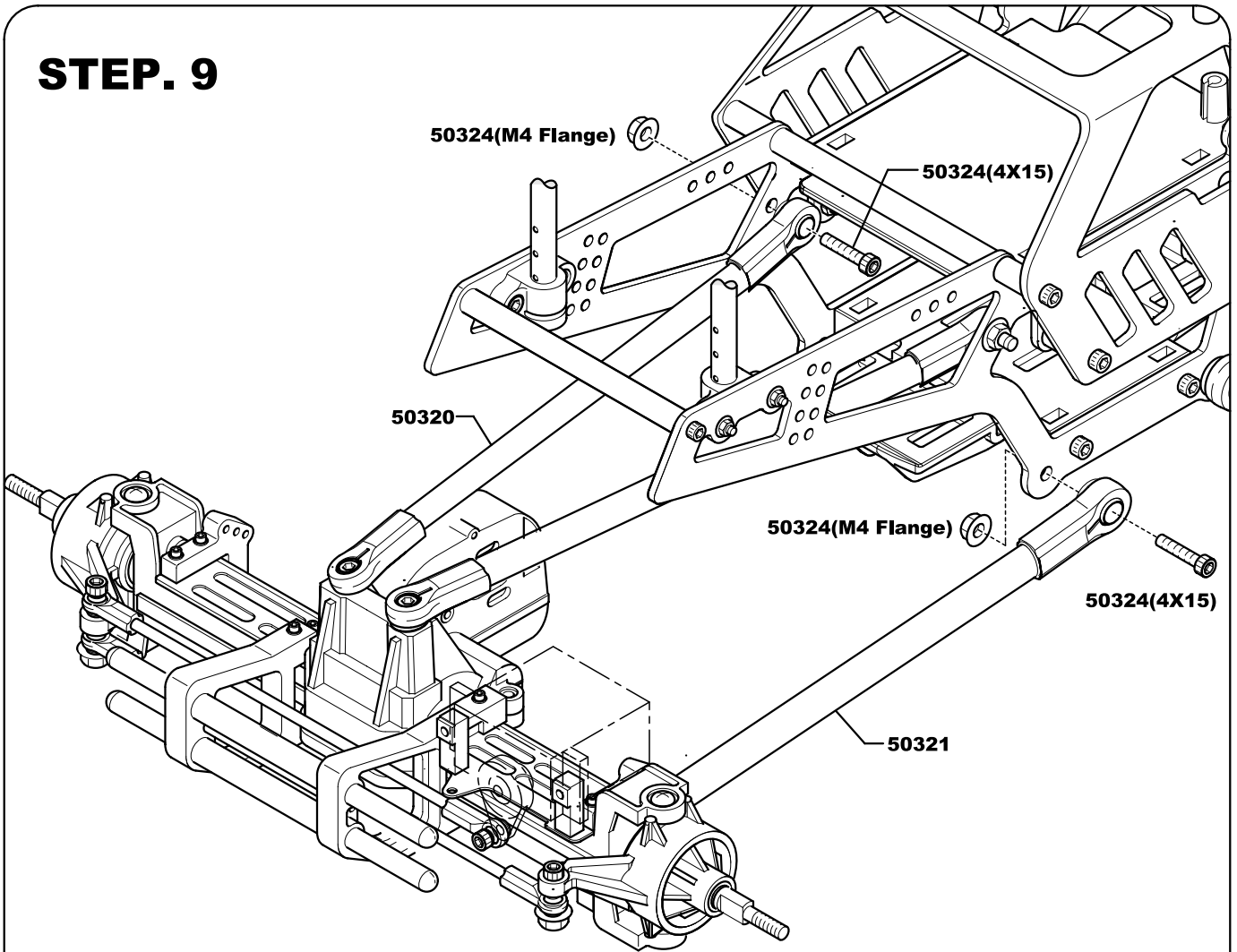

# STEP. 10

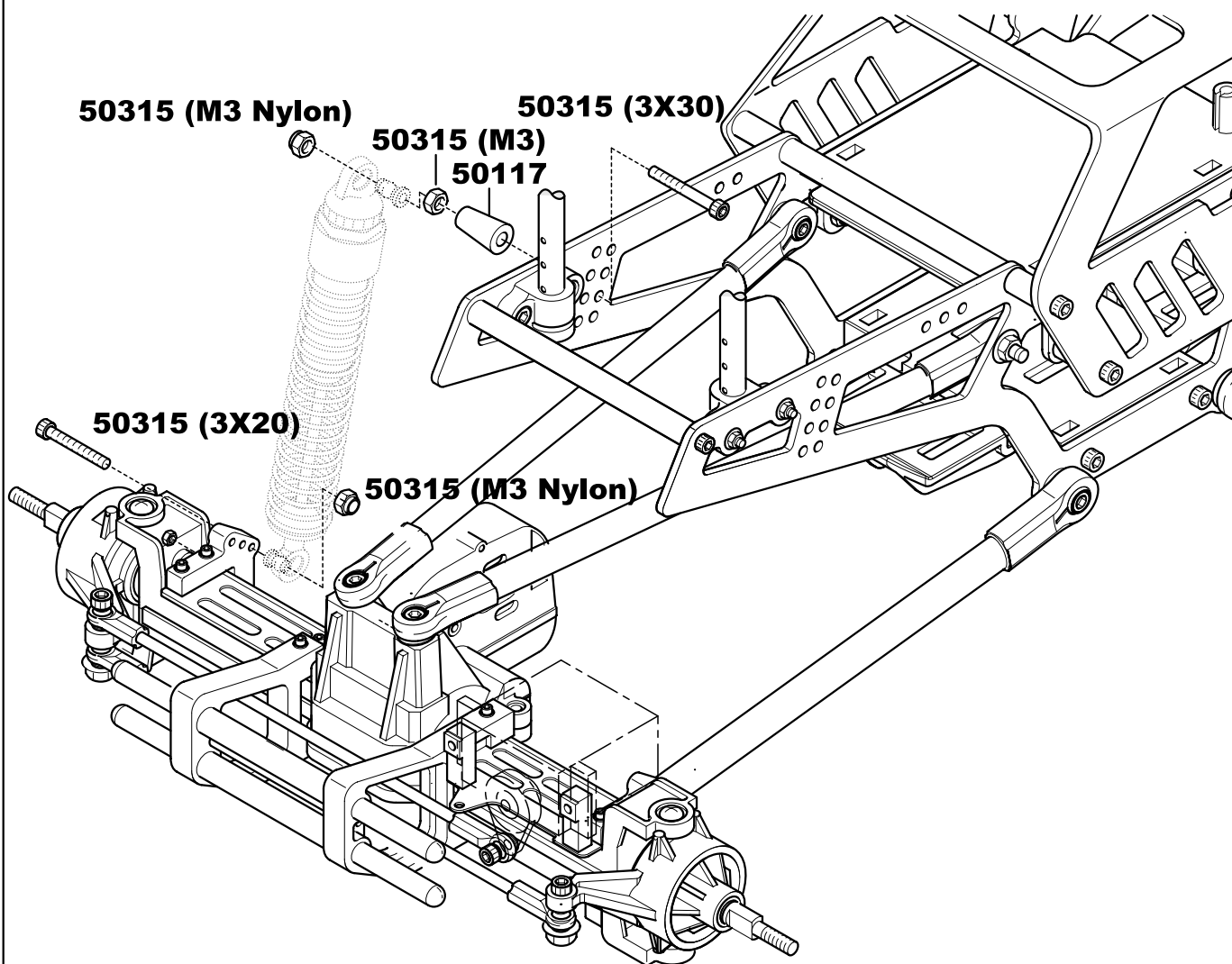

( MOVING FREE )	( O )	( X )

# STEP. 11

