

co-axial Easy control happy flying **LAMA V3**

HELICOPTER SYSTEM

2.4G

2.4GHz 展频传输技术
2.4GHz SPREAD SPECTRUM TECHNOLOGY
2.4GHz 远距离遥控超稳定性 频点之间互不干扰。
2.4GHz Remote control system with high stability
and non frequency interfering



Specification

- (1) Main rotor diameter: 340mm;
- (2) Weight: 215g;
- (3) Length: 360mm;
- (4) Power system: 180 motor*2;
- (5) KIT/ARF/RTF: RTF;
- (6) Transmitter: 4 CH 2.4GHz system (including training switch and simulator port)
- (7) Mix controller: 4in1 controller (W/gyro, mixer, ESC, receiver);
- (8) Servo: Digital servos 7.5g, Torque: ≥ 1.0 kg.CM, Speed: 0.1S/60°

Product description:

The design of the Lama V3 adopts a co-axial and counter-rotating system which makes it most suitable for indoor flight. Its characteristics are: easy, controllable flying, simple operation and quick re-charging. The 4in1 mixer controls all the main functions including: electric speed controller, gyro and receiver, which allows for convenient adjustment and maintenance of the helicopter. Two superior 180 motors and one 7.4V Lithium battery offer powerful performance and long flight times. The weighted fly-bar and improved tail system also enhance the stability and balance of the helicopter in flight, making it possible for beginners to master the basic flight skills in a very short time. You will be able not only to hover but to control the helicopter in all directions. Make slow and fast turns to test your skills and place the helicopter at chosen points around the room. Having mastered taking-off and landing, you will find endless ways to enjoy your Lama V3!

The new 2.4G remote control system adopts Advanced Spread Spectrum Technology and digital FSK (frequency shift key) coding technology. This combined with two digital servos, ensures a rapid response, precise control and nimbler movement. With this system, several flyers can operate simultaneously within the same immediate area offering a safe and relaxed flying experience.

实际配备因版本不同而有所差别，请以实际配备为准。
Note: Different versions, different equipment!

E-SKY[®]



产品介绍:

Lama v3 设计采用共轴反转双桨系统,适宜在室内飞行,设计特点是:容易飞行、简单操作,打开包装只要进行简单的充电就可以进行飞行。四合一控制器 集合了(混控、电子调速器、陀螺仪、接收机)的功能,方便了直升机的调整和维修,摆锤的设计提高了直升机飞行的稳定性和平衡性,可以使初学者在短时间内学会飞行掌握飞行的基本技巧。改良的机架更加的牢固,可爱的尾旋翼可以在飞行中迎着气流自由旋转。使用两颗优质的 180 马达和 7.4 V 的锂电池使直升机的飞行时间更加长久,飞行动力也更加的充沛,可以轻松自如的在空中完成快速自转、悬停、盘旋等各种航线飞行,在空中的飞行犹如空中漫步,让您尽情的享受飞行带来的乐趣!

遥控系统采用全新2.4G 智能化展频传输技术与数字化跳频技术,搭配两颗数字伺服器,遥控操作反应速度更快,动作更加灵敏、准确;可多人同时同地操作,使您自由尽情的飞行。

包装内发射机及充电配备 Transmitter and charging equipments in t



4 CH 2.4GHz system



000512
电源适配器
Power supply



000152
充电器 Charger



主旋翼 Plastic blade



000173
电池 Battery

直升机起飞步骤 The operation guide before fly



1. 电池充电
Charging battery



2. 安装电池
Loading battery



3. 打开发射机
Turn on the transmitter



4. 连接直升机电源
Connecting the battery



5. 四合一上红色对码灯闪烁后恒亮, 对码成功, 另一面信号指示灯恒亮绿灯, 显示待飞. The red calibration indicator light on the 4 IN 1 mix controller box (on the helicopter) will blink for a few seconds then show a constant red light, this indicates that the calibration is successful. When the green indicator light (on the other side), displays a constant light, you are ready to fly.

主旋翼攻角的调整 (Main blade angle of attack adjustment):

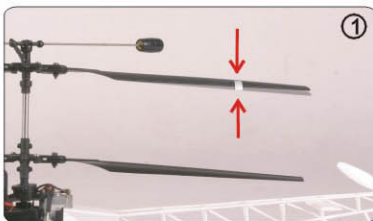

(1) 主旋翼旋转不在同一平面
Main blades don't rotate in one plane.



(2) 主旋翼攻角调整方法
Adjustment way to angle of attack of main blades.



(3) 主旋翼旋转在同一平面
Main blades rotate in one plane.

自备工具 Facilities self-contained



尖嘴钳
Long nosed pliers



六角螺丝刀
Hexangular Screwdriver



十字螺丝刀
Cross Screwdriver

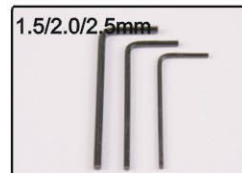

"L"型六角螺丝刀
"L" Screwdriver



剪刀 Scissors

LAMA 升级件

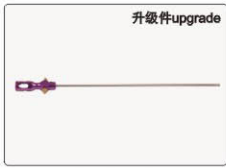

001100
中心座组
Central hub and shaft
set(upper)

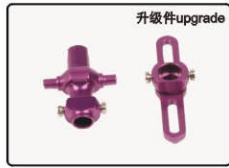

001101
下中心座组
Bottom Central holder Set



001102
倾斜盘组
Swashplate set



001103
夹片组
Mainblade grip set



完成
Completed.

机体局部设备示意图: Construction schematic diagram to inner equipments

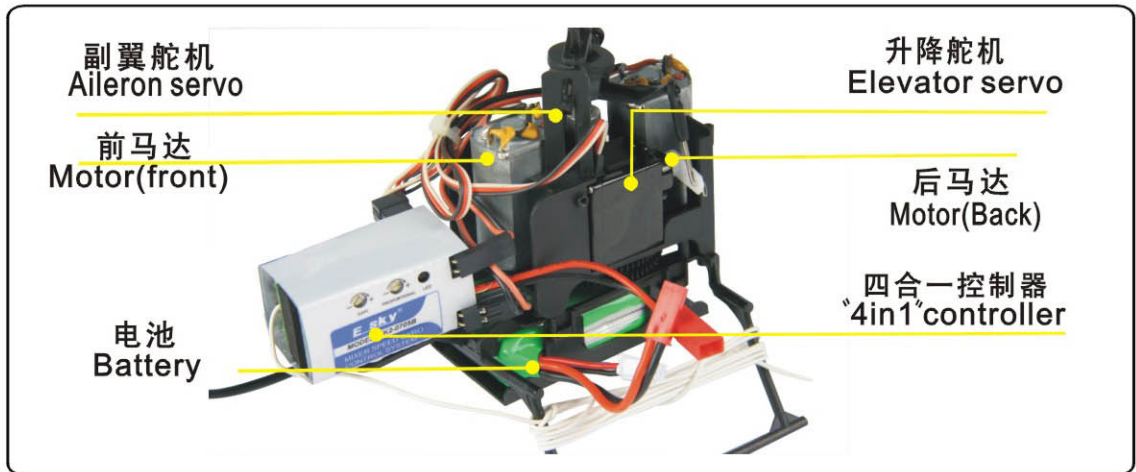

内部设备结构示意图 Connection schematic diagram to inner equipments

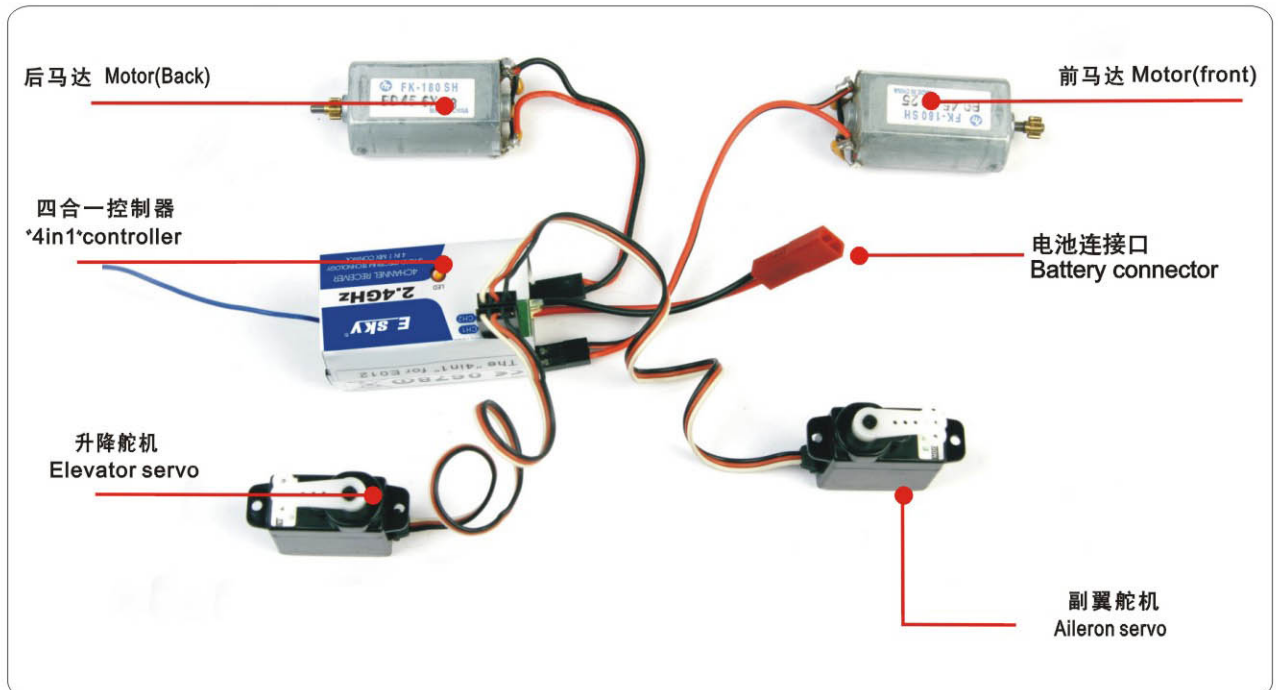

组件彩图 Spare parts picture

000283

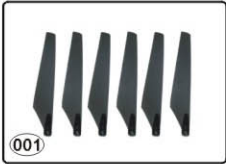

主旋翼A
Plastic blade A

000284

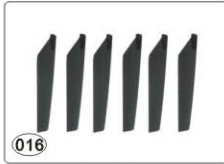

主旋翼B
Plastic blade B

000285



稳定锤
Stabilizer set

000286



主旋头A
Inner shatfA

000878



四合一
2.4G 4in1 Controller

000287



主齿轮总成 B
Gear & shaft set B

000288

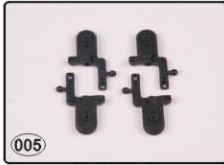

旋转夹头
Main blade grip set

000289



主旋头B
Inner shatfB

000290



倾斜外盘
Swashplate set

000155



8 g 数字伺服器
Digital servos 8g

000291



机架 Main frame

000292



齿轮和轴设置A
Gear & shaft set A

000294

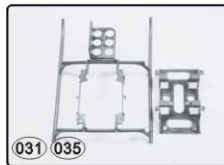

滑撬和电池架
Landing skid

000297



机头仓 Cabin

000513



适配器
Switching adapter

000299



轴承固定套
Bearing set collar

000300



拉杆 Bell link

000159



180前马达180# Motor

000160

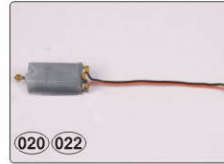

180后马达180# Motor

000513



发射机 Transmitter
4 CH 2.4GHz system

000308



4*8*3轴承 Bearing4*8*3

000200



2*6*3轴承
Bearing2*6*3

000204



固定工具
Mounting accys & wrech

000173



锂电 Li-polymer
battery 7.4V800mAh

000152



充电器 Charger

000302



五金配件
Hardware set

000307

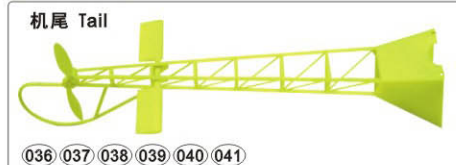

机尾 Tail

注意：配件图中的编号为分解图中对应的零部件的编号。
Note: Please find Item No. of the spare parts pictures in the exploded view.

机体爆炸图 Exploded view

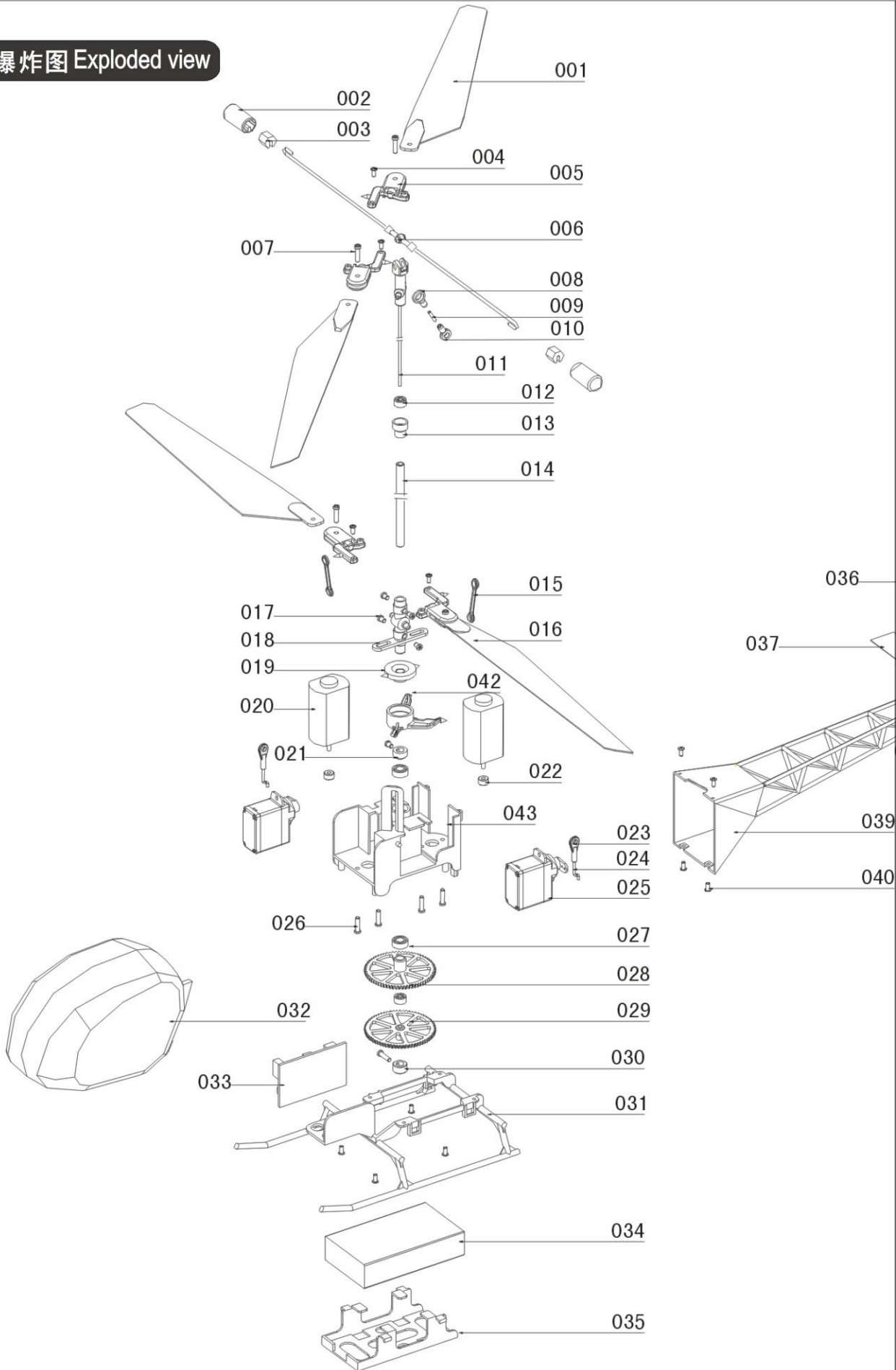

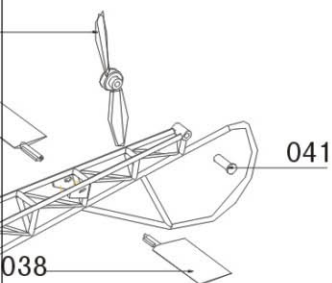

序号 Item Number	Description 名称	用量 Qty need
001	Plastic blade A 主旋翼A	2
002	Stabilizing weight 稳定锤	2
003	Balance weight 配重块	2
004	Screw(TWB1.7*4)伞头十字螺丝	4
005	Main blade grip set主翼夹头	4
006	FlyBar 平衡翼杆	1
007	Screw(M2*8) 内六角螺丝	4
008	Control link A 单孔拉杆A	1
009	Threaded bar (M1.4*8) 无头螺杆	1
010	Control link B 单孔拉杆B	1
011	Inner shaft A 主旋转头A	1
012	Bearing 滚珠轴承(Ø2*Ø6*L3)	2
013	Bearing bracket 轴承架	1
014	Main Bearing B 轴承B (Ø4*101)	1
015	Two-hole link rod双孔连杆	2
016	Plastic blade B 主旋翼B	2
017	Screw(ISO2*2.5)圆头十字螺丝	5
018	Inner shaft B 主旋转头B	1
019	Inner swashplate 倾斜内盘	1
020	Motor 180 180主马达	2
021	Set collar 定位环 (8*4)	1
022	Main motor gear主马达齿轮	2
023	Push-rod head 拉杆头	2
024	Push-rod 拉杆A	2
025	Servo 伺服器	2
026	Screw(ISO2*4) 圆头十字螺丝	6
027	Bearing(Ø4*Ø8*L3)滚珠轴承	2
028	Main gear B 齿轮B	1
029	Main gear A 齿轮A	1
030	Gear fix collar 齿轮固定环 (8*4)	1
031	Landing skid 滑撬	1
032	Cabin 机头罩	1
033	^4in1^controller 四合一控制器	1
034	Battery 锂电池	1
035	Battery frame 电池架	1
036	Tail blade 尾旋翼	1
037	Right balance blade 右侧翼	1
038	Left balance blade 左侧翼	1
039	Tail frame 尾架	6
040	Screw(TPB 1.7*4)平头十字螺丝	8
041	Tail blade shaft 尾旋翼轴	1
042	Outer swashplate 倾斜外盘	1
043	Main frame 机架	1