

1/10 SCALE EP OFF-ROAD 2WD RACING BUGGY

ACADEMY

HOBBY MODEL KITS

GRIFFIN

NEO GRIFFIN



● Technical Data (NEO GRIFFIN)
 LENGTH(전장) : 380mm WIDTH(전폭) : 255mm
 HEIGHT(전고) : 168mm WHEEL BASE(휠베이스) : 280mm
 TREAD(F/R) 트레드(전/후) : 218/212mm
 TOE-IN(F/R) 토크인(전/후) : EXCHANGEABILITY 가변/0
 CASTER(F/R) 캐스터(전/후) : 30° / 3°
 WEIGHT 중량(배터리포함) : 1640g

CA142 #1565

INSTRUCTION MANUAL

설명서

PRO GRIFFIN



● Technical Data (GRIFFIN Pro)
 LENGTH(전장) : 380mm WIDTH(전폭) : 255mm
 HEIGHT(전고) : 168mm WHEEL BASE(휠베이스) : 267mm
 TREAD(F/R) 트레드(전/후) : 218/212mm
 TOE-IN(F/R) 토크인(전/후) : EXCHANGEABILITY 가변/2°
 CASTER(F/R) 캐스터(전/후) : 30° / 3°
 WEIGHT 중량(배터리포함) : 1570g

CA148 #1566

Cut away 잘라낸다

Use allen key, ⊕wrench.
 L자 또는 ⊕자렌치를 사용하여 조립한다.

Optional parts 선택한다



3 Repeat operation 수 만큼 조립한다

Make hole 구멍을 뚫어준다.

Apply grease to the place. 그리스를 바른다

Apply instant glue to the place. 순간접착제를 바른다

※ Do not use excessive force when tightening the tapping screws and bolts.
 볼트 및 비스를 질 때 너무 무리하게 힘을 가하지 않는다.

■부품을 조립하기전에

- 구입 후 조립하기 전에는 반드시 부품도와 대조, 확인하고 불량 부품이나 부족한 부품이 있을 경우에는 구입한 직매점이나 A/S센터를 이용하시기 바랍니다.
- 조립을 시작한 후에는 반품이나 교환을 사절합니다. ● 작은 비스, 너트 등은 모양이 비슷하므로 설명서를 잘 읽어 본 후 조립한다.
- 송수신기 및 서어보에 물이 들어갔을 경우 보증수리가 되지 않으니 취급에 주의한다. ● 한 가지씩 조립을 확실하게 해나가는 것이 고장을 막고 제성능을 충분히 발휘하는 좋은 R/C모델이 된다.

■ RADIO CONTROL UNIT

2채널 송수신기 세트

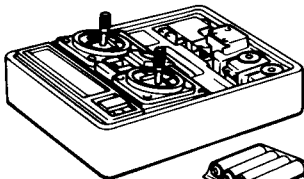

2 channel Radio Control unit
2채널 송수신기 세트

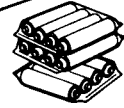

Battery
송수신기용 배터리
(1.5V 12EA)

This kit is designed for a 2 channel 2 servo digital proportional type of radio control system.

Almost any 2 channel radio can be used. A unit can be used in other model.

본 키트에는 2채널 송수신기 세트를 이용한다. 어느 회사의 것이든 무방하며, 일단 1세트가 준비되면 여러가지 R/C모형에 응용하여 사용할 수 있다.

■ POLYCARBONATE PAINT

색칠에 필요한 재료

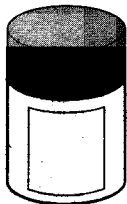

Polycarbonate paint
포리카보네이트 스프레이

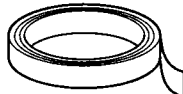

Masking tape
마스킹테이프

■ Ni-Cd BATTERY

7.2V 충전배터리

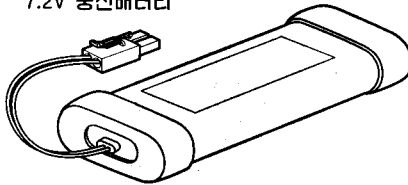

It can be recharged more than 300times.
니카드 배터리라고도 하며 충전하여 계속 사용(300회 정도) 할 수 있는 전지를 말한다.

■ CHARGER for Ni-Cd Battery

배터리 전용 충전기

■ CHARGER for Ni-Cd Battery

배터리 전용 충전기

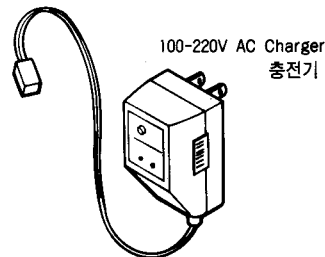

100-220V AC Charger
충전기

Academy NI-Cd battery is high effectiveness and can be recharged more than 300 times.

(100-220V AC Charger)

충전 배터리를 충전하는 것으로 가정용 100V~220V를 사용해서 15시간 정도 충전하는 것을 말한다.

■ TOOLS

조립에 필요한 공구

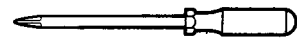

⊕ Screwdriver 드라이버

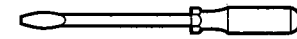

⊖ Screwdriver 드라이버

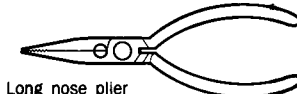

Long nose plier
라디오벤치



Nipper 니퍼

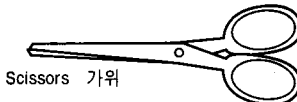

Scissors 가위

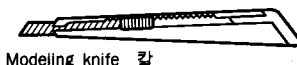

Modeling knife 칼

■ 접착제

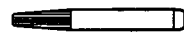

Instant cement
순간접착제

■ RC EQUIPMENT

송수신기의 동작시형

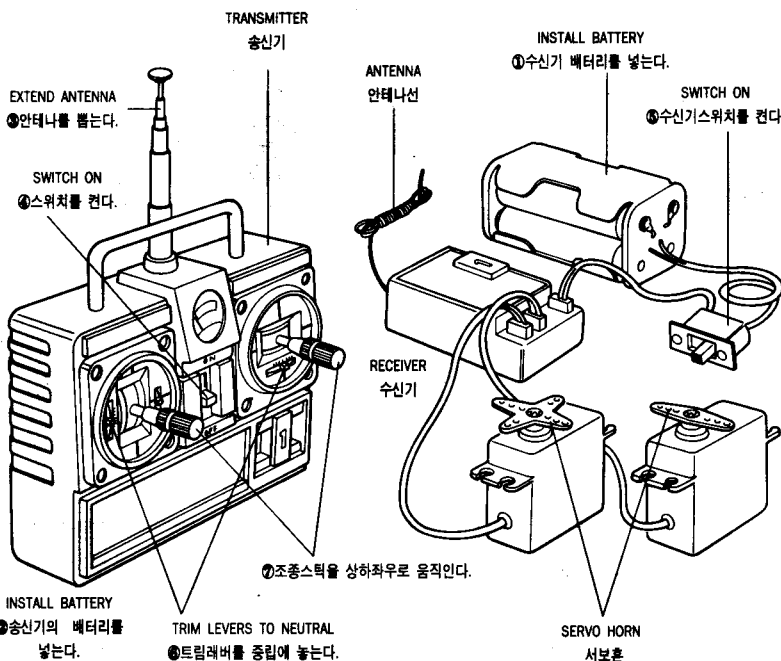

The digital proportional system comprises a transmitter, receiver, servos, etc.

- Transmitter - Servos as a control box. Stick movements are transformed into radio wave signals which are transmitted through the antenna.
- Receiver - Receives signal from the transmitter.
- Servos - Servo transforms signals received by the receiver into mechanical movements and actuates the control portion of the car.
- Trim Lever - Trim Lever is used to some change the direction of the front wheel or to speed control.
- Level Meter - Level Meter shows that batteries for the transmitter are playing out.
- Servo Horn - Servo Horn joints servo to the control portion of the car.

2채널 송수신기 세트는 송신기와 수신기, 서어보 및 배터리케이스로 구성되어 있다.

- 송신기 - 조종하는 콘트를 박스로서 모터의 회전, 키의 좌우 움직임을 안테나를 거쳐 전파로 송신한다.
- 수신기 - 송신기로부터 전파를 받아서 서어보로 보낸다.
- 안테나 - 송신기의 안테나는 전파를 보내고 수신기의 안테나는 전파가 들어오는 중요한 것으로 최대한 길게 사용하는 것이 좋다.
- 트림레버 - 송신기의 트림레버는 서어보의 중립위치를 좌우로 조금씩 움직여 속도조절이나 키의 방향을 수정할 때 사용한다.
- 레벨미터 - 송신기의 전원이 소모된 정도를 나타내는 눈금으로 송수신기의 전원이 약할 경우 잘못된 동작을 하는 경우가 있으니 항상 주의한다.
- 서어보혼 - 서어보와 차의 콘트부분을 연결하는 것으로서 여러종류가 있으므로 사용 목적에 맞는 형태를 사용한다.

1 GR-K 2

Choose ④ ⑤ ⑥ according to the course condition.
(④-Hard course, ⑤-medium, ⑥-Soft course)

④⑤⑥은 코스에 따라 선택한다.

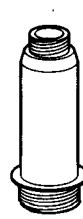
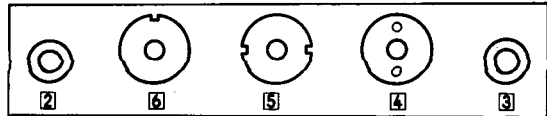

F/Oil damper body (Short)
전후오일댐퍼몸통(소) 2EA

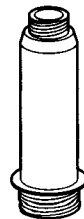

R/Oil damper body (Long)
후후오일댐퍼몸통(대) 2EA

Put E-ring using long nose plier as shown.
그림과 같이 라디오벤치를 사용하여 E-링을 끼워 넣는다.

Ø 2.5 E-Ring 8
E-링

Ø 2.5 E-Ring
E-링

Ø 2.5 E-Ring
E-링

2.6×10 P/H Tapping screw
동근머리비스

F/damper shaft (Short) 2
전후댐퍼샤프트

R/damper shaft (Long) 2
후후댐퍼샤프트

Spring guard
스프링가이드

GRIFIN PRO

C-Ring 4
C-링

GRIFIN PRO

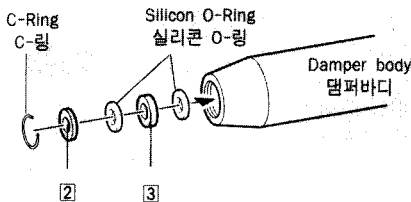

NEO GRIFFIN

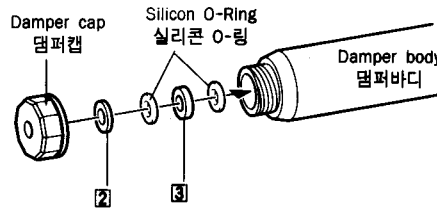

Use a pad to protect the damper shaft.
그림과 같이 볼패드 조립시 미끄러지지 않는 고무패드로 감싼 후 라디오 벤치로 잠고 조인다.

*주의- 댐퍼샤프트에 벤치 등으로 인한 상처(흠집)가 나면 댐퍼의 기능이 떨어진다.

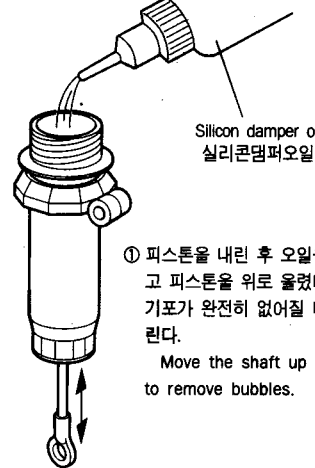
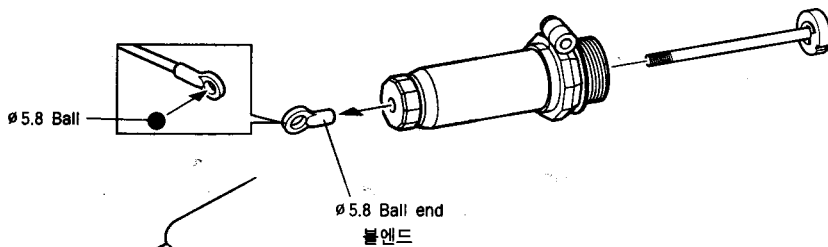

① 피스톤을 내린 후 오일을 가득 채우고 피스톤을 위로 올렸다 내린 후 기포가 완전히 없어질 때까지 기다린다.

Move the shaft up and down to remove bubbles.

② 실린더캡에 러버캡을 끼운다.
Put rubber cap in cylinder cap.

③ 댐퍼캡을 조여준다. Tighten damper cap.

④ 오일댐퍼캡을 조인 후 피스톤을 위, 아래로 움직여 본다. 밸런스가 안맞는 상태에서 장착을 하면 주행중 좌우의 움직임(Rolling)이 커져서 주행성능, 특히 코너링시 차가 불안정하게 되는 원인이 된다.

Tighten the oil damper cap and then move the piston up and down. If it is installed on unbalanced condition on both side, it'll have bigger rolling and especially, it causes an instability when cornering.

2.6×10 P/H Tapping Screw 4
동근머리비스

Ø 5.8 Ball 4
볼

Make each 2 sets for front & rear.
전후륜 각각 2 개씩 조립한다.



Spring guard
스프링가이드

F/Damper spring (Short)
전후댐퍼스프링(소)

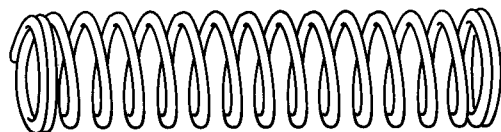
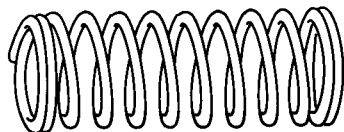
R/Damper spring (Long)
후후댐퍼스프링(대)



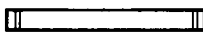

② GR-D

-  $\varnothing 4.3$ Pin ball 2
핀볼
-  $\varnothing 5.8$ Pin ball 2
핀볼
-  3x26 Hinge pin 2
힌지핀

-  $\varnothing 2$ E-Ring 4
E-링

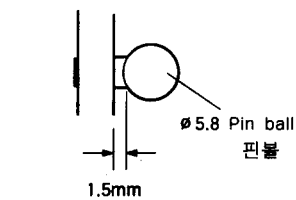
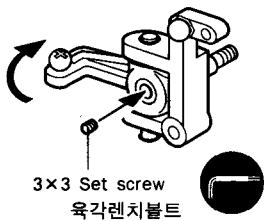
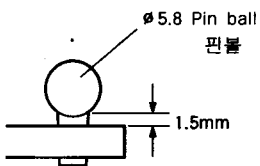
-  3x3 Set screw 2
육각볼트



-  $\varnothing 5.8$ Pin ball 2
핀볼

-  $\varnothing 2$ E-Ring 4
E-링

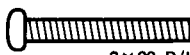
-  3x20 P/H Screw 2
볼트

-  3x10 F/H Screw 4
볼트

-  3x40 Hinge pin 2
힌지핀

- GRIFIN PRO**
 3x20 Cap screw 2
캡스크류

■ RIGHT 우측

■ LEFT 좌측

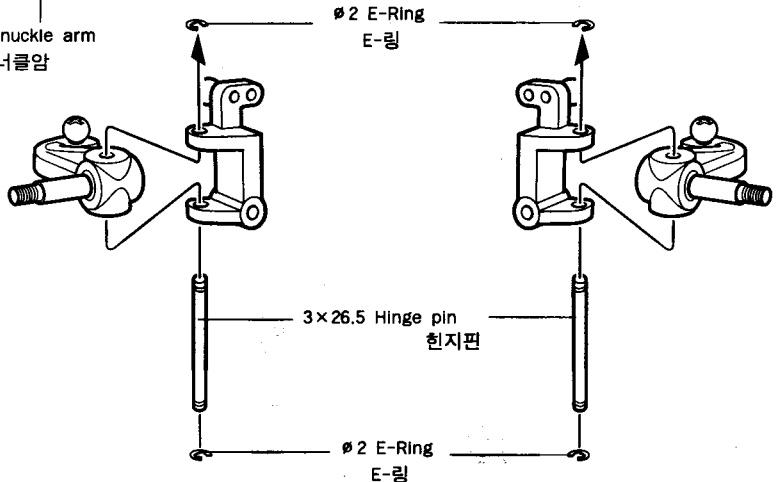
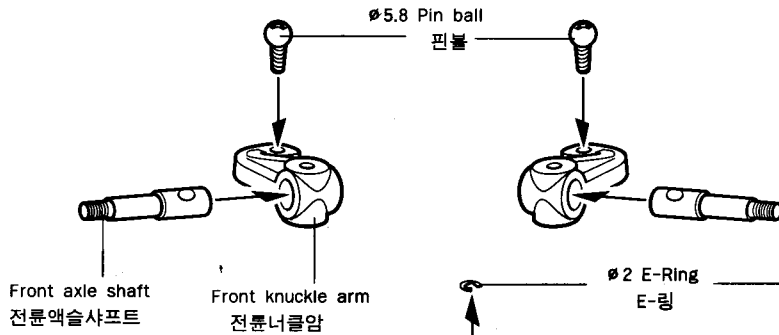
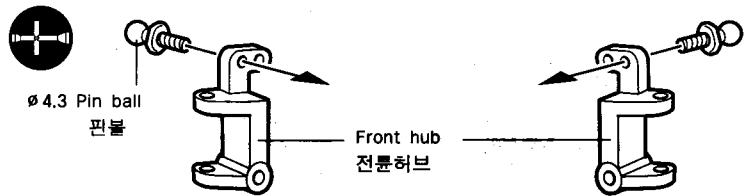

③ GR-D · F

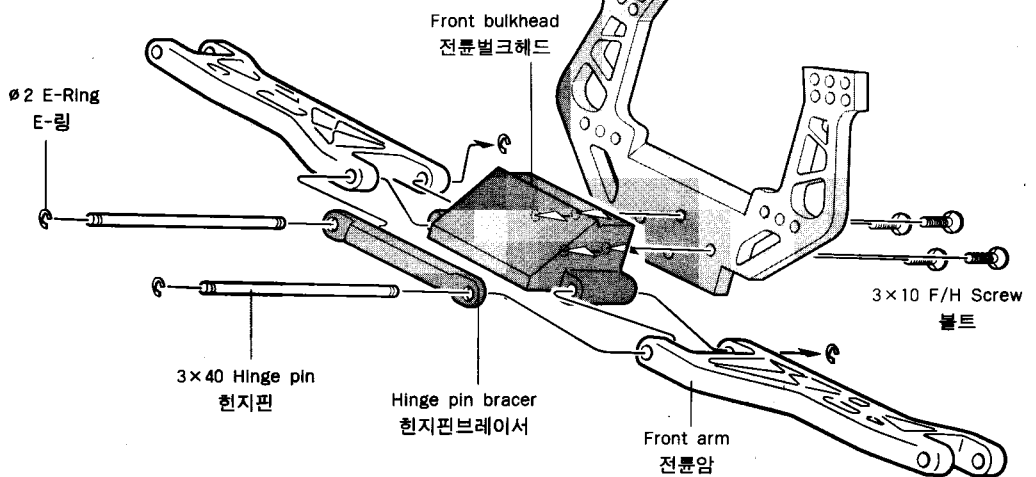
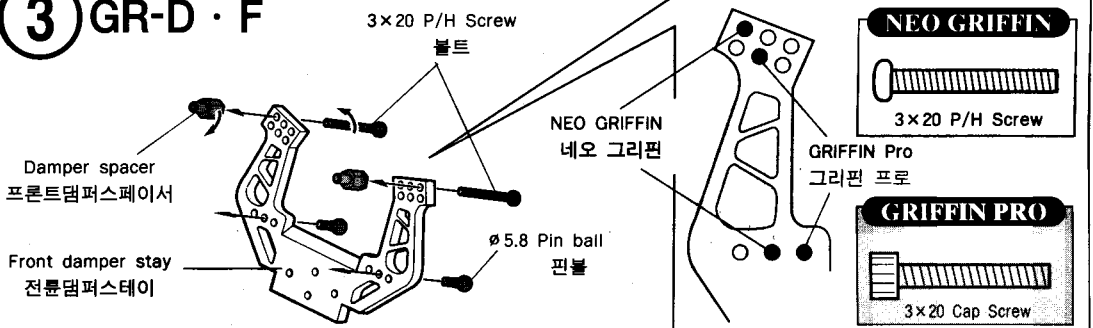

4 GR-D

2

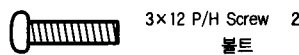
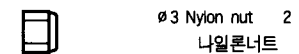
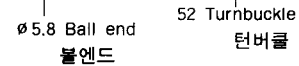
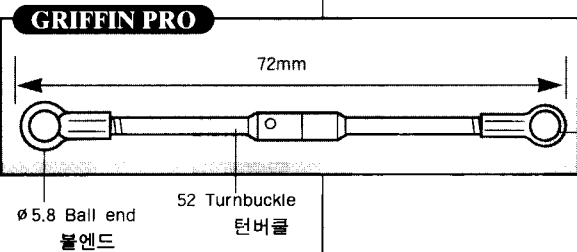
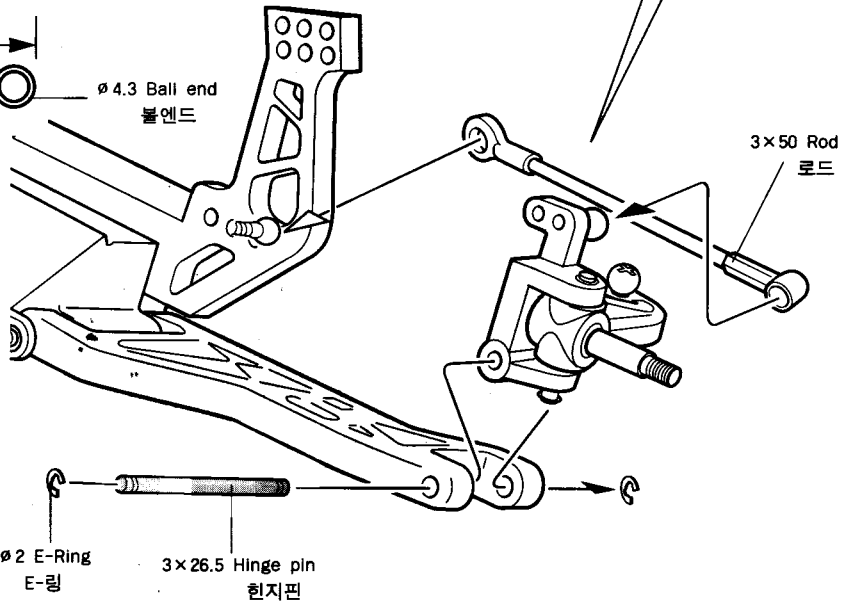
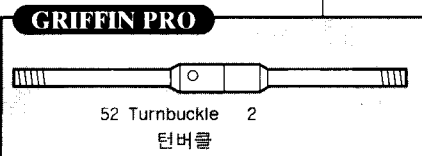
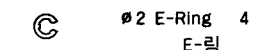
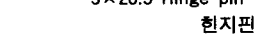
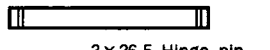
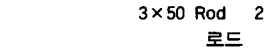
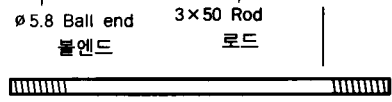
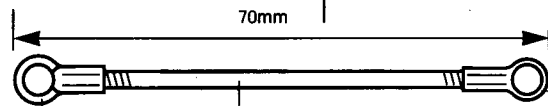
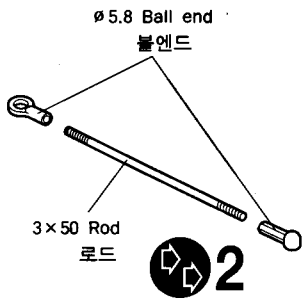

5 GR-K

2

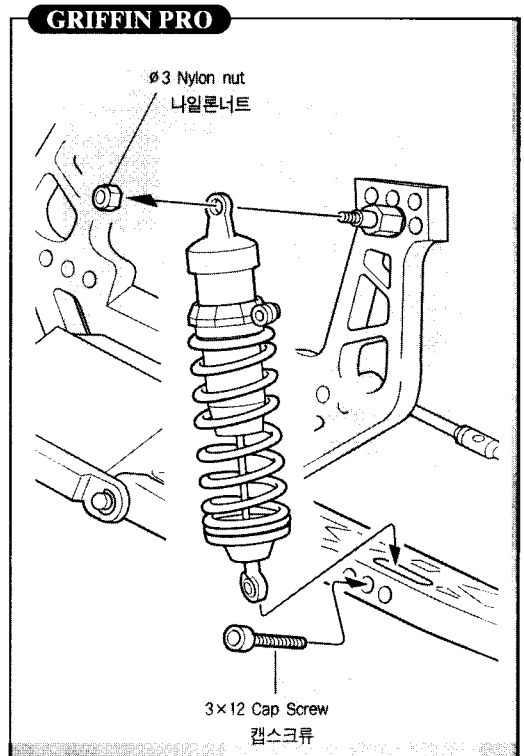
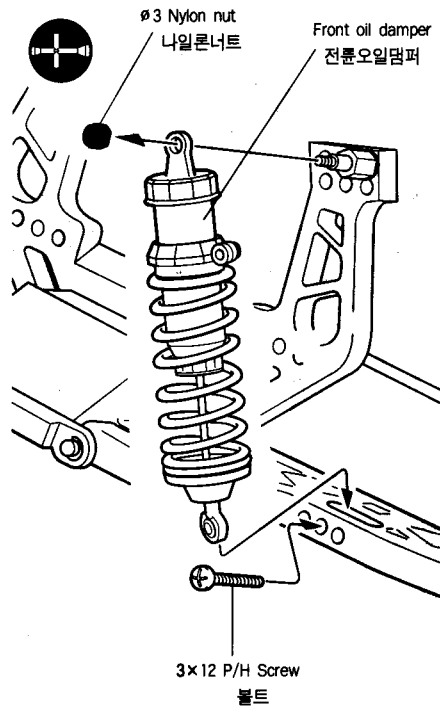

6 GR-A · E

7 GR-D

- 3×6 F/H Screw 4
볼트
- ø3 Nut 4
너트

- 3×10 F/H screw 4
볼트

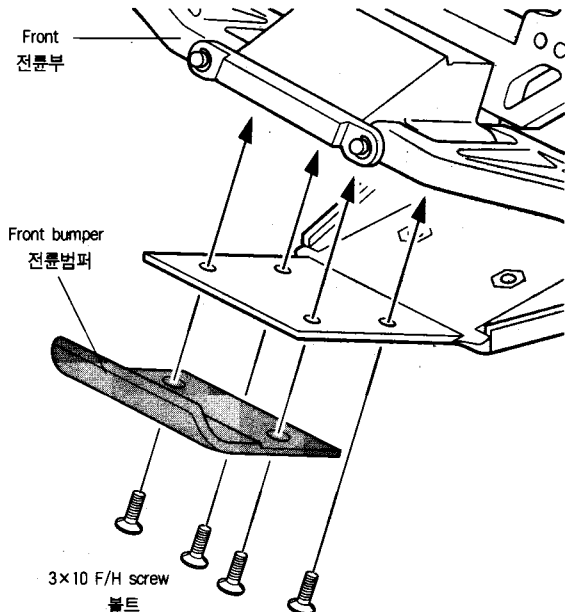
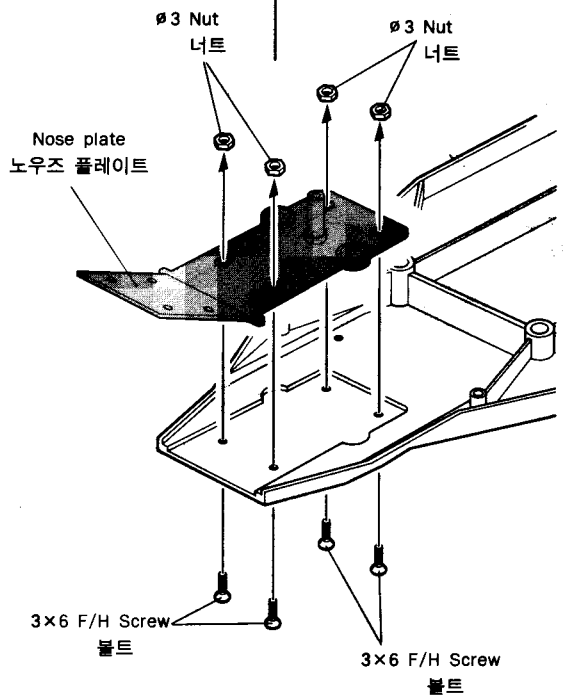

8 GR-E

- 3×65 Rod 2
로드
- 3×65 Turnbuckle 2
턴버클

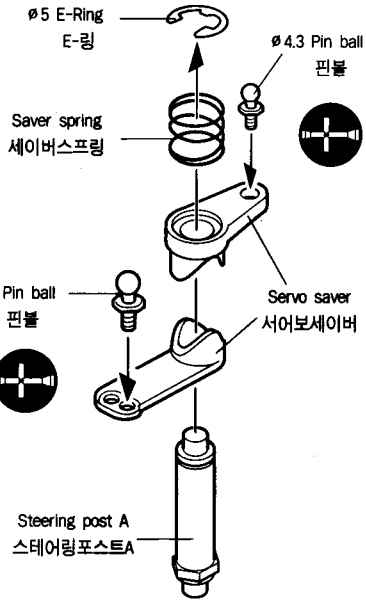
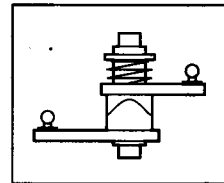
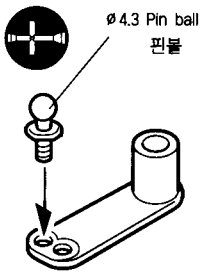

- ø4.3 Pin ball 3
핀볼
- ø5 E-Ring 1
E-링

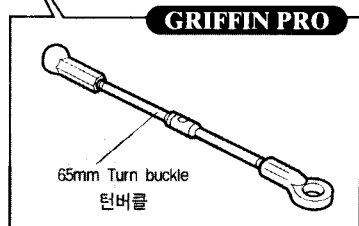
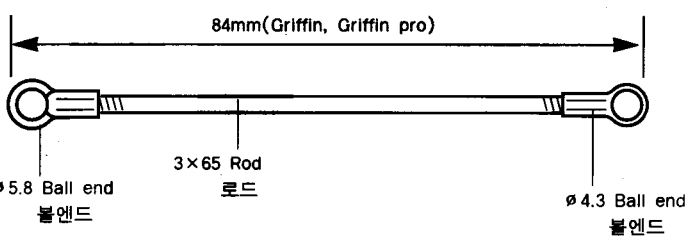
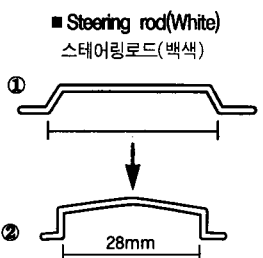
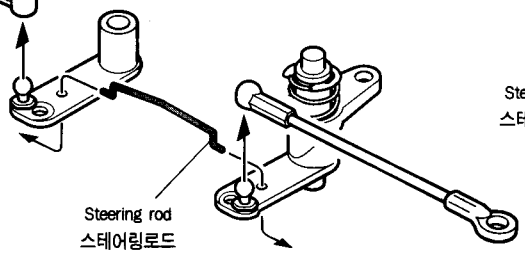
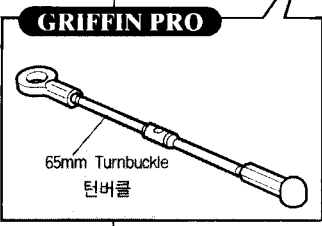

*Carefully bend ① refer to ②.
①의 형태를 ②의 형태로
구부려 사용한다.

9 GR-E

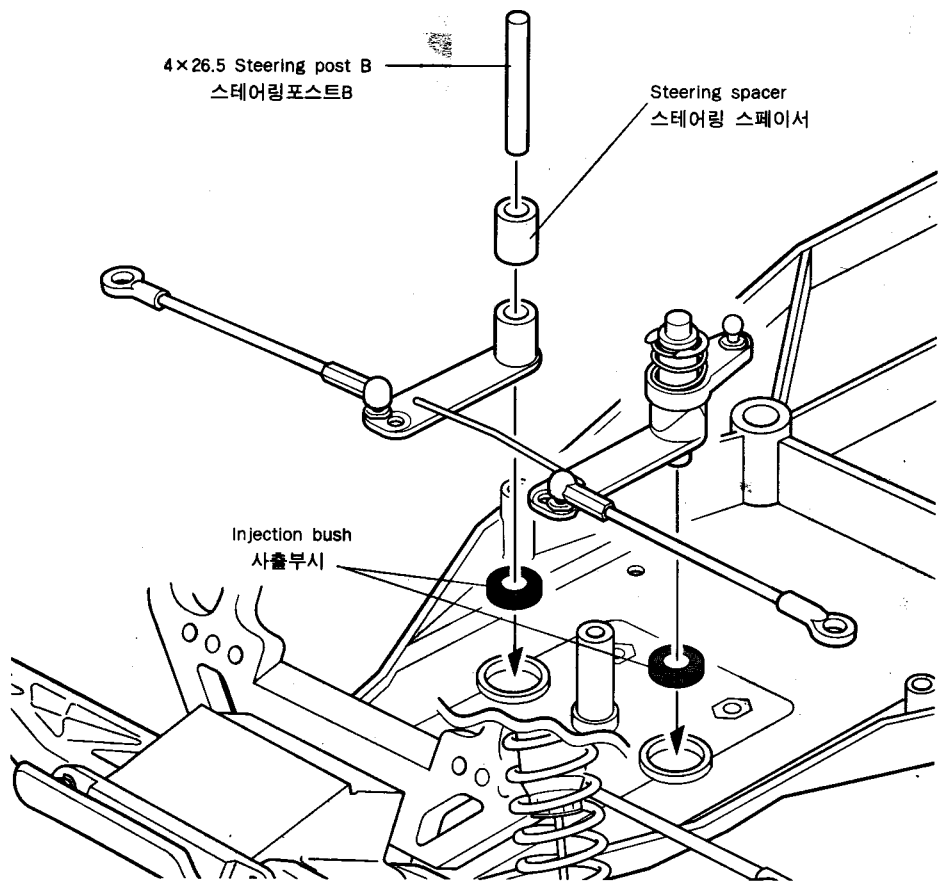
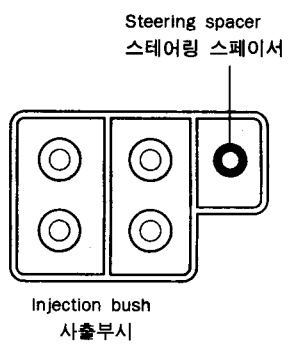
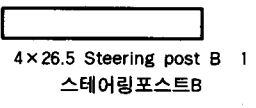

- ø4.3 Ball end
볼엔드
- 15mm Rod
로드
- ø4.3 Ball end
볼엔드
- 31mm
- 3x15 Rod 1
로드
- 3x8 P/H Tapping screw 2
비스
- 3x8 Washer 2
와셔
- 2.6x10 P/H Tapping screw 1
비스
- ø4.3 Pin ball 1
핀볼
- 3x10 F/H screw 2
볼트

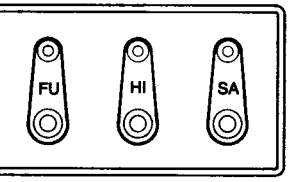

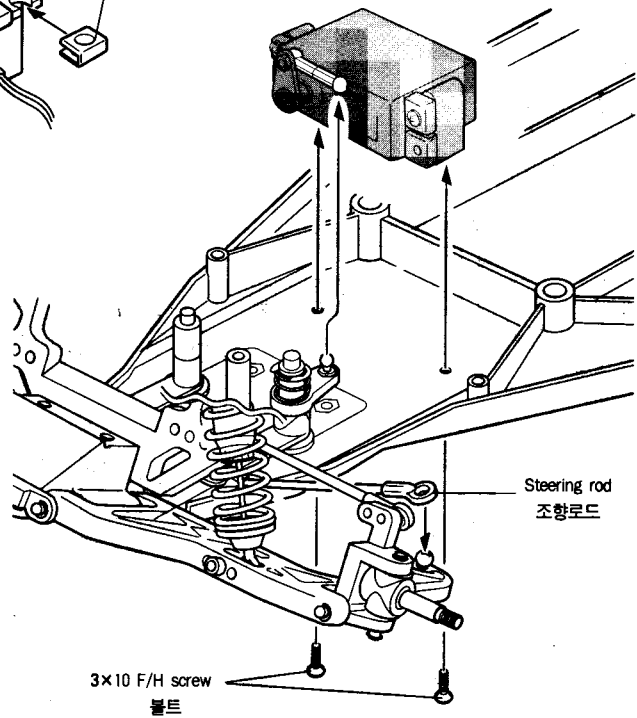
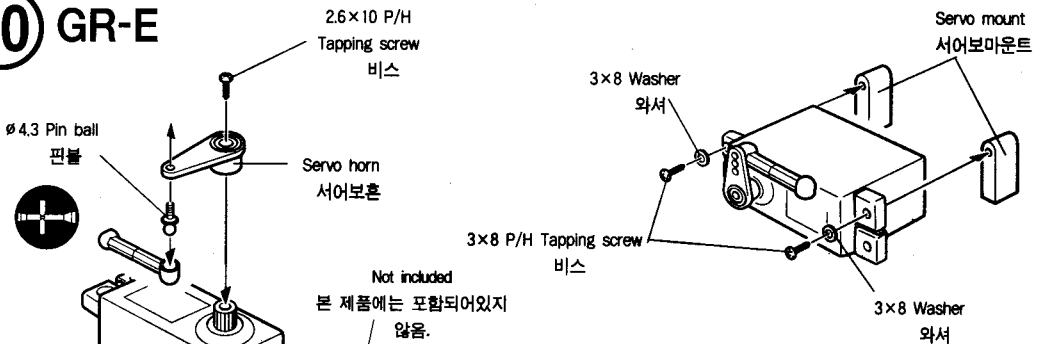

10 GR-E



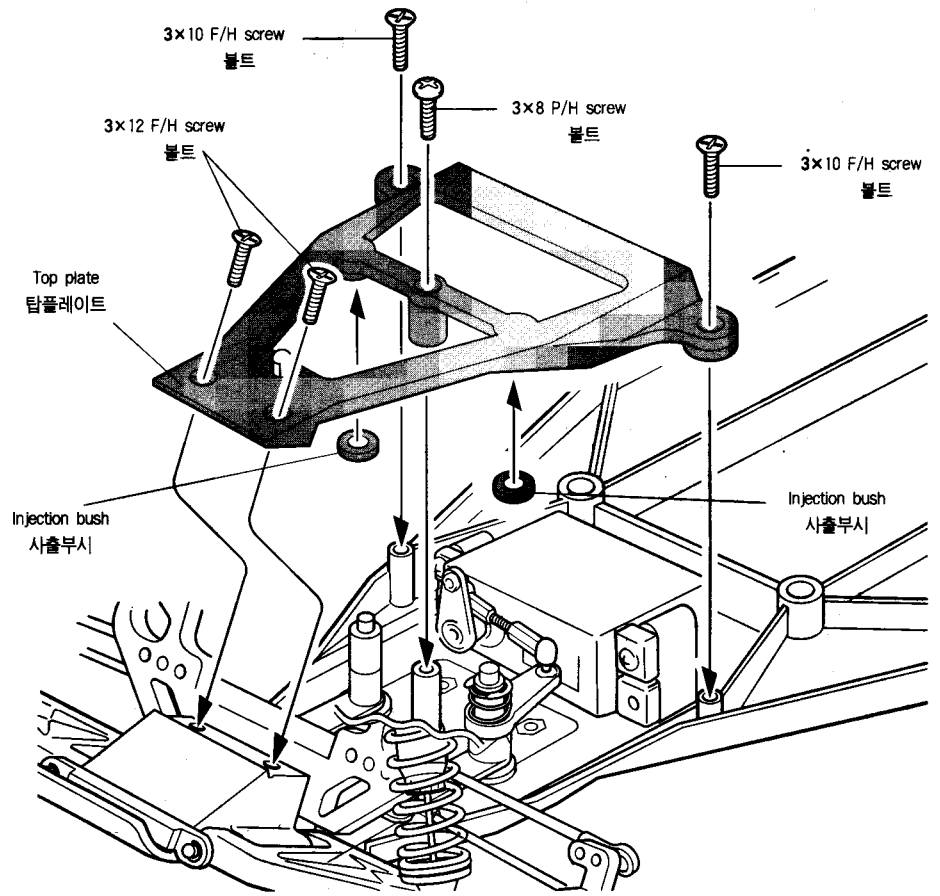



11 GR-E

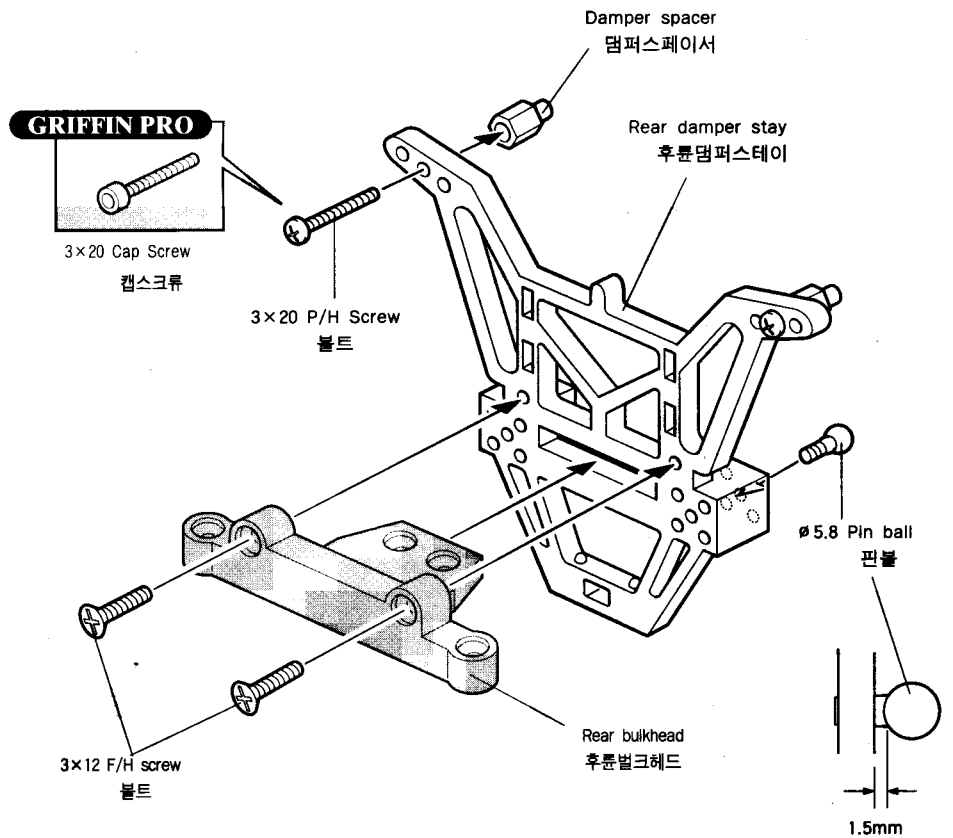

-  3x12 F/H screw 2
볼트
-  3x10 F/H screw 2
볼트
-  3x8 P/H screw 1
볼트

12 GR-F



-  \varnothing 5.8 Pin ball 2
핀볼
-  3x12 F/H screw 2
볼트
-  3x20 P/H Screw 2
볼트

GRIFIN PRO



3x20 Cap Screw 2
캡스크류

13 GR-C

3x46 Hinge pin 2
힌지핀

ø 2 E-Ring 4
E-링

3x12 F/H screw 4
볼트

■ NEO GRIFFIN 네오그리핀

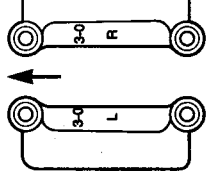

■ GRIFFIN Pro 그리핀프로

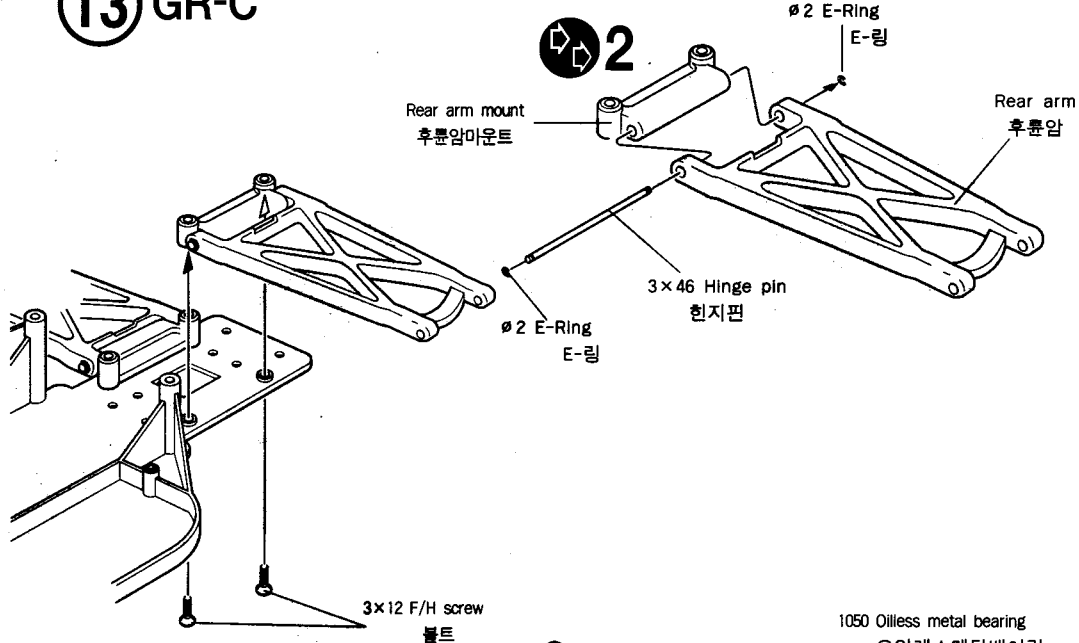
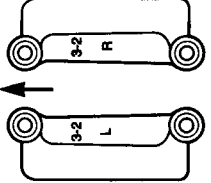

14 GR-C

Axle shaft
액슬샤프트

1050 Oilless metal bearing
오일레스메탈베어링

ø 5.8 Pin ball
핀볼

Rear hub
후륜허브

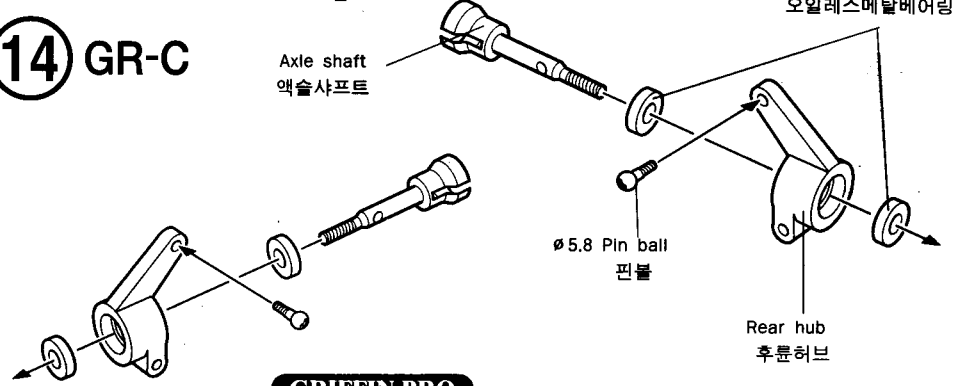

GRIFFIN PRO

1050 Ball bearing
볼베어링

Universal drive shaft
유니버설드라이브샤프트

ø 5.8 Pin ball
핀볼

Universal drive shaft
유니버설드라이브샤프트

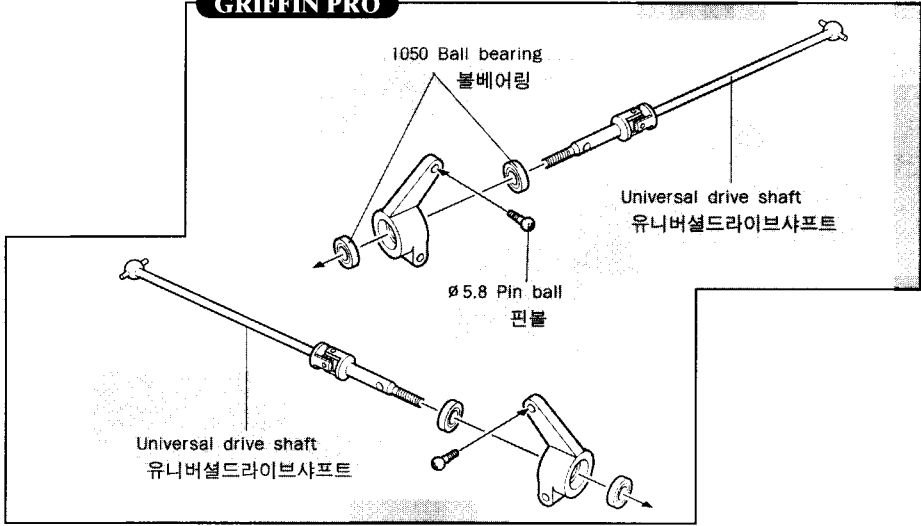

Hub spacer
허브스페이서

Hub spacer
허브스페이서

3x33 Hinge pin
힌지핀

ø 2 E-Ring
E-링

ø 2 E-Ring
E-링

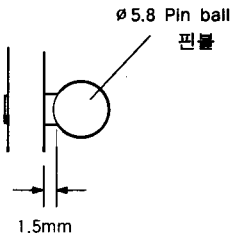
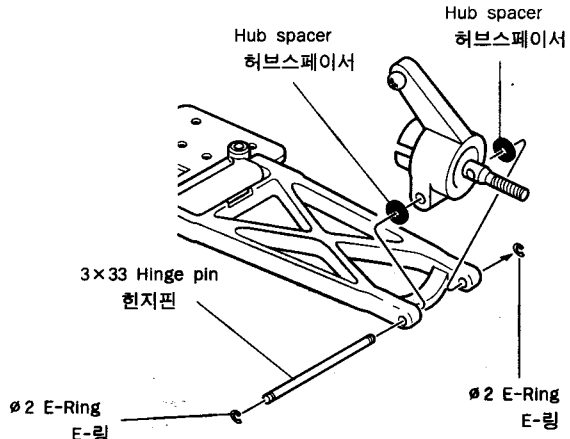

GRIFFIN PRO

1050 Ball bearing 4
볼베어링

Hub spacer
허브스페이서

3x33 Hinge pin 2
힌지핀

ø 2 E-Ring 4
E-링

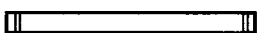
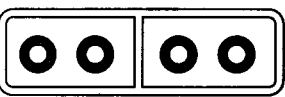

15 GR-B

3×20 Shaft 1
샤프트

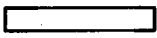

1510 Oilless metal bearing 2
오일레스메탈베어링

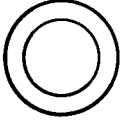

Bearing bush 2
베어링 부시



2×14 P/H
Tapping screw 4
비스



4×4 Set screw 2
육각볼트



1050 Oilless metal bearing 4
오일레스메탈베어링



2×8.8 Pin 1
핀



∅4 C-Stop ring 1
스톱링





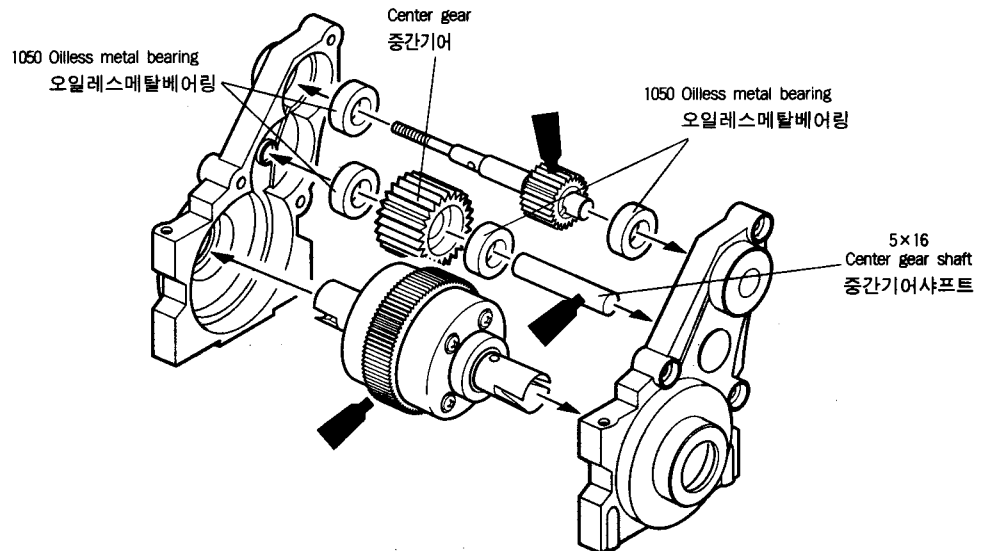
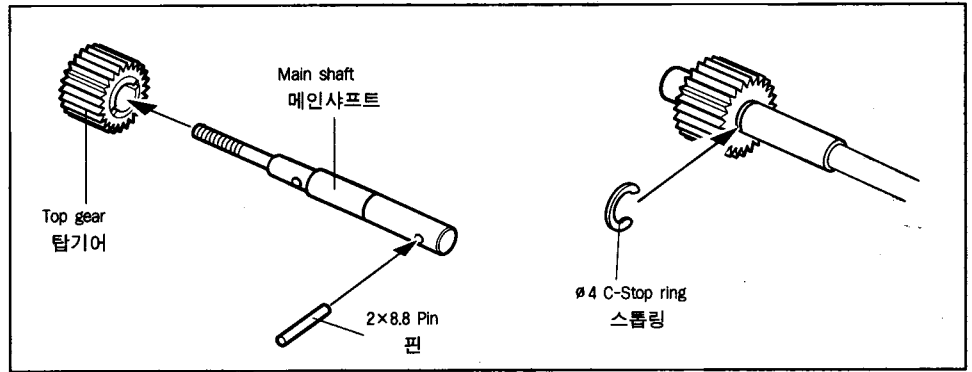
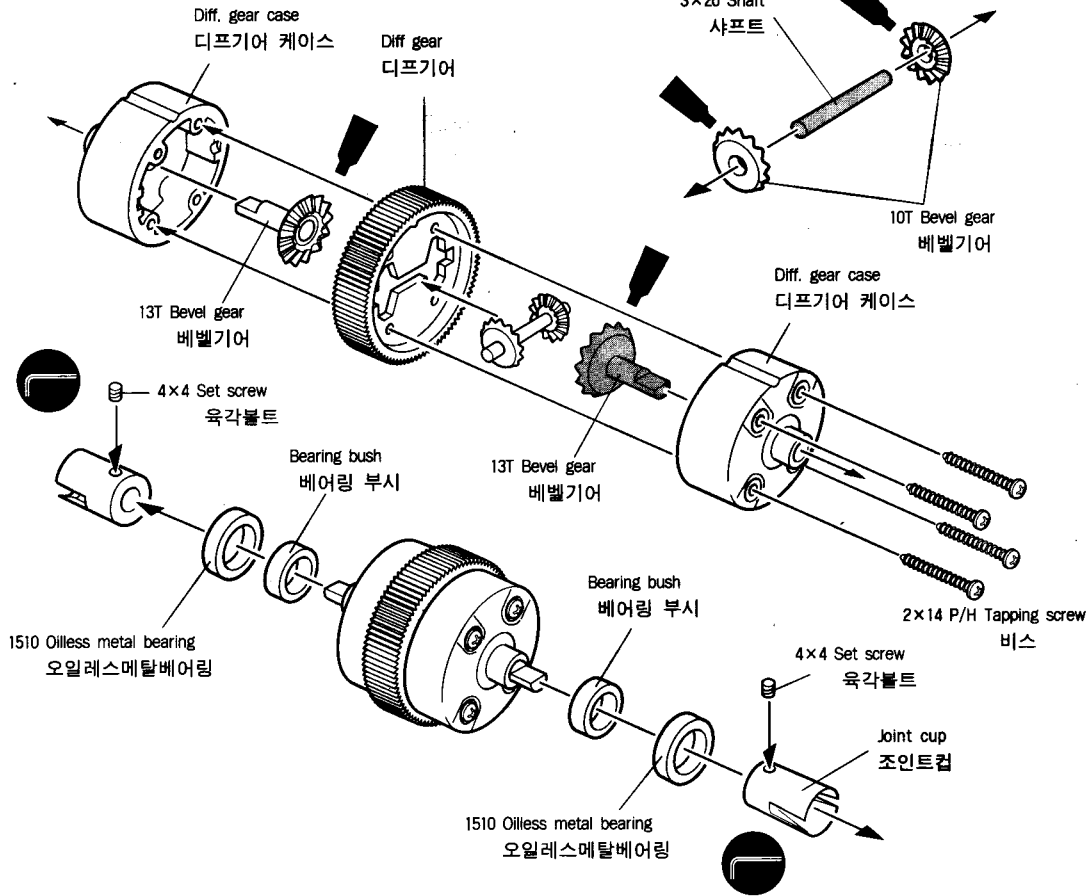



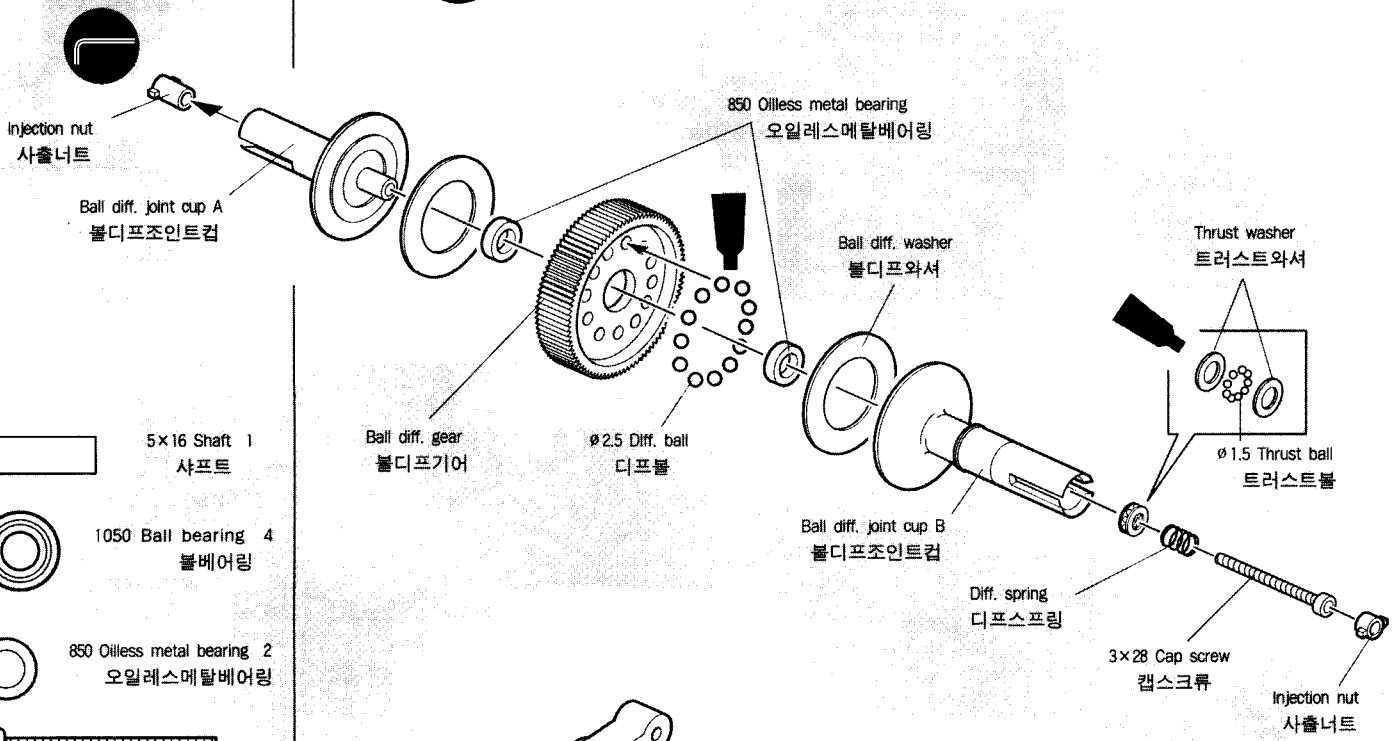

5×16
Center gear shaft 1
중간기어샤프트



15 GR-B



-  5x16 Shaft 1
샤프트
-  1050 Ball bearing 4
볼베어링
-  850 Oilless metal bearing 2
오일레스메탈베어링
-  3x28 Cap screw 2
캡스크류
-  1510 Ball bearing 2
볼베어링
-  Ø 1.5 Thrust ball 9
트러스트볼
-  Ø 2.5 Diff. ball 12
디프볼
-  Thrust washer 2
트러스트와셔

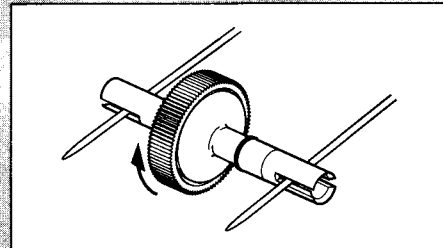
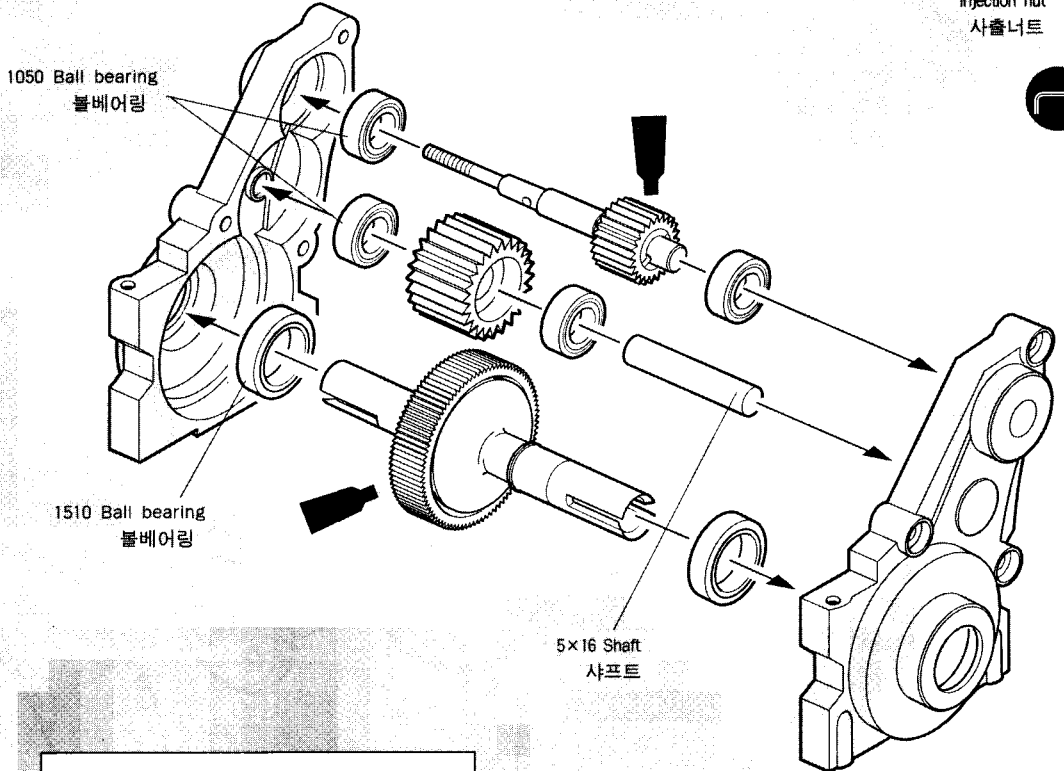

The differentials should be tightened until the gear can not be rotated when both of the diff joint cup are held.
그림과 같이 양쪽의 디프조인트컵을 고정시키고 디프기어가 슬립하지 않을 정도까지 죄어본다. 너무 세게 죄지 말 것. 무리하게 죄면 디프와셔가 파손될 수 있다.

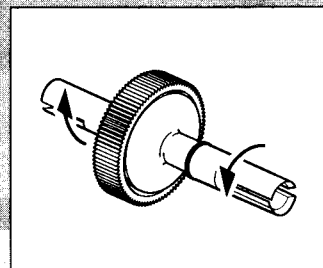

The differentials should spin smoothly after they are assembled.
디프기어는 그림과 같이 부드럽게 움직이도록 조립한다. 너무 세게 죄지 않도록 주의.

16 GR-B · H

1.5×6 Spring pin 1
스프링핀

3×25 P/H Screw 3
볼트

*When assemble to motor mount do not lock too much tighten.
모터마운트 조립시 무리하게 조이지 않는다.

Dust bush
더스트부시

Motor mount
모터마운트

Gear box spacer
기어박스스페이서

Gear box spacer
기어박스스페이서

1.5×6 Spring pin
스프링핀

3×25 P/H Screw
볼트

3×25 P/H Screw
볼트

17 GR-B

∅3 Nylon nut
나일론너트

GRIFFIN PRO

*Do not use excessive force when tightening a Nylon nut.
나일론너트를 너무 세게 죄지 않는다.
무리하게 죄면 트러스트와셔가 파손될 수 있다.

∅3 Nylon nut 1
나일론너트

3×5 P/H Screw 2
볼트

3×11 Washer 1r
와셔

3×11 Washer 1r
와셔

GRIFFIN PRO

Thrust washer
트러스트와셔

∅1.5 Thrust ball
트러스트볼

*Do not lock too much tighten.
볼트를 조일 때 무리하게 조이지 않는다.

Spur spring
스퍼스프링

3×5 P/H Screw
볼트

Spur gear
스퍼기어

3×11 Washer
와셔

3×5 P/H Screw
볼트

Aluminum Spur gear adapter
알루미늄 스퍼기어 어댑터

GRIFFIN PRO

Slipper disk
슬리퍼디스크

Tepron slipper pad
테프론슬리퍼패드



3x8 Washer 2
와셔



3x3 Set screw 1
육각렌치볼트



3x5 P/H Screw 4
볼트

18 GR-H · Q

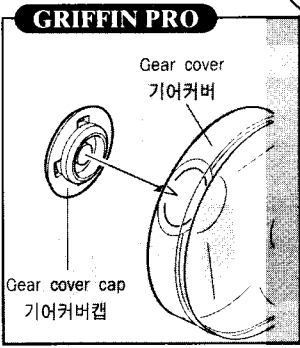
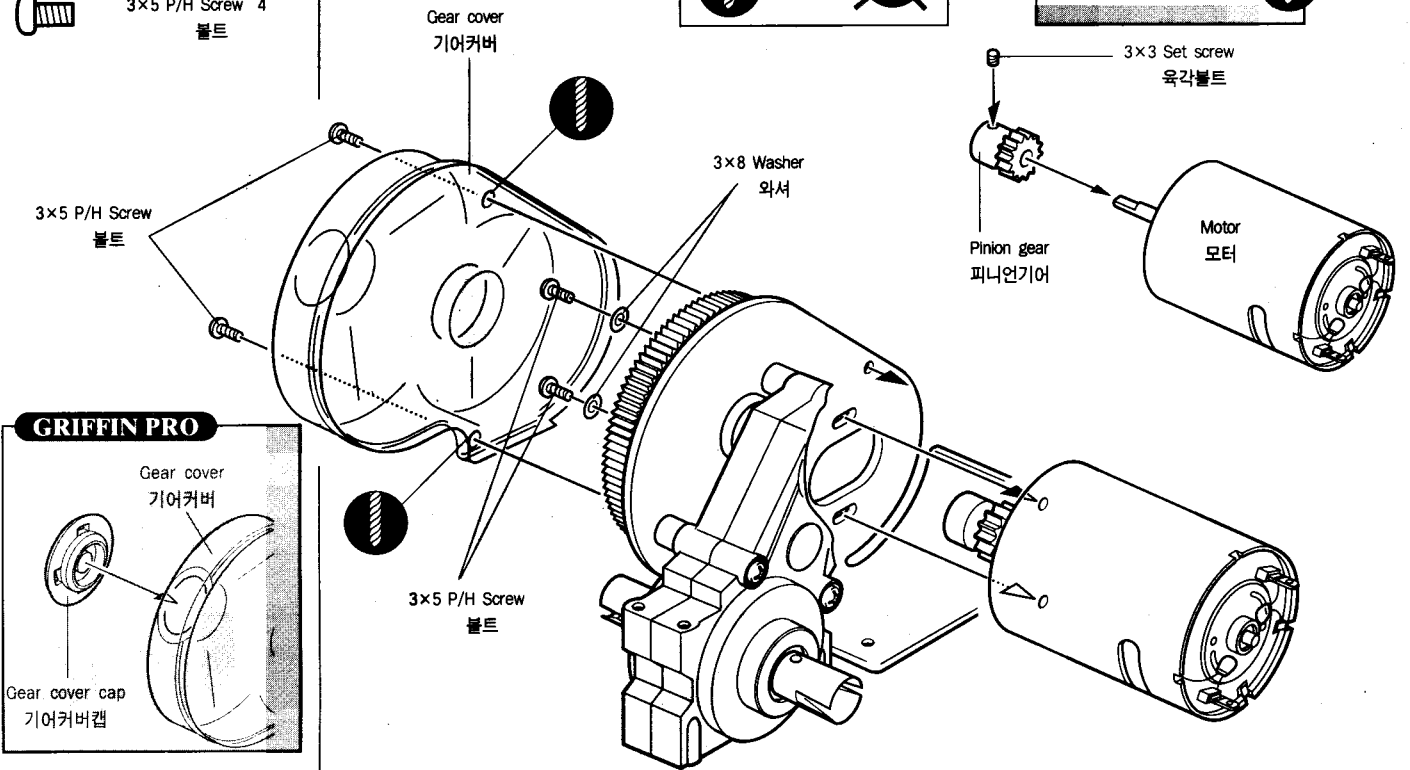
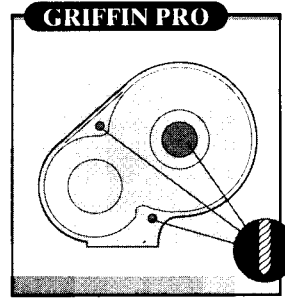
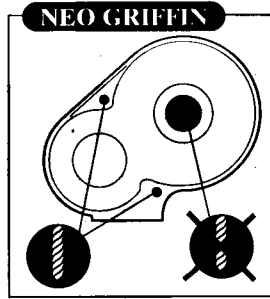

19 GR-B · H





3x6 F/H screw 2
볼트

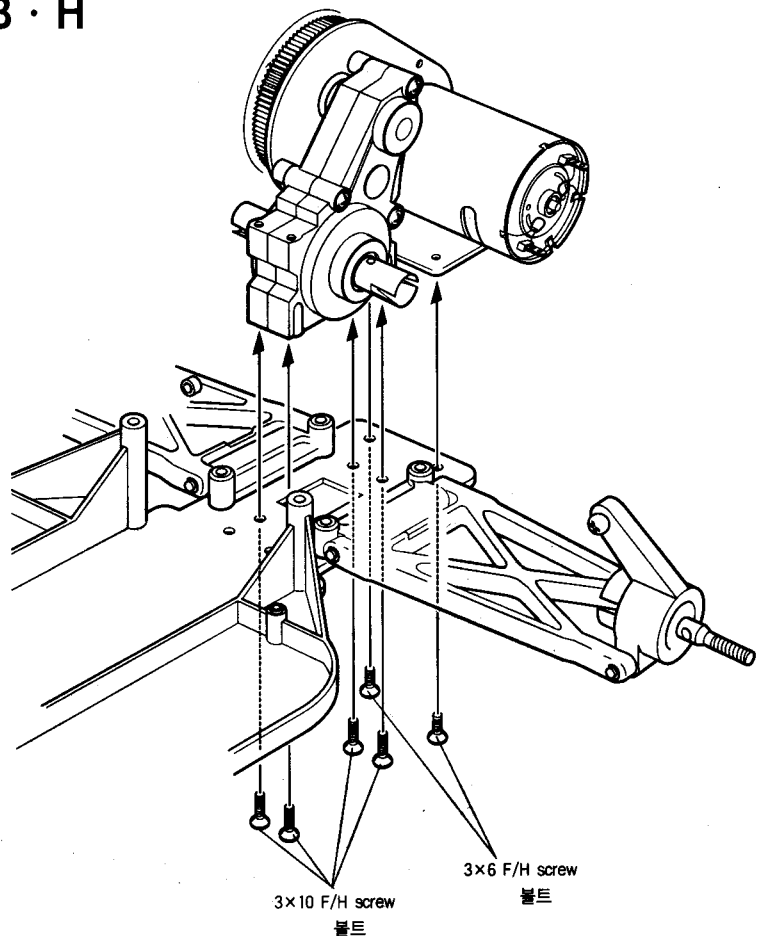

3x10 F/H screw 4
볼트



20 GR-F

-  3x10 F/H screw
볼트
-  3x12 F/H screw
볼트

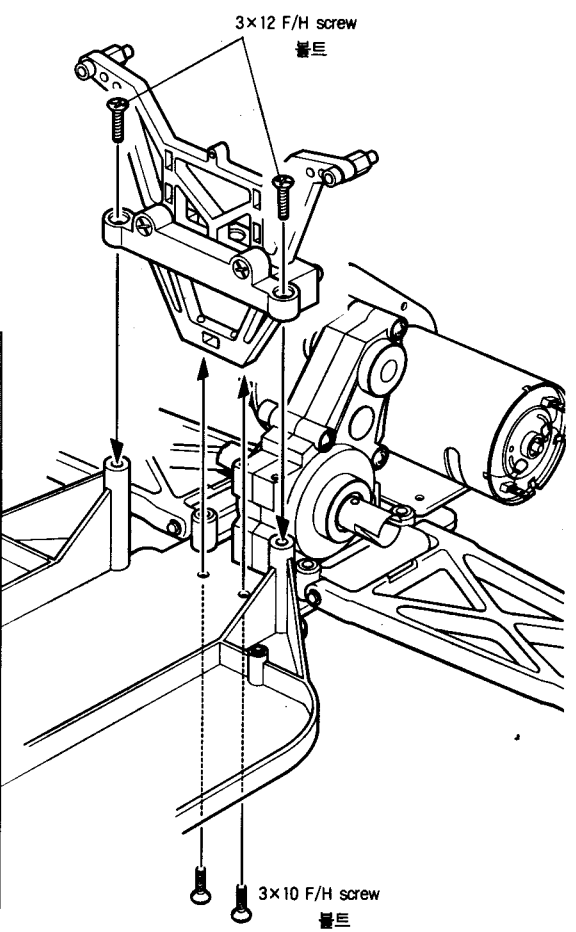
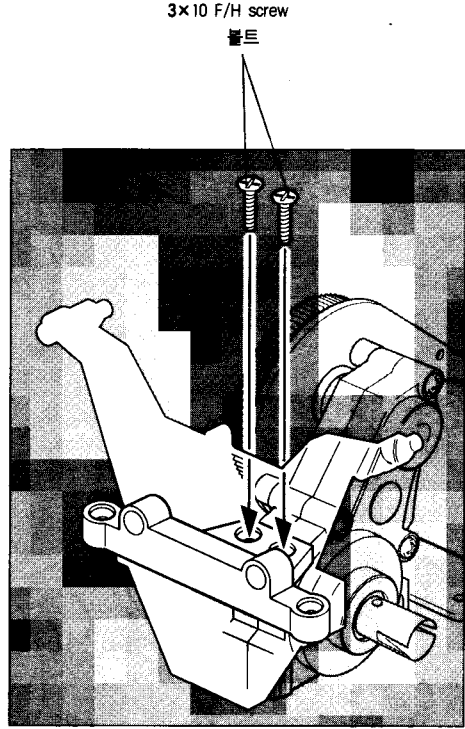

21 GR-C

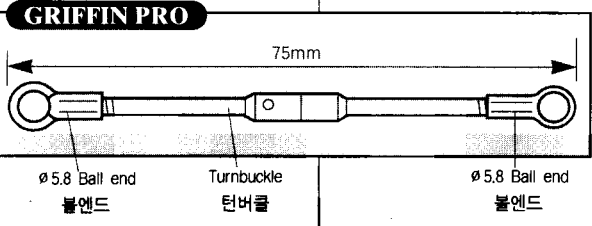
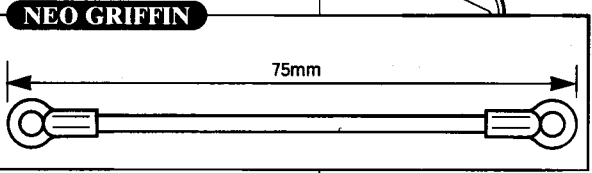
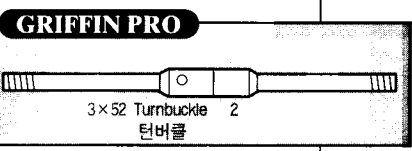
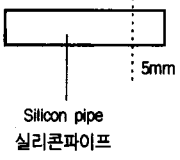

2

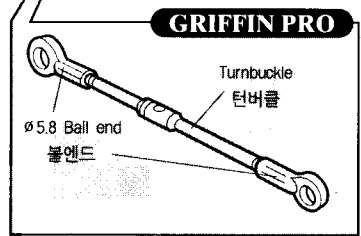
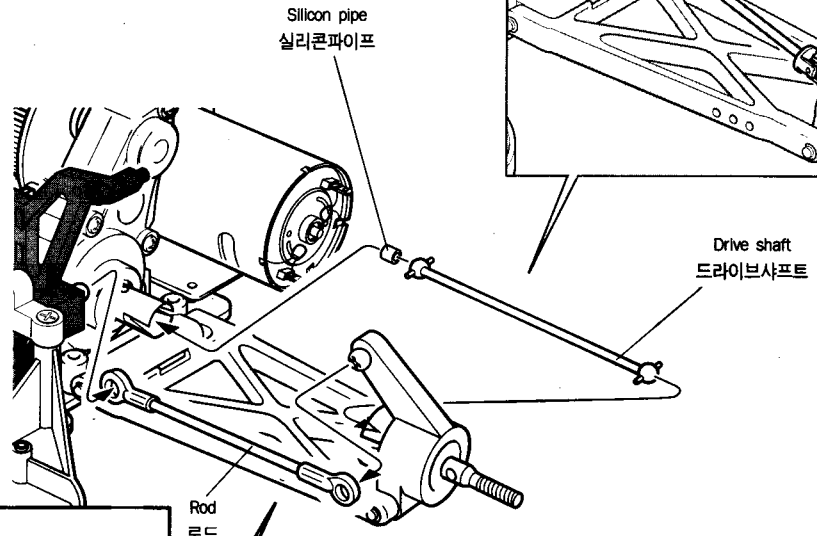
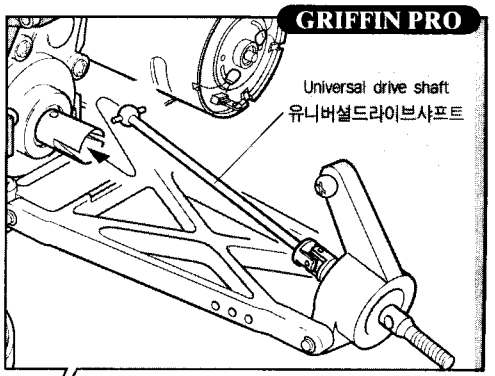

2

24 GR-G

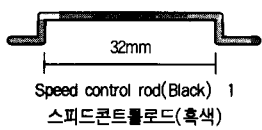
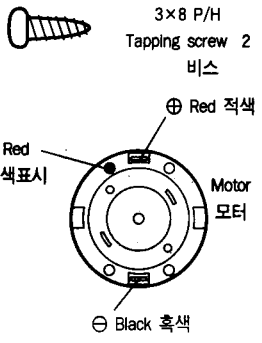
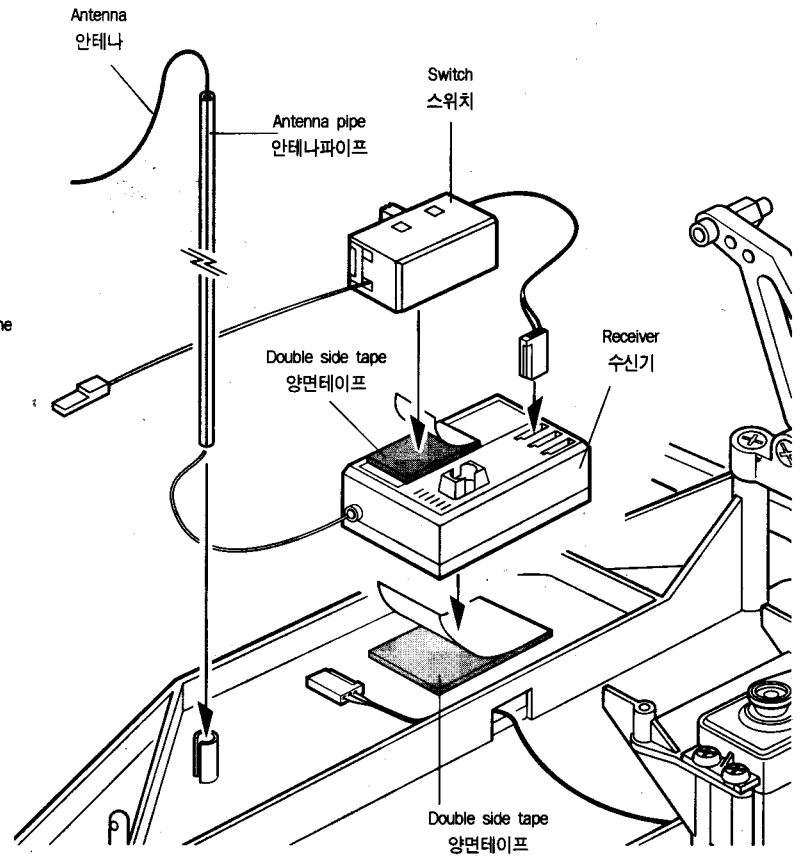
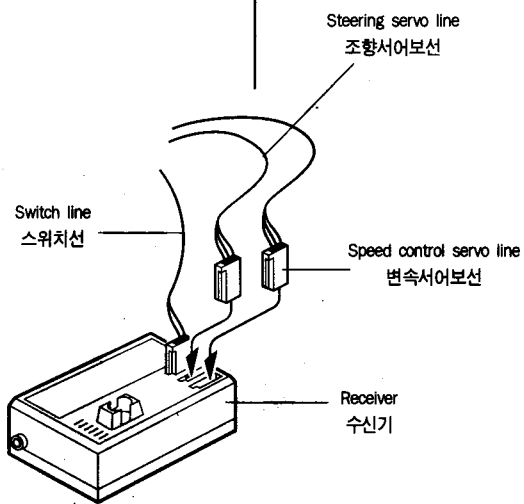

25 GR-Q

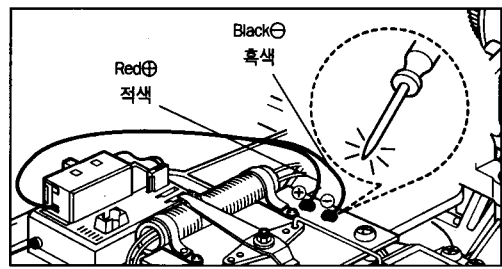
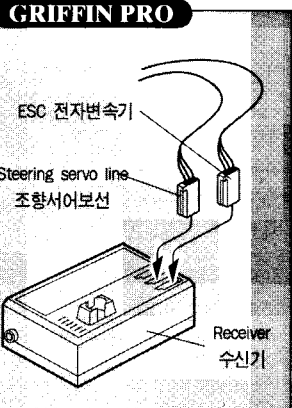
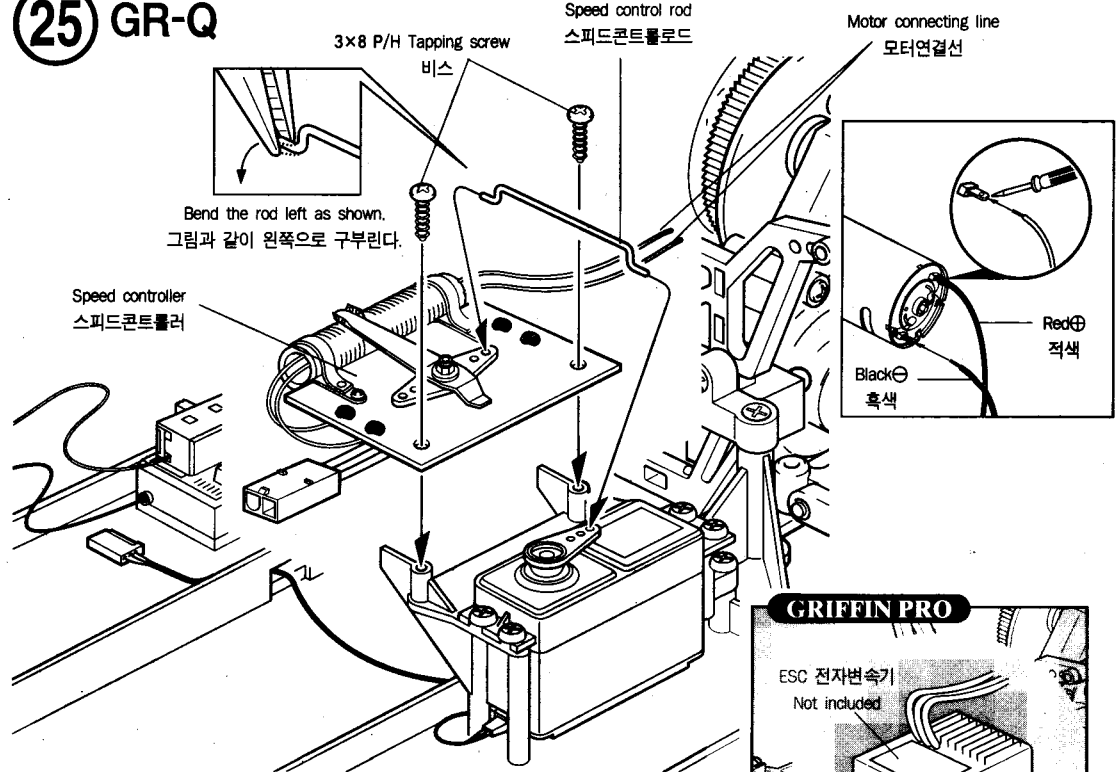
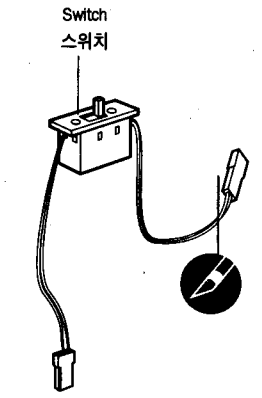

*스위치선을 자르고 그림과 같이 ⊕⊖를 확인한 후 납땀한다.

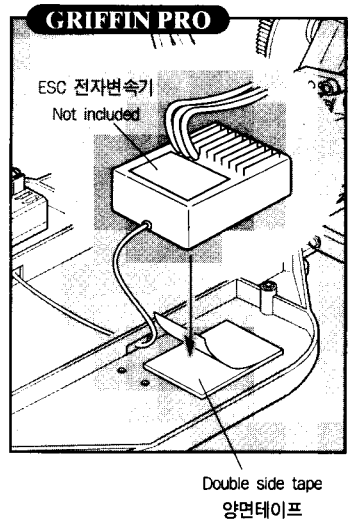

26 GR-A · G

3×12 F/H
Tapping screw 2
비스

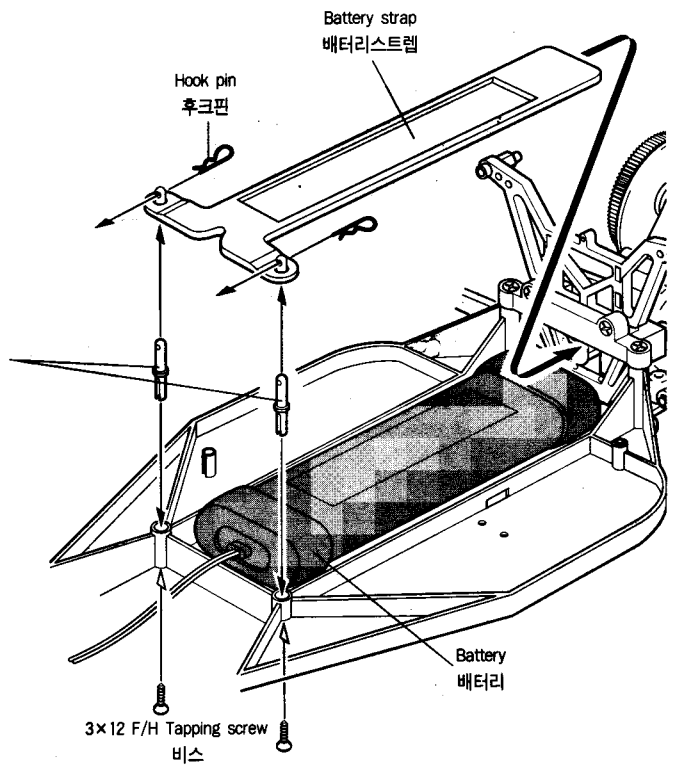
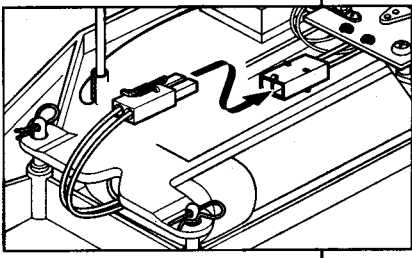
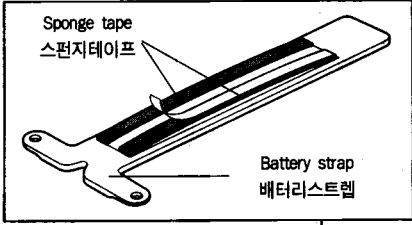

27 GR-C · D · J

1050 Oilless metal bearing 4
오일레스메탈베어링

GRIFFIN PRO

1050 Ball bearing 4
볼베어링

∅4 Nylon nut 4
나일론너트

2.5×8.5 Pin 2
핀

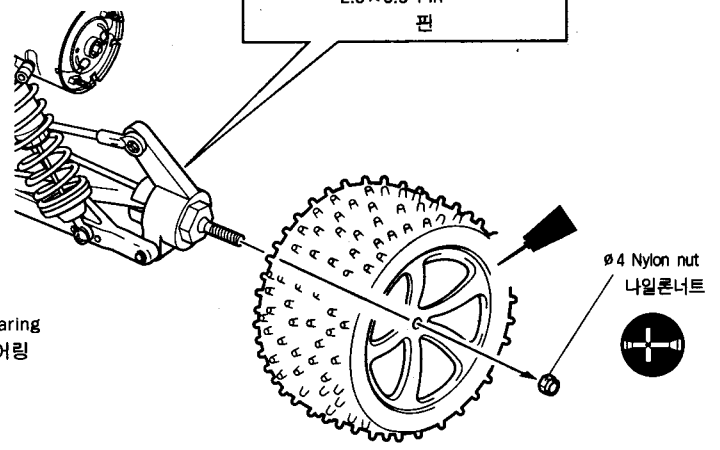
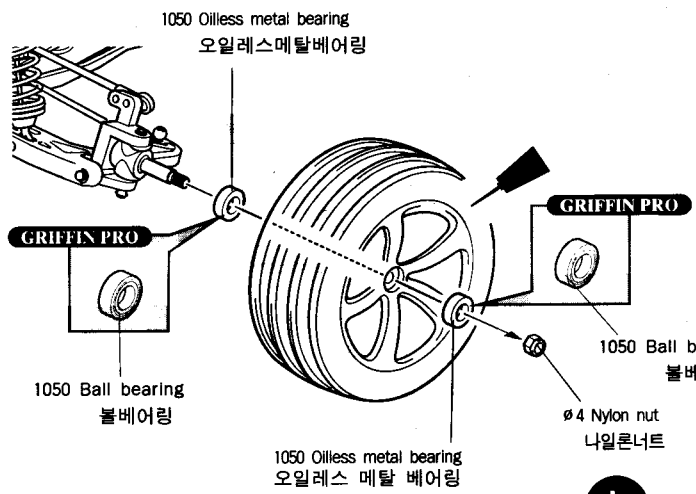
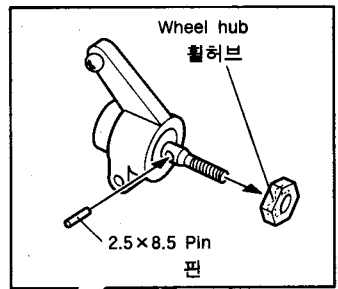
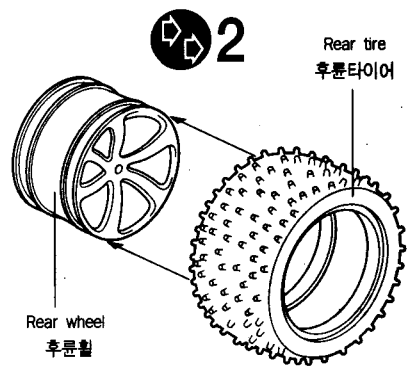
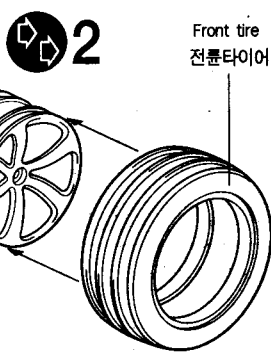

3x5 P/H Screw 2
볼트

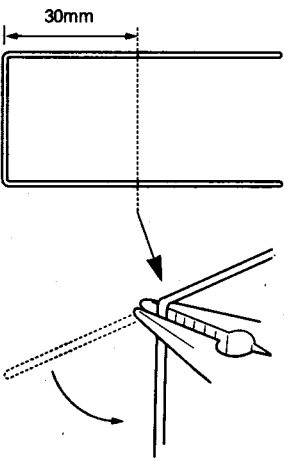

28 GR-I

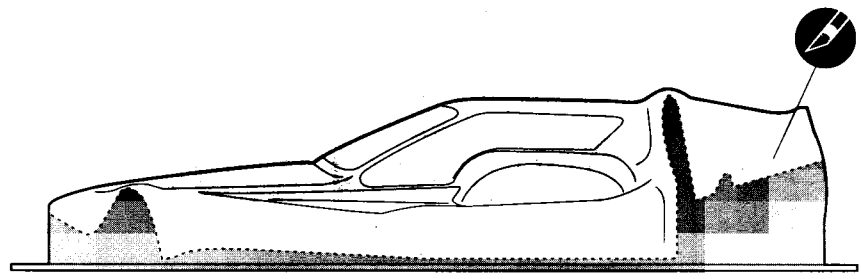
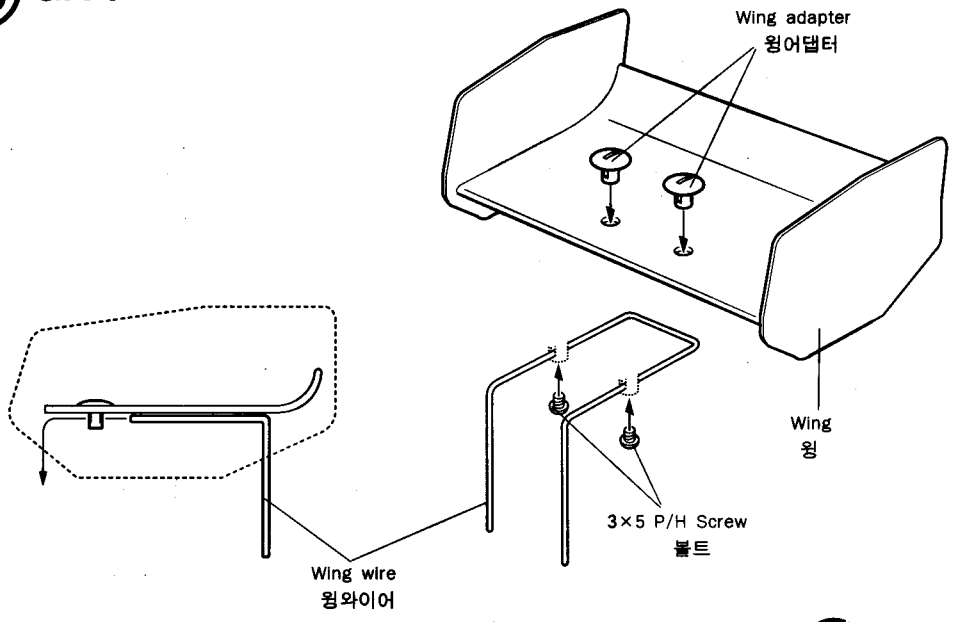

*부분에 얇은 가위 등으로 잘라낸다.

29

■ NOTICE (참고)
Attach the decals
as you want.
스티커는 상지그림을
참조하여 임의대로 붙인다.

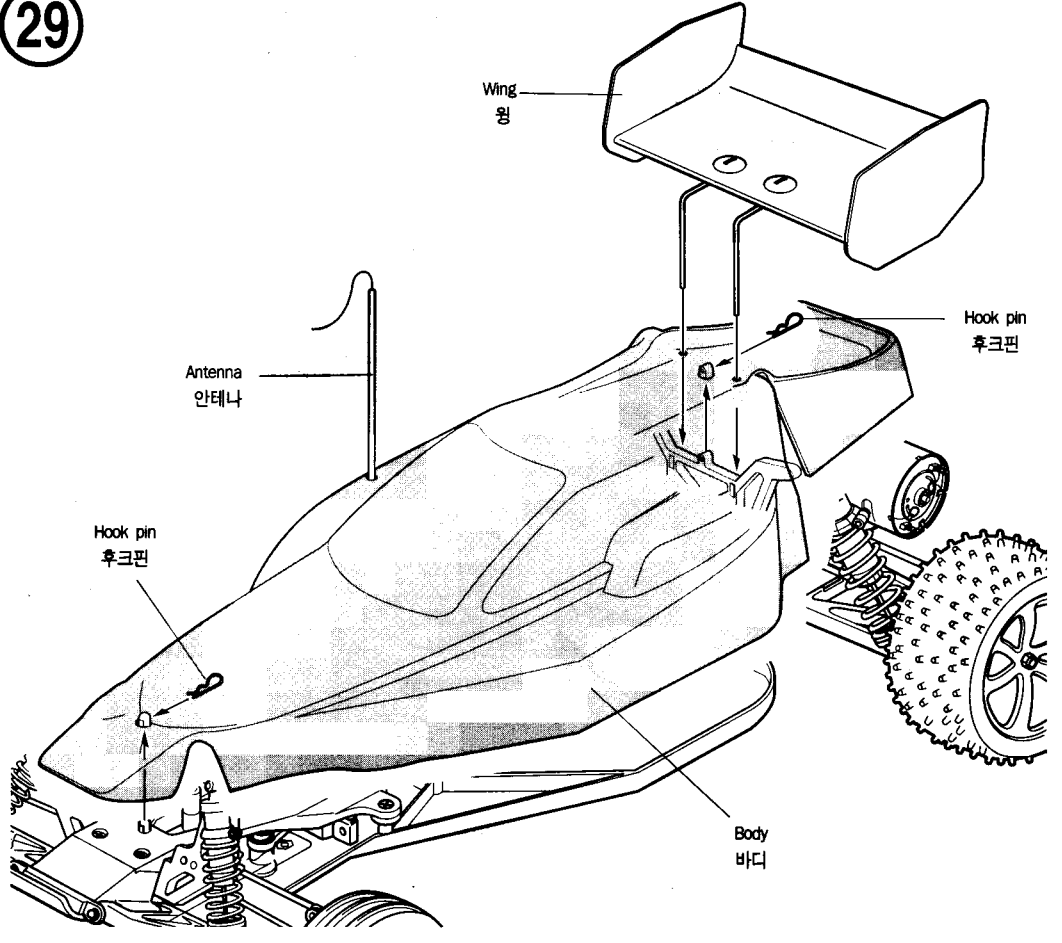

NEO GRIFFIN

PART NAME	INJECTION PARTS	SUB PARTS
GR-A Main chassis 메인체시	<ul style="list-style-type: none"> · Main chassis 메인체시 1EA · Battery strap post 배터리 스트랩 포스트 1EA 	<ul style="list-style-type: none"> · 3×12 F/H Tapping screw 비스 2EA
GR-B Gear box 기어박스	<ul style="list-style-type: none"> · Gear box parts 기어박스파트 1Set · Spur gear 스퍼기어 1EA · Top gear 탑기어 1EA · Center gear 중간기어 1EA · Diff gear 디프기어 1EA · Diff gear case (L,R) 디프기어케이스(좌,우) 1EA 	<ul style="list-style-type: none"> · Main shaft 메인샤프트 1EA · Joint cup(Large) 조인트컵(대) 2EA · 5×16 Center gear shaft 중간기어샤프트 1EA · 3×20 Diff shaft 디프샤프트 1EA · 13T Bevel gear 베벨기어 2EA · 10T Bevel gear 베벨기어 2EA · 2×8.8 Pin 핀 1EA · Bearing bush 베어링부시 2EA · 15×6 Spring pin 스프링핀 1EA · 1050 Oilless metal bearing 메탈베어링 4EA · 1510 Oilless metal bearing 메탈베어링 2EA · 3×5 P/H Screw 볼트 2EA · 3×10 F/H 볼트 6EA · 2×14 P/H Tapping screw 비스 4EA · Grease 그리스 1EA · 4×4 Set screw 육각볼트 2EA · 0.5×3×11 Washer 와셔 1EA · Ø3 Nylon nut 나일론너트 1EA · Spur spring 스퍼스프링 1EA · Ø4 C-Stop ring C형스톱링 1EA · Aluminum Spur gear adapter 알루미늄 스퍼기어 어댑터 1EA
GR-C Rear suspension 후륜서스펜션	<ul style="list-style-type: none"> · Rear arm 후륜암 2EA · Rear hub 후륜허브 2EA · Rear hub spacer 후륜허브스페이서 1Set · Arm mount 3-0° 암마운트 1Set · Feel hub 휠허브 1Set 	<ul style="list-style-type: none"> · 3×46 Hinge pin 힌지핀 2EA · 3×33 Hinge pin 힌지핀 2EA · Ø2 E-Ring 링 8EA · Ø5.8 Pinball 핀볼 2EA · 3×12 F/H Screw 볼트 4EA · 2.5×8.5 Pin 핀 2EA · Ø4 Nylon nut 나일론너트 2EA · 1050 Oilless metal bearing 오일레스메탈베어링 4EA · 66mm Drive shaft 드라이브샤프트 2EA · Axle shaft 액슬샤프트 2EA
GR-D Front suspension 전륜서스펜션	<ul style="list-style-type: none"> · Front arm 전륜암 2EA · Knuckle arm 너클암 1Set · Front hub 전륜허브 1Set · Front bulk head 전륜벌크헤드 1EA · Bumper 범퍼 1EA · Hinge pin bracer 힌지핀브레이서 1EA · Ø4.3 Ball end 볼엔드 4EA · Ø5.8 Ball end 볼엔드 8EA 	<ul style="list-style-type: none"> · Front axle shaft 전륜액슬샤프트 2EA · 3×40 Hinge pin 힌지핀 2EA · 3×26.5 Hinge pin 힌지핀 4EA · Ø5.8 Pin ball 핀볼 2EA · Ø4.3 Pin ball 핀볼 2EA · Ø4 Nylon nut 나일론너트 2EA · Ø2E-Ring E-링 12EA · 3×3 Set screw 육각볼트 2EA · 1050 Oilless metal bearing 오일레스메탈베어링 4EA · 3×50 Rod 로드 4EA · 3×65 Rod 로드 2EA · Silicon tube 실리콘튜브 20mm
GR-E Steering parts 스티어링파트	<ul style="list-style-type: none"> · Nose plate 노즈플레이트 1EA · Top plate 탑플레이트 1EA · Servo saver 서어보세이버 1Set · Servo horn 서어보혼 1Set · Ø4.3 Ball end 볼엔드 2EA · Injection bush 사출부시 1Set · Servo mount 서어보마운트 1Set 	<ul style="list-style-type: none"> · Steering post A 스티어링포스트A 1EA · Steering post B 스티어링포스트B 1EA · Steering rod 스티어링로드 1EA · 3×15 Rod 로드 1EA · Saver spring 세이버스프링 1EA · Ø4.3 Pin ball 핀볼 4EA · Ø5 E-Ring 링 1EA · Ø3 Nut 너트 4EA · 3×6 F/H Screw 볼트 4EA · 3×10 F/H Screw 볼트 8EA · 3×12 F/H Screw 볼트 2EA · 3×8 P/H Screw 볼트 1EA · 3×8 Washer 와셔 2EA · 3×8 P/H Tapping screw 비스 2EA · 2.6×10 P/H Tapping screw 비스 1EA
GR-F Damper stay parts 댐퍼스테이파트	<ul style="list-style-type: none"> · F/R Damper stay 전/후 댐퍼스테이 1Set · Damper spacer 댐퍼스페이서 1Set · Rear bulkhead 후륜벌크헤드 1EA 	<ul style="list-style-type: none"> · 3×20 P/H Screw 볼트 4EA · 3×12 F/H Screw 볼트 4EA · 3×10 F/H Screw 볼트 6EA · Ø3 Nylon nut 나일론너트 4EA · Ø5.8 Pin ball B 핀볼B 4EA
GR-G Battery strap parts 배터리스트랩파트	<ul style="list-style-type: none"> · Battery strap 배터리스트랩 1EA 	<ul style="list-style-type: none"> · Hook pin 후크핀 4EA · Double side tape 양면테이프 1EA · Sponge tape 단면스폰지테이프 1EA
GR-H Motor mount 모터마운트		<ul style="list-style-type: none"> · Motor mount 모터마운트 1EA · 3×6 F/H Screw 볼트 2EA · 3×8 Washer 와셔 2EA · Gear cover(PVC) 기어커버 1EA · 18T Pinion gear 피니언기어 1EA · 3×3 Set screw 육각볼트 1EA · 3×25 P/H Screw 볼트 3EA · 3×5 P/H Screw 볼트 4EA · 2mm Allen key 육각렌치 1EA · 2.5mm Allen key 육각렌치 1EA · ⊕ Wrench 십자렌치 1EA
GR-I Wing parts 윙파트	<ul style="list-style-type: none"> · Wing White 윙(백색) 1EA · Wing adapter 윙어댑터 1Set 	<ul style="list-style-type: none"> · Wing wire 윙와이어 1EA · 3×5 P/H Screw 볼트 2EA
GR-J Wheel 휠	<ul style="list-style-type: none"> · Front wheel (White) 전륜휠(백색) 2EA · Rear wheel (White) 후륜휠(백색) 2EA 	
GR-K Damper parts 댐퍼파트	<ul style="list-style-type: none"> · Damper body(Long) 댐퍼바디(대) 2EA · Damper body(Short) 댐퍼바디(소) 2EA · Damper cap(Upper) 댐퍼캡(상) 2EA · Damper cap(Lower) 댐퍼캡(하) 2EA · Spring guard 스프링가이드 2Sets · Ø5.8 Ball end 볼엔드 4EA · Damper piston 댐퍼피스톤 2Sets 	<ul style="list-style-type: none"> · 1.0×42×10 Spring 스프링 2EA · 1.0×60×12 Spring 스프링 2EA · 50mm Damper shaft 댐퍼샤프트 2EA · 39mm Damper shaft 댐퍼샤프트 2EA · Ø5.8 ball 링크볼 4EA · Ø2.5 E-Ring 링 8EA · 2.6×10 P/H Tapping screw 4EA · 3×12 P/H Screw 볼트 2EA · Silicon O-Ring 실리콘O링 8EA · 3×10 P/H Screw 볼트 2EA · Damper oil 댐퍼오일 2EA · Rubber cap 러버캡 4EA
GR-Q Speed control parts 변속기파트	<ul style="list-style-type: none"> · Speed controller mount 변속기마운트 1EA 	<ul style="list-style-type: none"> · Speed controller 레이싱변속기 1EA · 3×15 P/H Tapping screw 1EA · 3×8 P/H Tapping screw 6EA · 3×10 F/H Screw 볼트 2EA · Speed controller rod 변속기로드 1EA · RS 540 Motor 모터 1EA · 3×8 Washer 와셔 4EA

· PVC body 바디 1EA · Front tires 전륜타이어 2EA · Rear tires 후륜타이어 2EA
 · Griffin sticker 그리핀스티커 1EA · Antenna pipe 안테나파이프 1EA

GRIFFIN PRO

PART NAME	INJECTION PARTS	SUB PARTS
GR-A Pro Main chassis 메인채시	<ul style="list-style-type: none"> · Main chassis 메인채시 1EA · Battery strap post 배터리 스트랩 포스트 1EA 	<ul style="list-style-type: none"> · 3×12 F/H Tapping screw 비스 2EA
GR-B Pro Gear box 기어박스	<ul style="list-style-type: none"> · Gear box parts 기어박스파트 1Set · Spur gear 스퍼기어 1EA · Top gear 탑기어 1EA · Center gear 중간기어 1EA · Ball diff. gear 볼디프기어 1EA · Ball diff. injection nut 볼디프사출너트 1EA 	<ul style="list-style-type: none"> · Main shaft 메인샤프트 1EA · 5×16 Center gear shaft 중간기어샤프트 1EA · 2×8.8 Pin 핀 1EA · Ø2.5 Ball볼 12EA · Ball diff. joint cup A.B 볼디프조인트컵 1Set · Slipper disk A.B 슬리퍼디스크 1Set · Teflon slipper disk 테프론슬리퍼디스크 1EA · Ball diff disk washer 볼디프디스크와셔 2EA · Thrust washer 트러스트와셔 4EA · 15×6 Spring pin 스프링핀 1EA · 1050 Ball bearing 볼베어링 4EA · 1510 Ball bearing 볼베어링 2EA · 850 O/Wless metal bearing 오일레스메탈베어링 2EA · 3×28 Cap screw 캡스크류 1EA · 3×10 F/H Screw 볼트 6EA · Ø1.5 Ball 볼 18EA · 3×5 P/H Screw 볼트 2EA · Silicon grease 그리스 1EA · Ø3 Nylon nut 나일론너트 1EA · Spur spring 스퍼스프링(7mm) 1EA · Ø4 C-Stop ring C형스톱링 1EA · Diff. spring 디프스프링 1EA
GR-C Pro Rear suspension 후륜서스펜션	<ul style="list-style-type: none"> · Rear arm 후륜암 2EA · Rear hub 후륜허브 2EA · Rear hub spacer 후륜허브스페이서 1Set · Arm mount 3-2" 암마운트 1Set · Wheel hub 휠허브 1Set 	<ul style="list-style-type: none"> · 3×46 Hinge pin 힙지핀 2EA · 3×33 Hinge pin 힙지핀 2EA · Ø2 E-Ring 링 8EA · Ø5.8 Pin ball 핀볼 2EA · 3×12 F/H Screw 볼트 4EA · 2.5×8.5 Pin 핀 2EA · 1050 Ball bearing 볼베어링 4EA · Universal shaft 유니버셜 샤프트 2EA · Ø4 Nylon nut 나일론너트 2EA
GR-D Pro Front suspension 전륜서스펜션	<ul style="list-style-type: none"> · Front arm 전륜암 2EA · Knuckle arm 너클암 1Set · Front hub 전륜허브 1Set · Front bulk head 전륜벌크헤드 1EA · Bumper 범퍼 1EA · Hinge pin bracer 힙지핀브레이서 1EA · Ø4.3 Ball end 볼엔드 4EA · Ø5.8 Ball end 볼엔드 8EA 	<ul style="list-style-type: none"> · Front axle shaft 전륜액셀샤프트 2EA · 3×40 Hinge pin 힙지핀 2EA · 3×26.5 Hinge pin 힙지핀 4EA · Ø5.8 Pin ball 핀볼 2EA · Ø4.3 Pin ball 핀볼 2EA · Ø4 Nylon nut 나일론너트 2EA · Ø2 E-Ring 링 12EA · 3×3 Set screw 육각볼트 2EA · 1050 Ball bearing 볼베어링 4EA · L 65 Turnbuckle 턴버클 2EA · L 52 Turnbuckle 턴버클 4EA
GR-E Pro Steering parts 스티어링파트	<ul style="list-style-type: none"> · Nose plate 노즈플레이트 1EA · Top plate 탑플레이트 1EA · Servo saver 서어보세이버 1Set · Servo horn 서어보혼 1Set · Injection bush 사출부시 1Set · Servo mount 서어보마운트 1Set · Ø4.3 Ball end 볼엔드 2EA 	<ul style="list-style-type: none"> · Steering post A 스티어링포스트A 1EA · Steering post B 스티어링포스트B 1EA · Steering rod 스티어링로드 1EA · 3×15 Rod 로드 1EA · Saver spring 세이버스프링 1EA · Ø4.3 Pin ball 핀볼 4EA · Ø5 E-Ring 링 1EA · Ø3 Nut 너트 4EA · 3×6 F/H Screw 볼트 4EA · 3×10 F/H Screw 볼트 8EA · 3×12 F/H Screw 볼트 2EA · 3×8 P/H Screw 볼트 1EA · 3×8 P/H Tapping 비스 2EA · 2.6×10 P/H Tapping 비스 1EA · 3×8 Washer 와셔 2EA
GR-F Pro Damper stay parts 댐퍼스테이파트	<ul style="list-style-type: none"> · F/R Damper stay 전/후 댐퍼스테이 1Set · Damper spacer 댐퍼스페이서 1Set · Rear bulkhead 후륜벌크헤드 1EA 	<ul style="list-style-type: none"> · 3×20 Cap screw 캡스크류 2EA · 3×10 F/H Screw 볼트 6EA · Ø3Nylon nut 나일론너트 4EA · Ø5.8 Pin ball 핀볼 4EA · 3×12 F/H Screw 볼트 4EA
GR-G Pro Battery strap parts 배터리스트랩파트	<ul style="list-style-type: none"> · Battery strap 배터리스트랩 1EA 	<ul style="list-style-type: none"> · Body pin 바디핀 4EA · Double side tape 양면테이프 1EA · Sponge tape 1EA
GR-H Pro Motor mount 모터마운트		<ul style="list-style-type: none"> · Motor mount 모터마운트(보라색) 1EA · 3×6 F/H Screw 볼트 2EA · Gear cover 기어커버 1EA · 18T Pinion gear 피니언기어 1EA · 3×8 Washer 와셔 2EA · 3×3 Set screw 육각볼트 1EA · 3×25 P/H Screw 볼트 3EA · 3×5 P/H Screw 볼트 4EA
GR-I Pro Wing parts 윙파트	<ul style="list-style-type: none"> · Wing 윙(형광노랑) 1EA · Wing adapter 윙어댑터 1Set 	<ul style="list-style-type: none"> · Wing wire 윙와이어 1EA · 3×5 P/H Screw 볼트 2EA
GR-J Pro Wheel 휠	<ul style="list-style-type: none"> · Front wheel 전륜휠(형광노랑) 2EA · Rear wheel 후륜휠(형광노랑) 2EA 	
GR-K Pro Damper parts 댐퍼파트	<ul style="list-style-type: none"> · Spring guard 스프링가이드 2Sets · Ø5.8 Ball end 볼엔드 4EA · Damper piston 댐퍼피스톤 2Sets 	<ul style="list-style-type: none"> · 1.0×42×10 Spring 스프링 2EA · 1.0×60×12 Spring 스프링 2EA · 50mm Damper shaft 댐퍼샤프트 2EA · 39mm Damper shaft 댐퍼샤프트 2EA · Ø5.8 Ball 볼 4EA · Ø2.5 E-Ring 링 8EA · 2.6×10 P/H Tapping screw 4EA · C-Ring 링 4EA · Silicon O-Ring 실리콘O링 8EA · Damper oil 댐퍼오일 2EA · Rubber cap 러버캡 4EA · 3×10 Cap screw 캡스크류 2EA · 3×12 Cap screw 캡스크류 2EA · Damper body(42mm) 댐퍼바디(보라색) 2EA · Damper body(32mm) 댐퍼바디(보라색) 2EA · Damper cap 댐퍼캡(보라색) 4EA
GR-H Pro Wrench sets 렌치세트		<ul style="list-style-type: none"> · ⊕Wrench 십자렌치(비스트) 1EA · 1.5 mm L wrench L 렌치 1EA · 2 mm L wrench L 렌치 1EA · 2.5 mm L wrench L 렌치 1EA

· P·C body 바디 1EA · Front tires 전륜타이어 2EA
 · Rear tires 후륜타이어 2EA · Griffin Pro sticker 그리핀 프로 스티커 1EA
 · Antenna pipe 안테나파이프 1EA

- 직매점 겸 A/S센터 삼선교: 742-9293, 대치동: 552-9293, 양재동: 575-9997, 용산: 706-9293
- 총판점 겸 A/S센터 노원아카데미: 907-0940, 양천아카데미: 691-7108, 강남아카데미: 522-1577, 경기아카데미: (0343)458-5591,
 강북아카데미: 762-0980, 부산아카데미: (051)293-7449, 대구아카데미: (053)744-9293
- A/S센터 본사: 908-7000(교환147), 동대문: 745-9293, 천호동: 473-9293

♣ 고객상담문의 : **080-969-7000**

★ 홈페이지 (HOME PAGE) <http://www.academy.co.kr>
<http://www.academyhobby.com>



ACADEMY PLASTIC MODEL CO., LTD.
 273-64, Suyu-dong, Kangbuk-gu, Seoul, Korea
 TEL:82-2-908-7000 FAX:82-2-997-3003