

ACADEMY

HOBBY MODEL KITS

SB V2

1/10 SCALE EP 4WD BUGGY



Specifications

TOE-IN _ Front Adjustable / Rear 2°
INTERNAL GEAR RATIO _ 2.3:1
CASTER _ Front 17° (Hub: 7° / Arm: 10°) / Rear 2°
TREAD _ Front 212mm / Rear 200mm
WHEEL BASE _ 275mm

INSTRUCTION MANUAL

- Ball Diff ■ Ball Bearing (17ea) ■ Front Universal Drive Shaft
- 2.5mm FRP Chassis ■ 2 way Motor & Battery Location System
- Shaft Drive 4WD System ■ Slipper Clutch ■ Oil Damper
- 2mm FRP Upper Deck ■ Semi Cam Type Al. Motor Mount
- 2.5mm FRP 새시 ■ 2mm FRP 어퍼 데크 ■ 슬리퍼 클러치 ■ 볼 디프
- 볼 베어링 (17개) ■ 오일 댐퍼 ■ 세미 캠 타입 알루미늄 모터 마운트
- 2웨이 모터 & 배터리 로케이션 시스템
- 프론트 유니버설 드라이브 샤프트
- 샤프트 드라이브 4륜 시스템

15101/15103

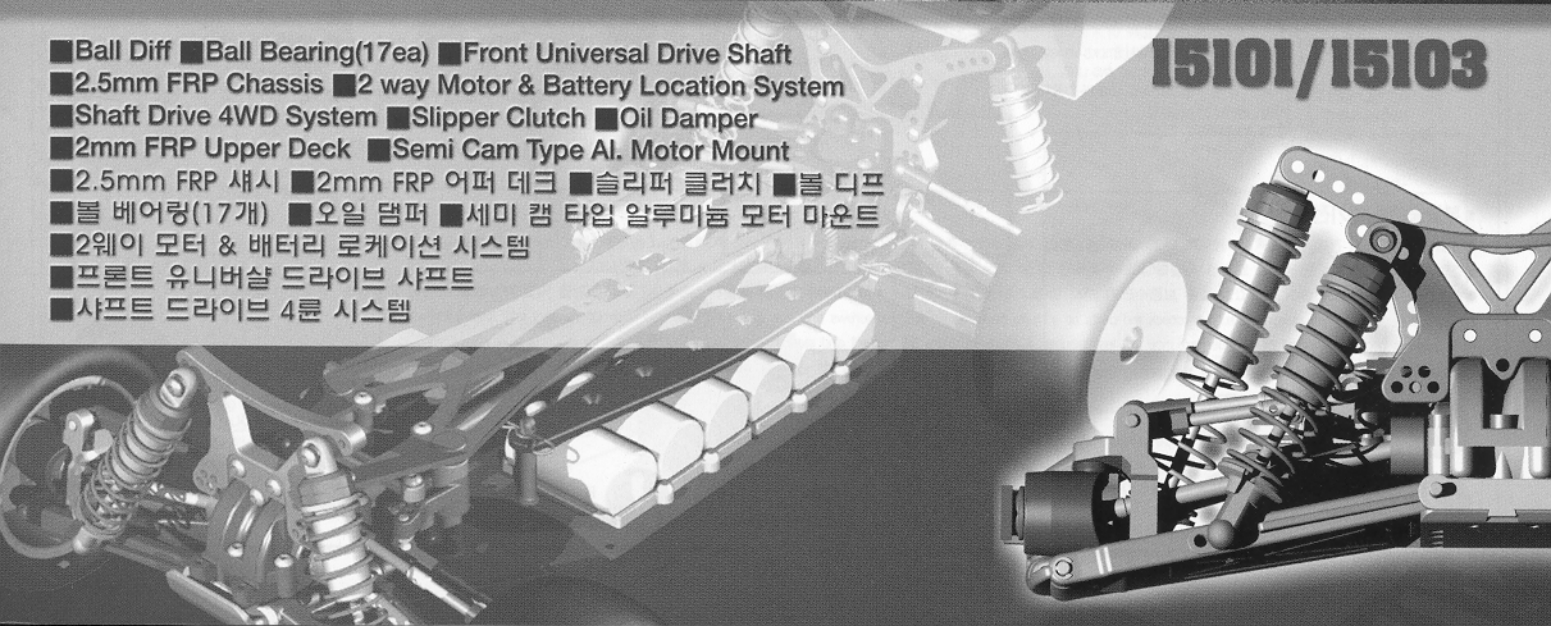

■ RADIO CONTROL UNIT

2채널 송수신기 세트



2 channel Radio Control unit
2채널 송수신기 세트



Battery
송수신기용 배터리
(1.5V 8EA)

This kit is designed for a 2 channel 2 servo digital proportional type of radio control system.

Almost any 2 channel radio can be used. A unit can be used in other model.

본 키트에는 2채널 송수신기 세트를 이용한다. 어느 회사의 것이든 무방하며, 일단 1세트가 준비되면 여러가지 R/C 모형에 응용하여 사용할 수 있다.

■ BUGGY CAR BODY(Included)

버기카 바디(Kit에 포함)



■ 540 TYPE MOTOR

540타입 모터

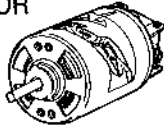

■ Ni-Cd BATTERY

7.2V 충전배터리

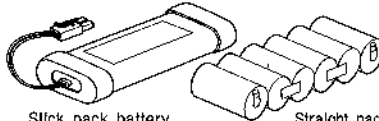

Slick pack battery
스틱팩 배터리

Straight pack battery
스트레이트팩 배터리

It can be recharged more than 300times.
니카드 배터리라고도 하며 충전하여 계속 사용(300회 정도) 할 수 있는 전지를 말한다.

■ ELECTRONIC SPEED CONTROLLER

전자변속기

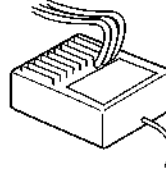

■ CHARGER for Ni-Cd/Ni-MH Battery

Ni-Cd/Ni-MH 배터리 전용 충전기



■ POLYCARBONATE PAINT

색칠에 필요한 재료

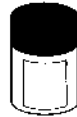

Polycarbonate paint
포리카보네이트 스프레이



Masking tape
마스킹테이프

■ TOOLS

조립에 필요한 공구

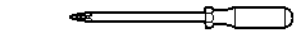

⊕ Screwdriver 드라이버

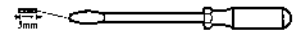

⊖ Screwdriver 드라이버



Long nose plier
리디오벤치

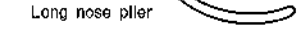

Nipper 니퍼



Scissors 가위



Modelling knife 칼

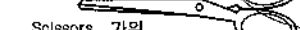

Body reamer 바디 리머



1.5mm
Hex driver 육각드라이버



2mm
Hex driver 육각드라이버



2.5mm
Hex driver 육각드라이버

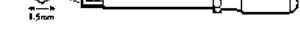

3mm
Hex driver 육각드라이버



3.5mm
Hex driver 육각드라이버

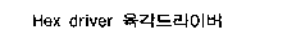

4mm
Hex driver 육각드라이버



4.5mm
Hex driver 육각드라이버



5mm
Hex driver 육각드라이버

■ GLUE 점착제



Instant glue
순간점착제

■ RC EQUIPMENT

송수신기의 동작시절

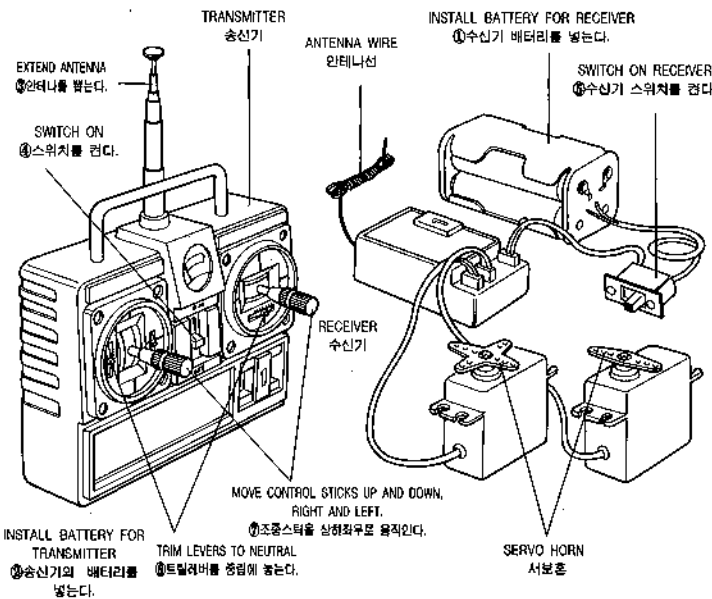

The digital proportional system comprises a transmitter, receiver, servos, etc.

- Transmitter - Serves as a control box. Stick movements are transformed into radio wave signals which are transmitted through antenna.
- Receiver - Receives signal from the transmitter.
- Servos - Servo transforms signals received by the receiver into mechanical movements and actuates the controlled portion of the car.
- Trim Lever - Trim Lever is used to change the direction of the front wheel or to control speed.
- Level Meter - Level Meter shows that batteries for the transmitter are playing out.
- Servo Horn - Servo Horn joints servo with the controlled portion of the car.

2채널 송수신기 세트는 송신기와 수신기, 서어보 및 배터리케이스로 구성되어 있다.

- 송신기 - 조종하는 컨트롤 박스에서 모터의 회전, 키의 좌우 움직임을 안테나를 거쳐 전파로 송신한다.
- 수신기 - 송신기로부터 전파를 받아서 서어보로 보낸다.
- 안테나 - 송신기의 안테나는 전파를 보내고 수신기의 안테나는 전파가 들어오는 중요한 것으로 최대한 길게 사용하는 것이 좋다.
- 트림레버 - 송신기의 트림레버는 서어보의 중심위치를 좌우로 조금씩 움직여 속도조절이나 키의 방향을 수정할 때 사용한다.
- 레벨미터 - 송신기의 전원이 소모된 정도를 나타내는 눈금으로 송수신기의 전원이 약할 경우 잘못된 동작을 하는 경우가 있으니 항상 주의한다.
- 서어보 - 서어보와 차의 컨트롤부를 연결하는 것으로써 여러종류가 있으므로 사용 목적에 맞는 형태를 사용한다.

■ 부품 조립하기 전에

- 구입 후 조립하기 전에는 반드시 부품도와 대조, 확인하고 불량 부품이나 부족한 부품이 있을 경우에는 구입한 직매점이나 A/S센터를 이용하시기 바랍니다.
- 조립을 시작한 후에는 반쯤이나 교합을 사정합니다. ● 작은 비스, 너트 등은 모양이 비슷하므로 설명서를 잘 읽어 본 후 조립한다.
- 송수신기 및 서어보에 물이 들어갔을 경우 보증수리가 되지 않으니 취급에 주의한다. ● 한 가지씩 조립을 확실하게 해나가는 것이 고장을 막고 제성능을 충분히 발휘하는 좋은 R/C 모델이 된다.
- Before assembling a kit, please be sure to check the parts up with its parts list. ● Small screws and nuts look alike and read instructions very well before assembling.
- To make a good R/C model of high-performance but less trouble, it needs to make the correct and steady assembling step by step.

* Do not use excessive force when tightening the tapping screws and bolts. 볼트 및 비스를 톰 때 너무 무리하게 힘을 가하지 않는다.

Cut away 잘라낸다	Use allen key, ⊕wrench. L자 또는 ⊕자렌치를 사용하여 조립한다.	Repeat operation 수 만큼 조립한다	Repeat for opposite side 반대쪽도 조립한다.	Grease Apply grease to the place. 그리스를 바른다
Optional parts 선택한다	Make hole 구멍을 뚫어준다.	Be careful 주의한다.	Glue Apply instant glue to the place. 순간점착제를 바른다	

- 2.5 Ball diff. screw 2
볼디프스크류
- 2.5 Ball diff. nut 2
볼디프너트
- 850 Oilless metal 4
오일레스메탈 베어링

Tuning part

- 850 Ball bearing 4
볼베어링

- 2.6x6 Thrust washer 4
스라스트와셔

- Ball diff. spring 2
볼디프스프링

- ø 2.5 Diff. ball 24
디프볼

- ø 2 Thrust ball 12
스라스트볼

- Ball diff. washer 4
볼디프와셔



P.I. Clutch disk
클러치디스크



Slipper shaft
슬리퍼샤프트

- Slipper spring 1
슬리퍼스프링

- Slipper nut 1
슬리퍼너트

- ø 2x9.8 Pin 2
핀

- 1510 Oilless metal 1
오일레스메탈 베어링

- 6x10 Washer 1
와셔

- 1510 Ball bearing 1
볼베어링

- 1050 Ball bearing 2
볼베어링

1 A (Ball diff.)

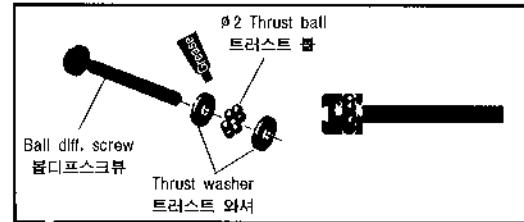

Ball diff. screw
볼디프스크류

Thrust washer
트라스트 와셔

ø 2 Thrust ball
트라스트 볼

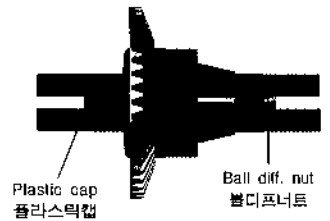

Plastic cap
플라스틱캡

Ball diff. nut
볼디프너트

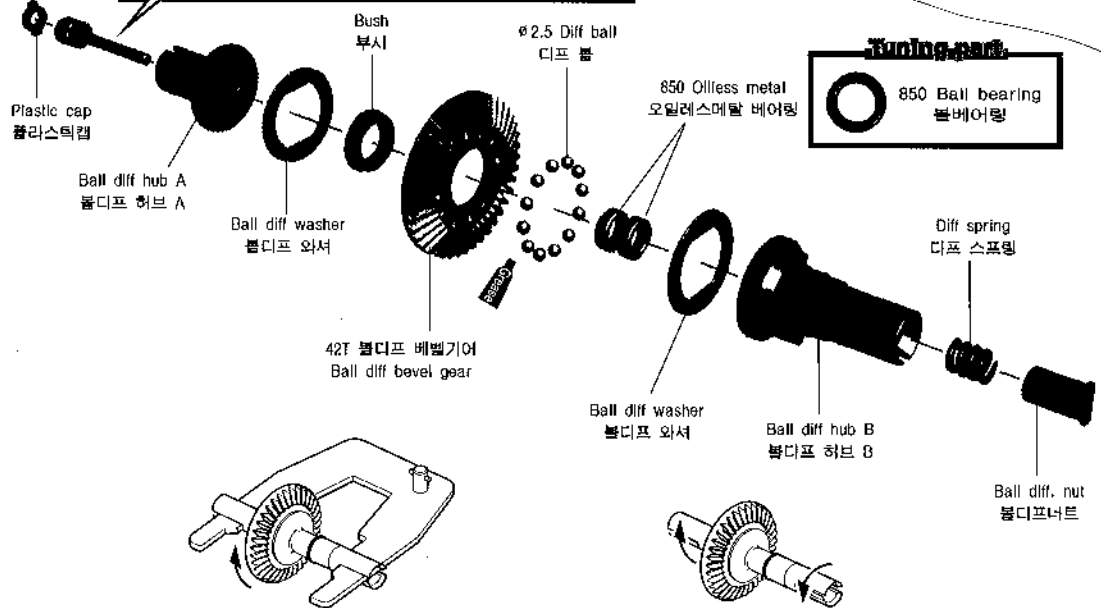

Plastic cap
플라스틱캡

Ball diff hub A
볼디프 허브 A

Ball diff washer
볼디프 와셔

Bush
부시

ø 2.5 Diff ball
디프 볼

850 Oilless metal
오일레스메탈 베어링

42T 볼디프 베벨기어
Ball diff bevel gear

Ball diff washer
볼디프 와셔

Ball diff hub B
볼디프 허브 B

Diff spring
디프 스프링

Ball diff. nut
볼디프너트



850 Ball bearing
볼베어링

그림과 같이 양쪽의 디프허브를 고정시키고 디프기어가 슬립하지 않을 정도까지 볼디프스크류를 죄어본다. 너무 세게 죄지 말 것. 무리하게 죄면 디프와셔가 파손될 수 있다.

As shown in picture, holding both of diff joint cups, tighten ball diff screw as much as it does not slip. Do not tighten too much, or diff washer can be damaged.

디프기어는 그림과 같이 부드럽게 움직이도록 조립한다. 볼디프스크류를 너무 세게 죄지 않도록 주의.

The differential should spin smoothly after they are assembled. Take care not to tighten ball diff screw too much.

2 B (Slipper clutch)

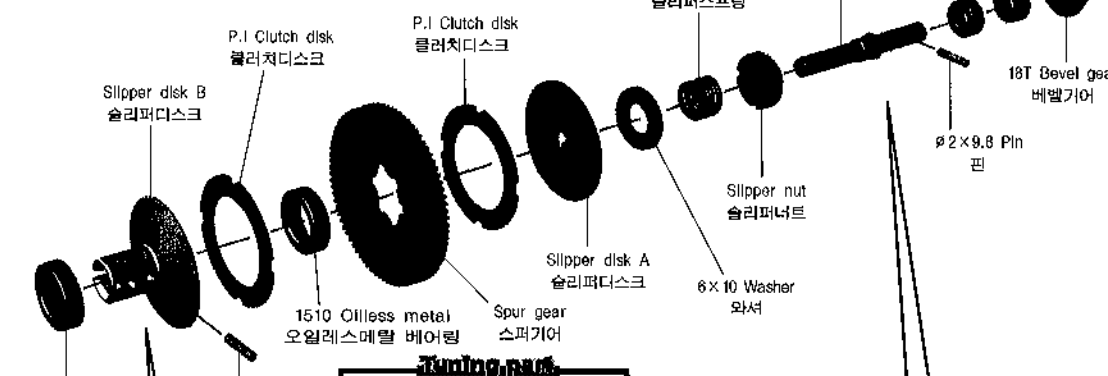

P.I. Clutch disk
클러치디스크

P.I. Clutch disk
클러치디스크

Slipper disk B
슬리퍼디스크

Slipper spring
슬리퍼스프링

Slipper shaft
슬리퍼샤프트

1050 Ball bearing
볼베어링

18T Bevel gear
베벨기어

ø 2x9.8 Pin
핀

Slipper nut
슬리퍼너트

6x10 Washer
와셔

Slipper disk A
슬리퍼디스크

1510 Oilless metal
오일레스메탈 베어링

Spur gear
스퍼기어

1510 Ball bearing
볼베어링

ø 2x9.8 Pin
핀

1510 Ball bearing
볼베어링

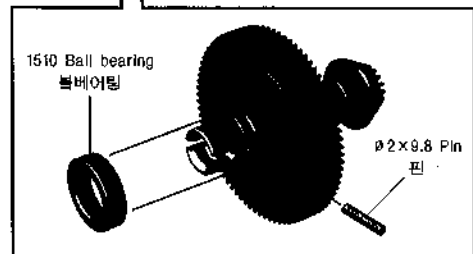

1510 Ball bearing
볼베어링

ø 2x9.8 Pin
핀

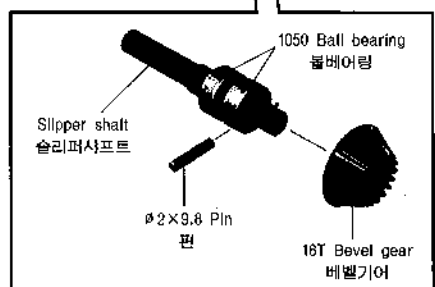

Slipper shaft
슬리퍼샤프트

1050 Ball bearing
볼베어링

ø 2x9.8 Pin
핀

18T Bevel gear
베벨기어

③ C (Front gear box) 2.5mm

 3 x 10 RH wrench screw
RH 렌치볼트 5

 ø2x9.8 Pin
핀 2

 1510 Ball bearing
볼베어링 2

 1050 Ball bearing
볼베어링 2

 10x13x0.2t Washer
와셔 3

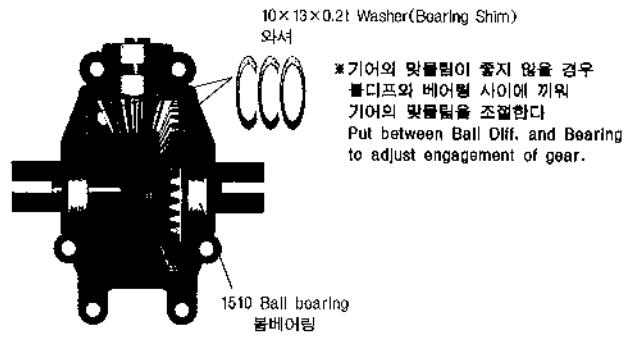
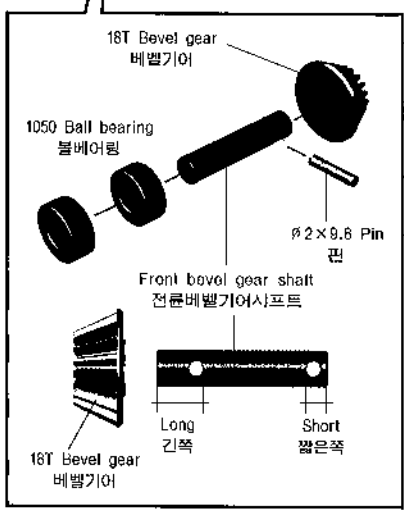
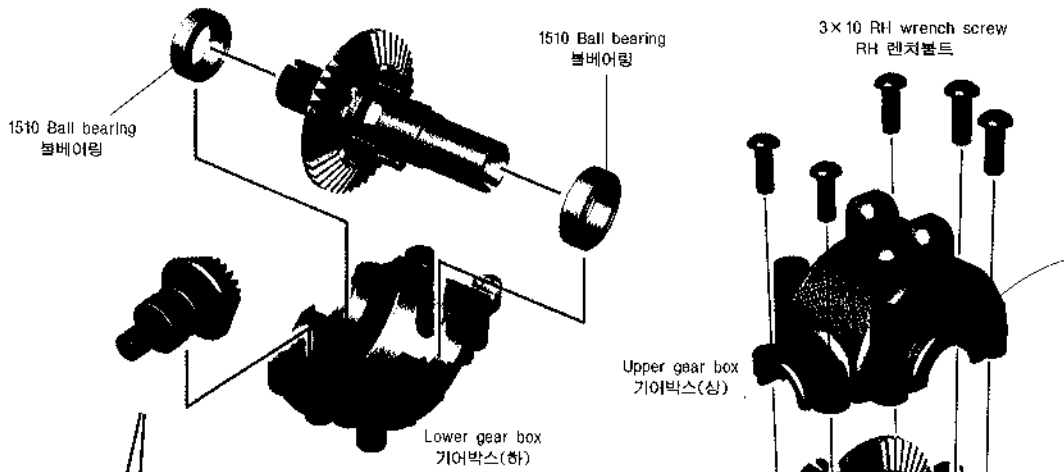

④ C (Rear gear box) 2.5mm

 3 x 10 RH wrench screw
RH 렌치볼트 5

 1510 Ball bearing
볼베어링 2

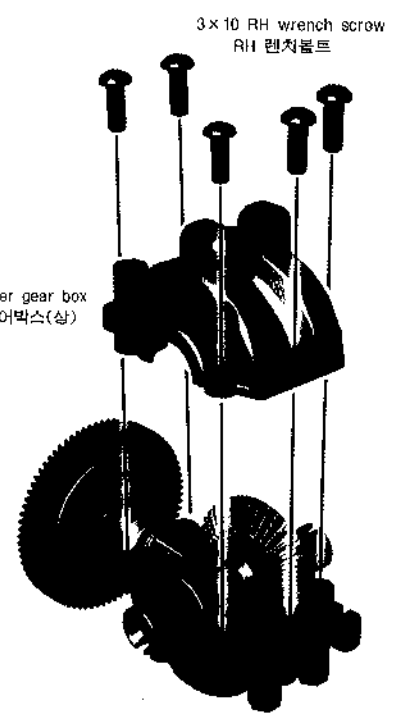
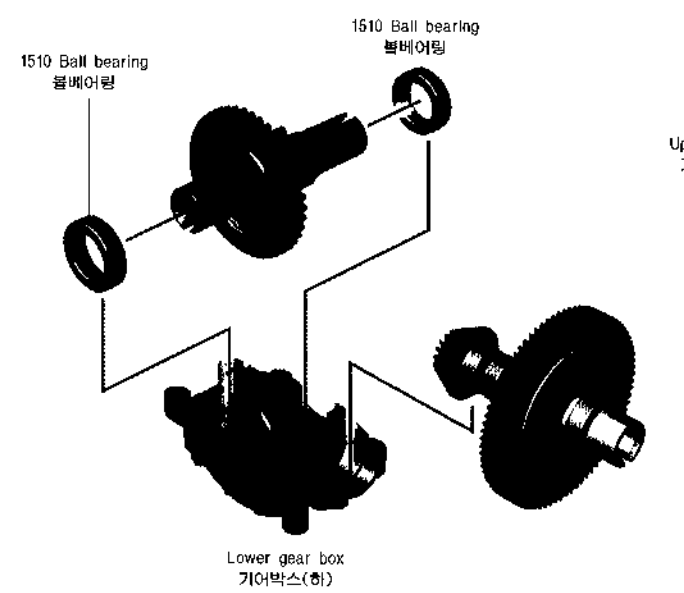

SBV2

1/10 SCALE EP 4WD BUGGY

ø5×8×0.2t Washer

와셔

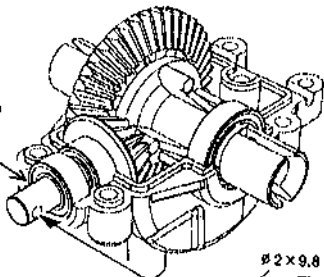

ø2×9.8 Pin

핀



ø5×8×0.2t Washer

와셔

Joint cup
조인트컵

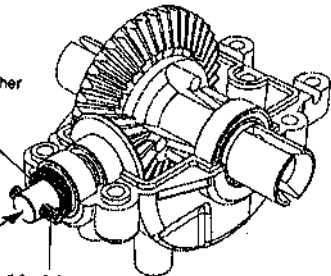
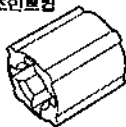

ø2×9.8 Pin

핀

⑤ D 



3x8 FH Wrench screw 3
FH 렌치볼트



ø3 Nut 3
너트

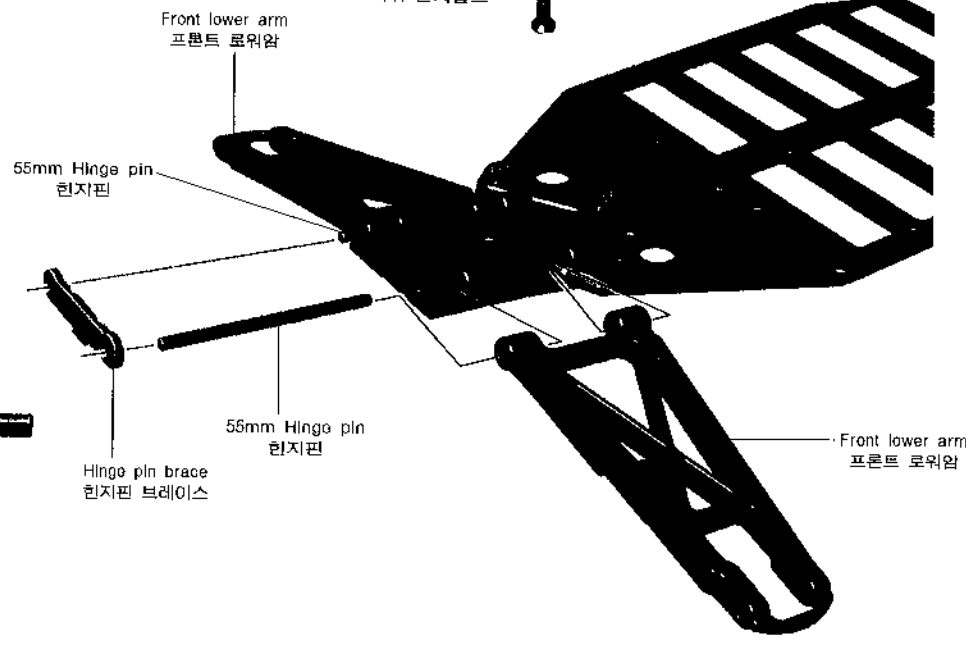
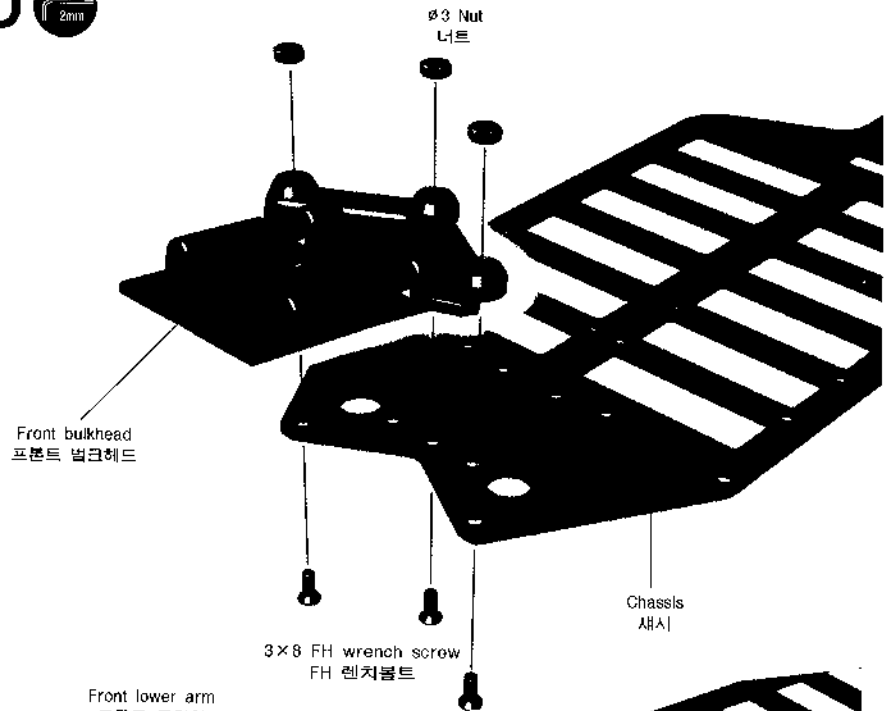

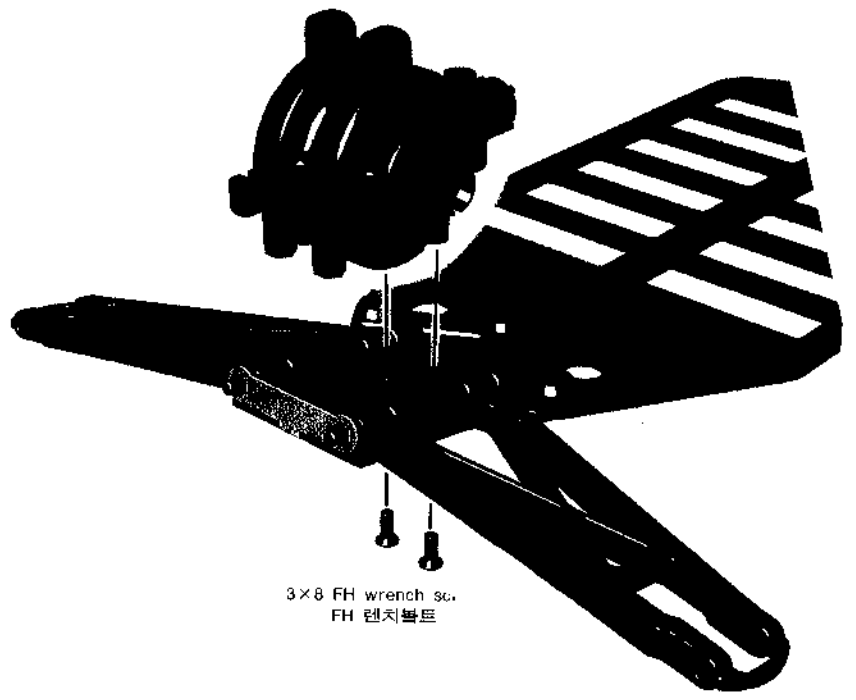

55mm Hinge pin 2
힌지핀



3x8 FH Wrench screw 2
FH 렌치볼트

6 D 

 3x6 FH Wrench screw 2
FH 렌치볼트

 3x10 FH Wrench screw 2
FH 렌치볼트

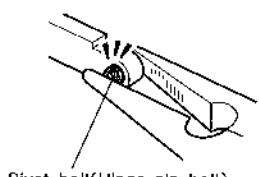

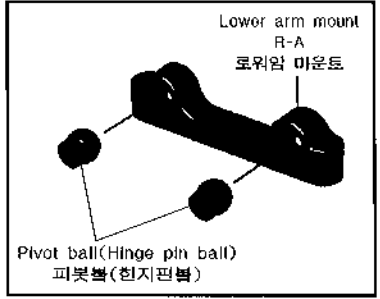
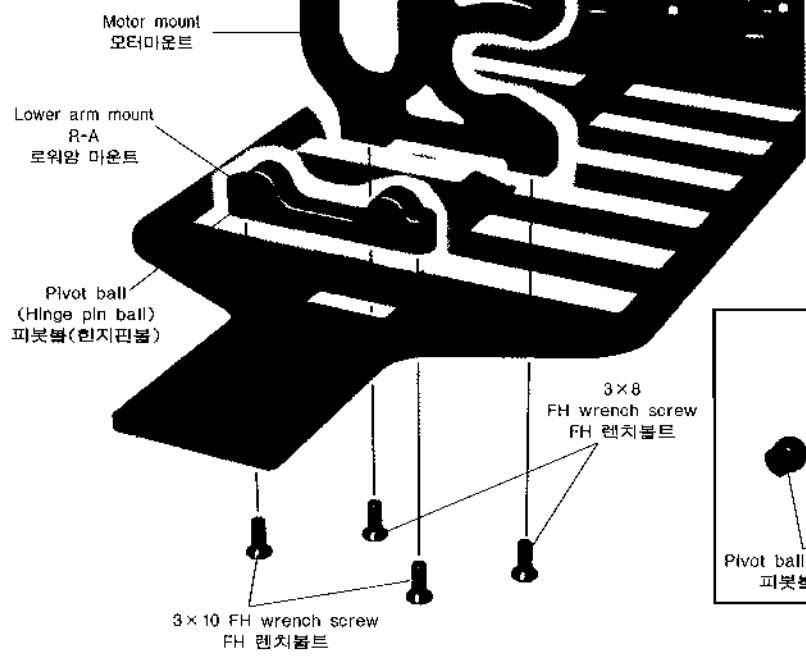

Pivot ball(Hinge pin ball)
피봇볼(힌지핀볼)

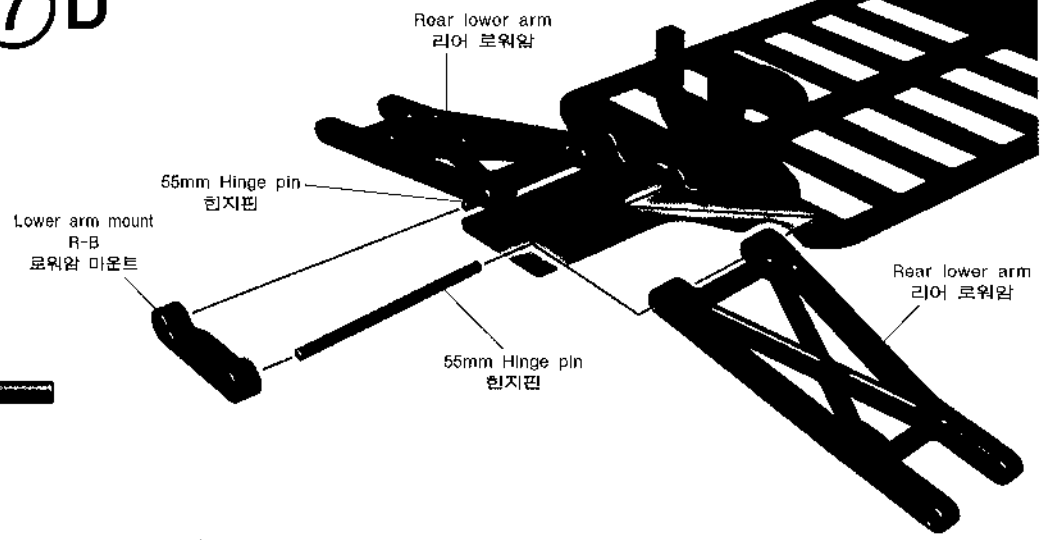
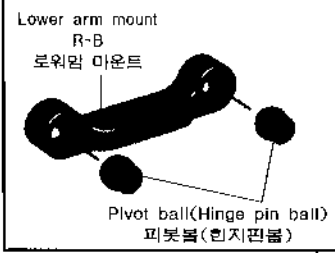

7 D



 55mm Hinge pin 2
힌지핀

 3x8 FH Wrench screw 2
FH 렌치볼트

 3x12 FH Wrench screw 2
FH 렌치볼트

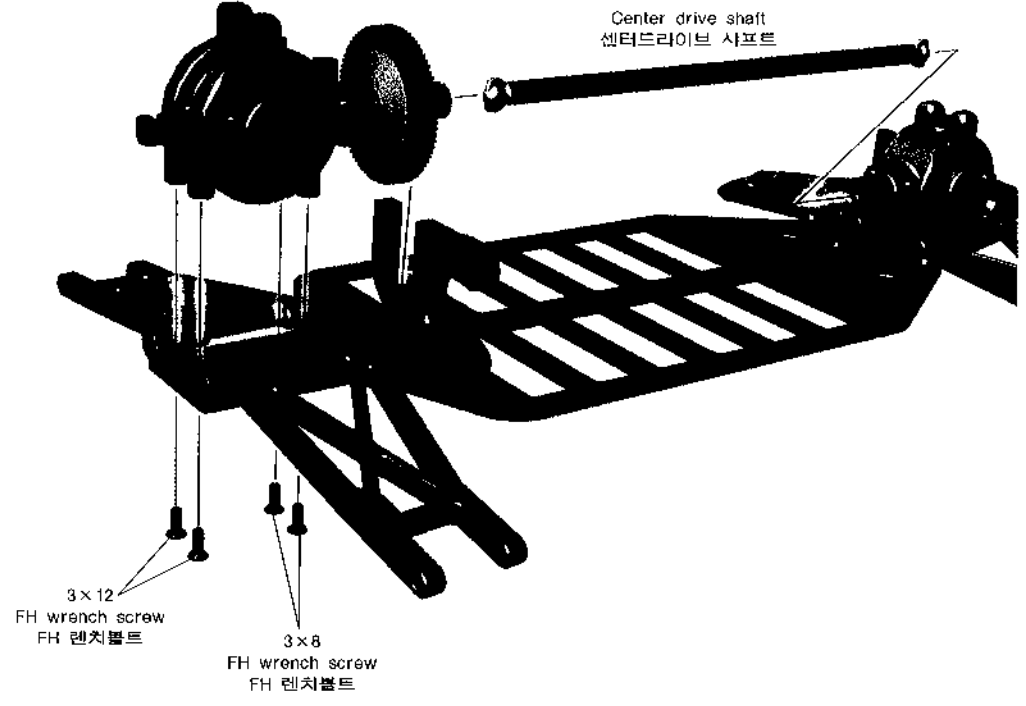
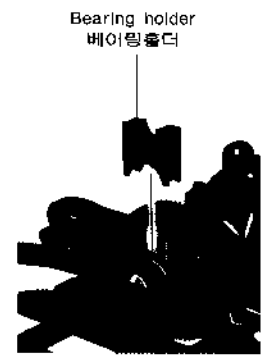

8 E

ø4.3 Ball end A 볼엔드

44mm Rod 로드



A



B

50mm Rod 로드

C

50mm Rod 로드

D

50mm Rod 로드

Steering rink 스티어링링크

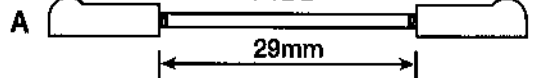

Front upper rod 프론트어퍼로드

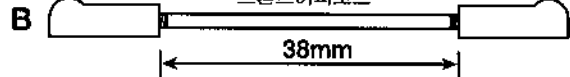

Rear upper rod(Right) 리어어퍼로드(오른쪽)

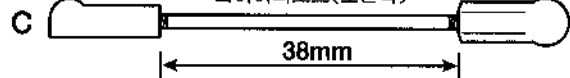

38mm

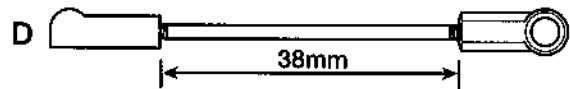

Tuning part

VXB-T003 ø4.3 Ball end A 볼엔드

VXB-T003 42mm Turnbuckle 턴버클 2

VXB-T003 52mm Turnbuckle 턴버클 4

ø4.3 Ball end A 볼엔드

42mm Turnbuckle 턴버클



A



B

52mm Turnbuckle 턴버클

C

52mm Turnbuckle 턴버클

Steering rink 스티어링링크

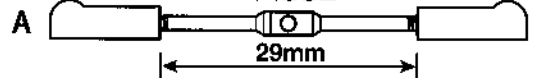

Front upper rod 프론트어퍼로드

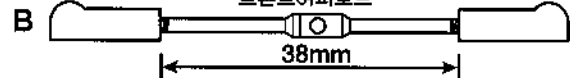

Rear upper rod(Right) 리어어퍼로드(오른쪽)

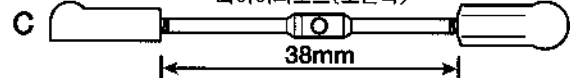

38mm

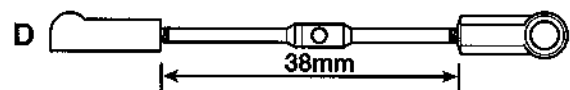

Tuning part

TRT-3
840 Ball bearing 4
볼베어링

840 Oilless metal 2
오일리스 메탈

∅4.3 Pin ball 3
핀볼

Saver spring adjuster 1
세이버스프링어저스터

Saver spring 1
세이버스프링

Steering post A 1
스티어링포스트

Steering post B 1
스티어링포스트

6x10 Washer 1
와셔

3x6 Bush 2
부시

Upper deck post 2
어퍼데크포스트

3x8 FH Wrench screw 2
FH 렌치볼트

∅5 E-Ring 1
E-링

3x10 RH wrench screw 2
RH 렌치볼트

9 E  

840 Oilless metal
오일리스 메탈

Tuning part
TRT-3
840 Ball bearing
볼베어링

∅4.3 Pin ball
핀볼

Tuning part
TRT-3
840 Ball bearing
볼베어링

3x10 RH wrench screw
RH 렌치볼트

3x6 Bush
부시

A

Bearing holder
베어링홀더

Bearing holder
베어링홀더

Steering post A
스티어링포스트

Servo saver B
서보세이버

Servo saver C
서보세이버

6x10 Washer
와셔

Saver spring
세이버스프링

840 Oilless metal
오일리스 메탈

840 Oilless metal
오일리스 메탈

Tuning part
TRT-3
840 Ball bearing
볼베어링

Steering post B
스티어링포스트

Servo saver spacer
서보세이버 스페이스

Servo saver A
서보세이버

∅5 E-Ring
E-링

840 Oilless metal
오일리스 메탈

Tuning part
TRT-3
840 Ball bearing
볼베어링

Upper deck post
어퍼데크 포스트

3x8 FH wrench screw
FH 렌치볼트

A

Bearing holder
베어링홀더



3x8 RH wrench screw 4
RH 렌치볼트



3x10 RH wrench screw 4
RH 렌치볼트

10 F

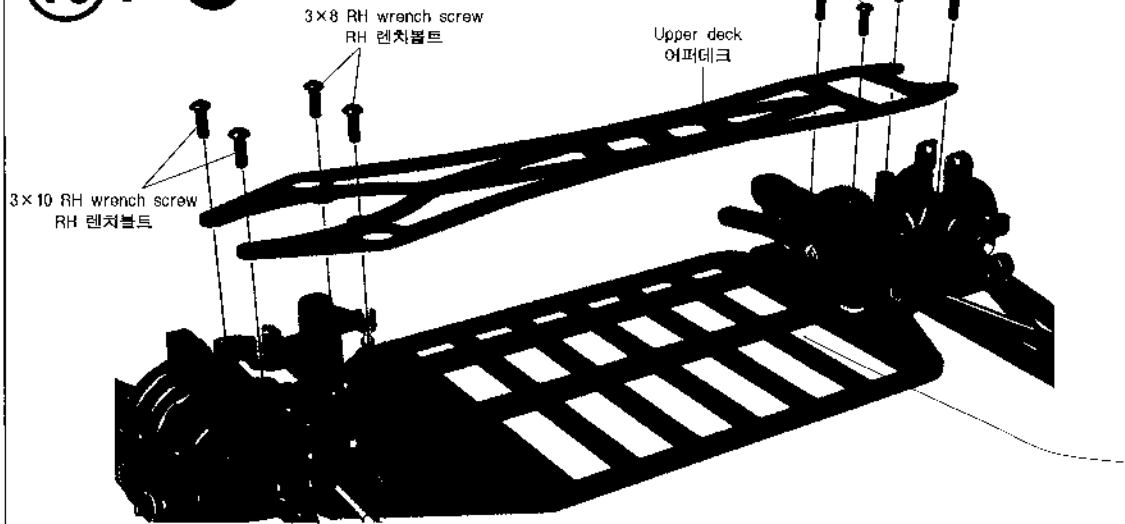

11 F



Front damper stay
프론트 댐퍼스테이



Forward
앞쪽

Backward
뒷쪽



3x10 RH wrench screw 7
RH 렌치볼트



3x14 RH wrench screw 4
RH 렌치볼트



ø4.3 Pin ball 4
핀볼



3x8 Washer 4
와셔

3x10
RH wrench screw
RH 렌치볼트

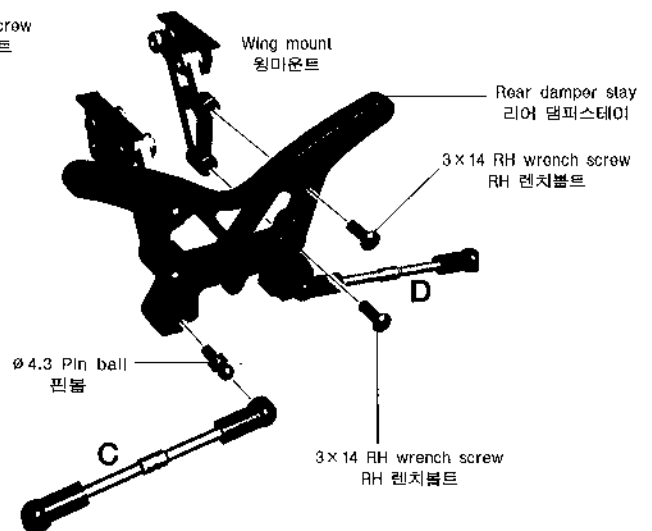
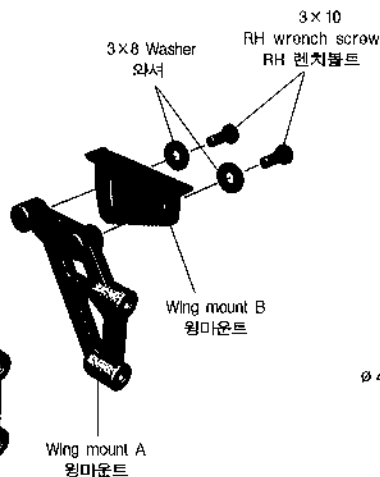
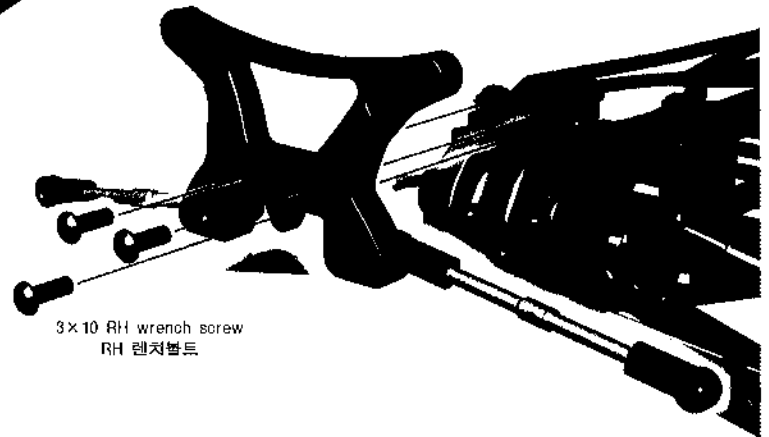
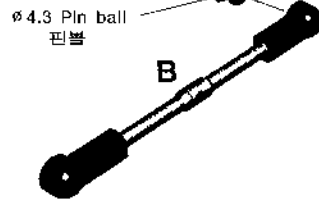
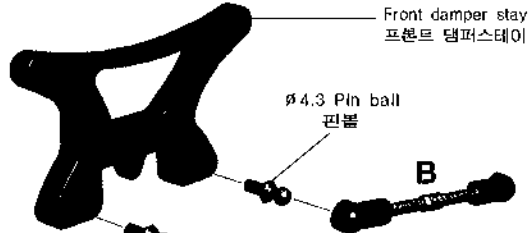
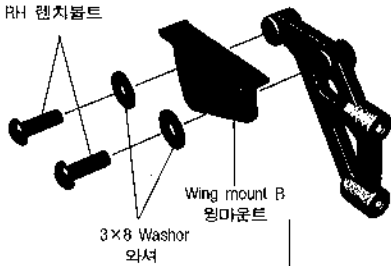



3x10 RH wrench screw 3
RH 렌치볼트

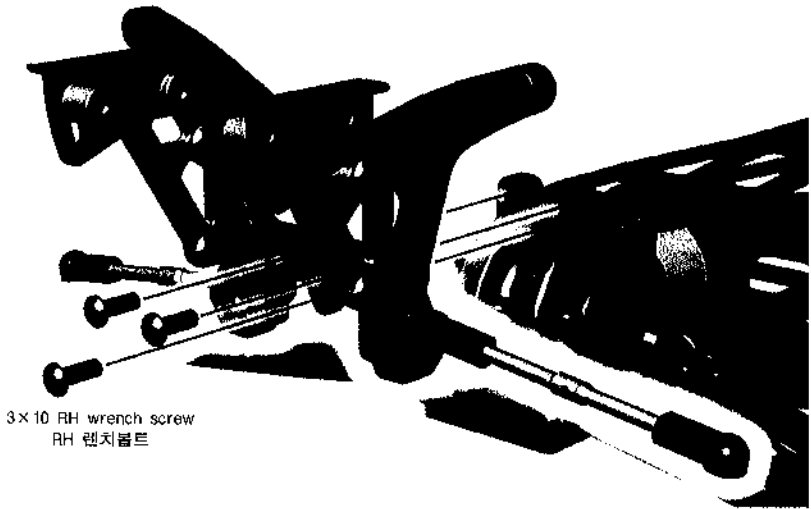

3x10 RH wrench screw
RH 렌치볼트

12 F 

Battery protector guard
배터리 프로텍터 가아드

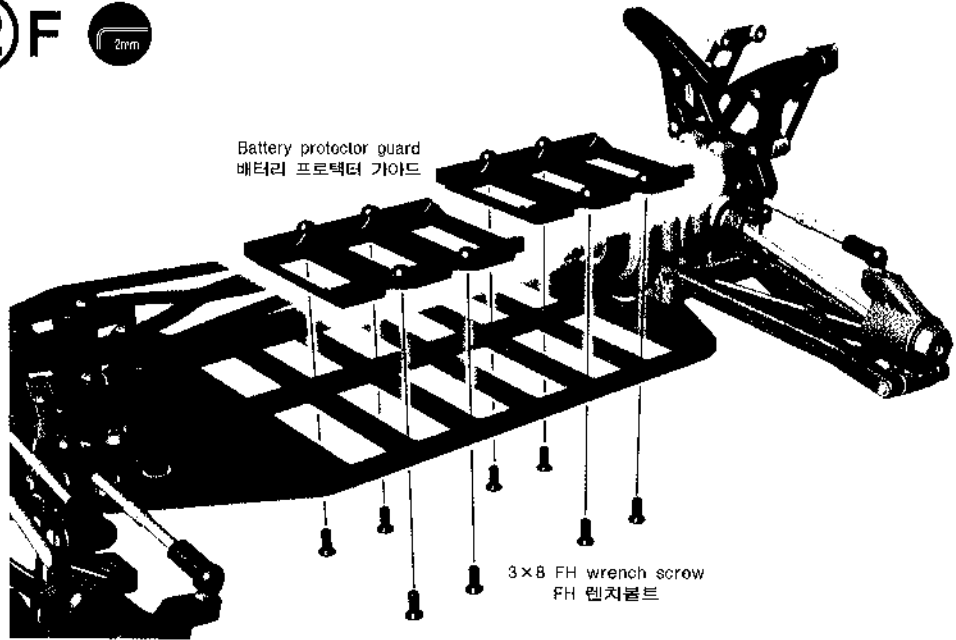

3x8 FH wrench screw
FH 렌치볼트



3x8 FH Wrench screw 10
FH 렌치볼트



Battery strap post
배터리 스트랩 포스트



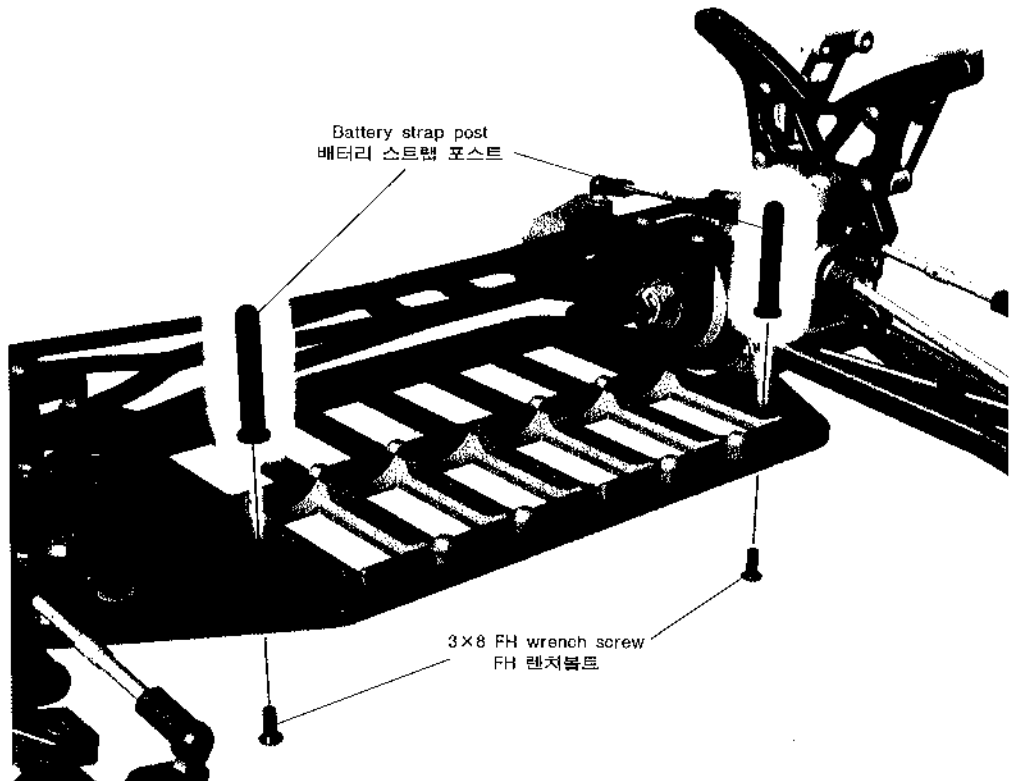

Battery strap post 2
배터리 스트랩 포스트



3x8 FH wrench screw
FH 렌치볼트

13 G    **2**

 2x11 Joint pin 2
조인트핀

 4.5x6.5 Joint pin 2
조인트핀

 3x2.5 Set screw 2
육각렌치볼트

 U-Axle shaft 2
유니버설 액셀샤프트

 U-Wheel hub 2
유니버설 휠허브

 1510 Ball bearing 4
볼베어링

 10x13x0.21 Washer 2
와셔

 ø 4.3 Pin ball 4
핀볼

 Step bolt(King pin) 4
스텝볼트(킹핀)

 26.5mm Hinge pin 2
힌지핀

 ø 2 E-Ring 4
E-링



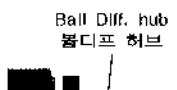

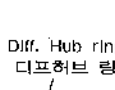
 Diff. Hub ring 2
디프허브 링

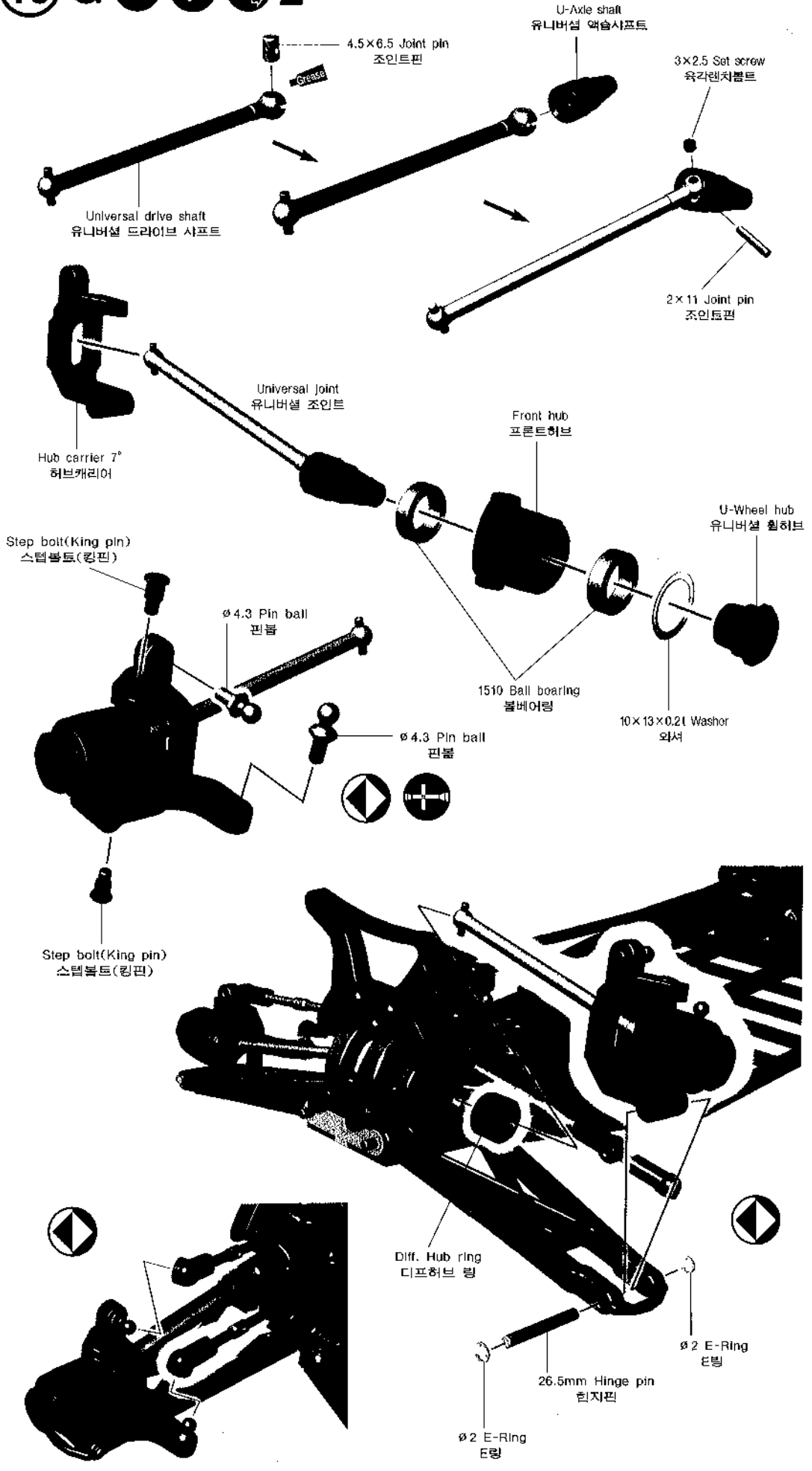
 Ball Diff. hub
볼디프 허브





 Diff. Hub ring
디프허브 링



14 G    2

-  $\phi 3$ Nylon nut 나일론너트 2
-  $\phi 4.3$ Pin ball 핀볼 2
-  Joint ring 조인트 링 2
-  1510 Ball bearing 볼베어링 4
-  Wheel hub 휠허브 2

Tuning part

-  2x11 Joint pin 조인트핀 4
-  4.5x6.5 Joint pin 조인트핀 4
-  3x2.5 Set screw 육각렌치볼트 4
-  U-Wheel hub 유니버설휠허브 2
-  U-Axle shaft 유니버설 액셀샤프트 2

-  Diff. Hub ring 디프허브 링 2
-  Axle shaft spring 액셀샤프트스프링 2
-  $\phi 2$ E-Ring E-링 4
-  33mm Hinge pin 힌지핀 2

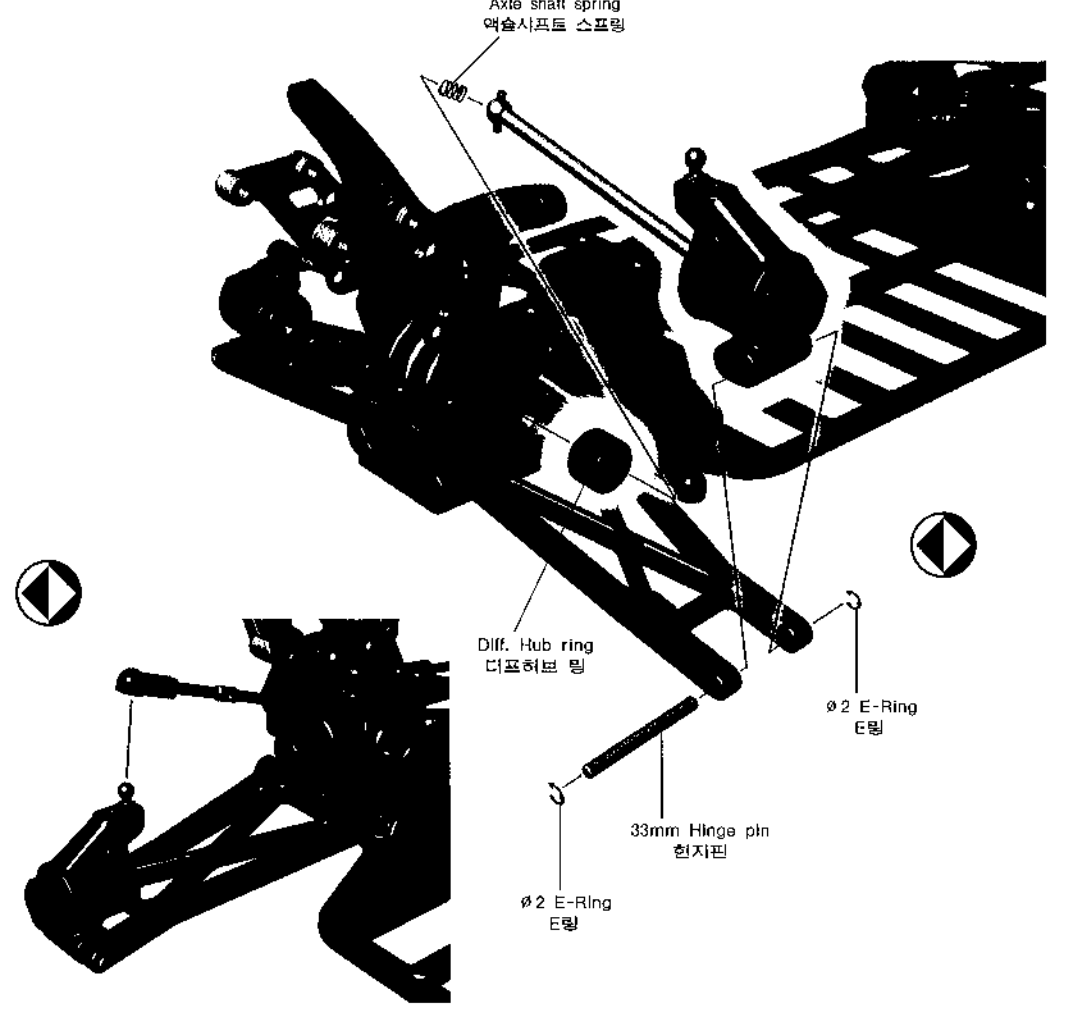
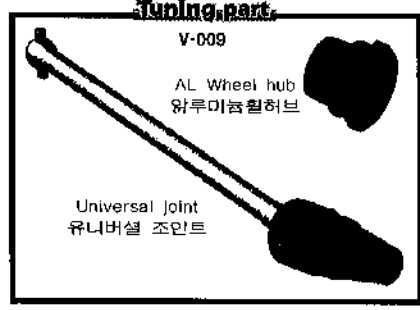
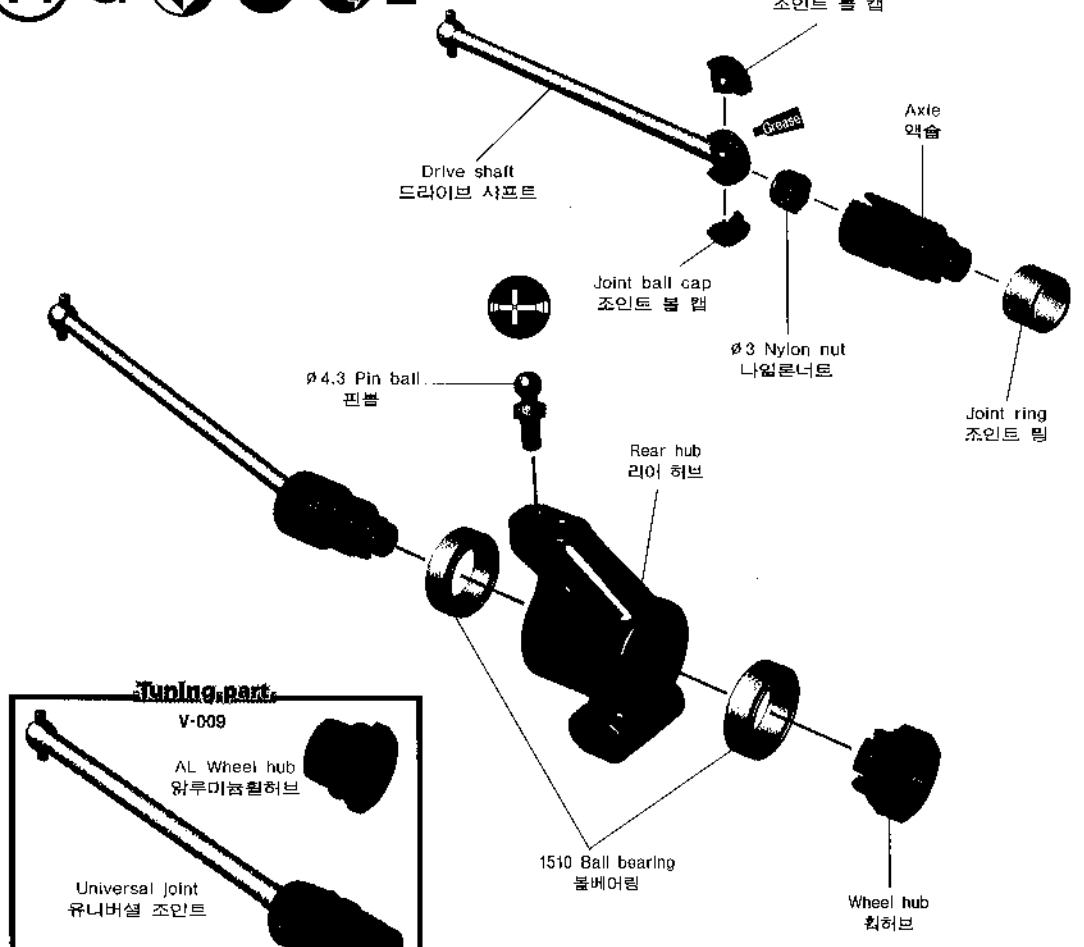

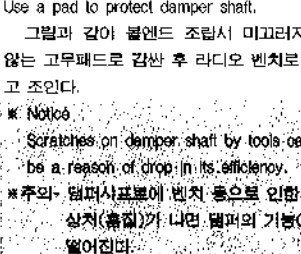
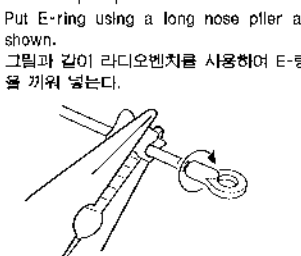
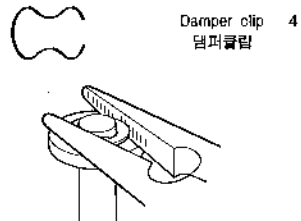
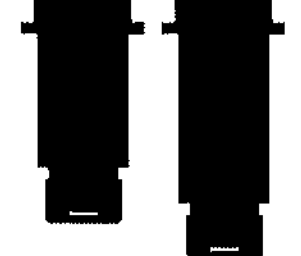
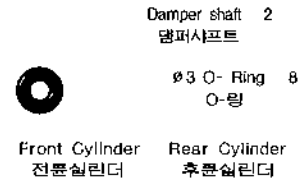
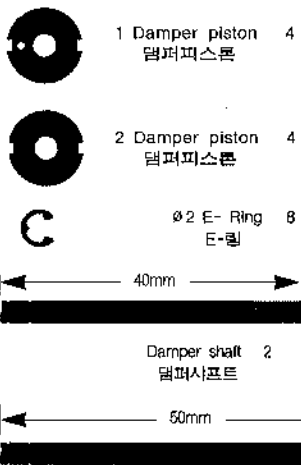

Damper Exploded View <댐퍼분해도>

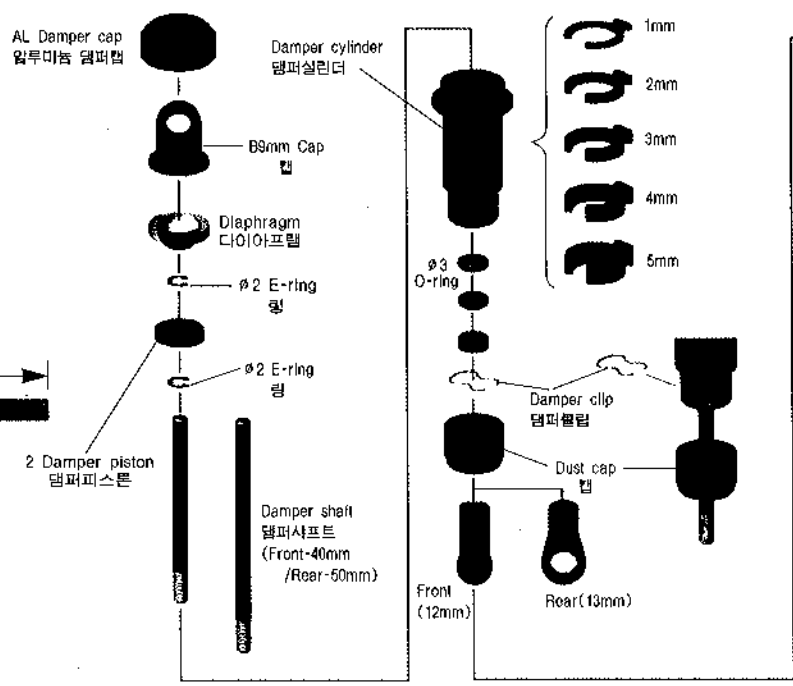

15H 4

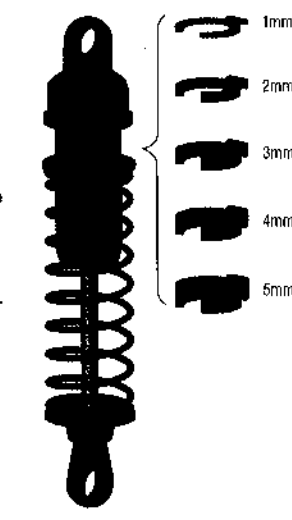
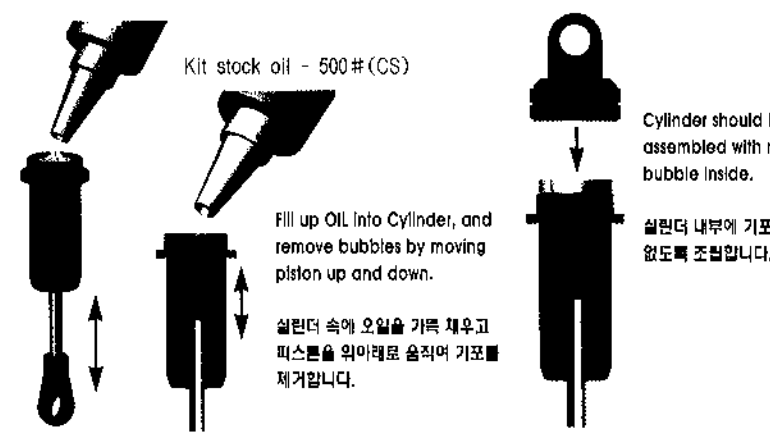

Tuning part

Damper Exploded View <댐퍼분해도>

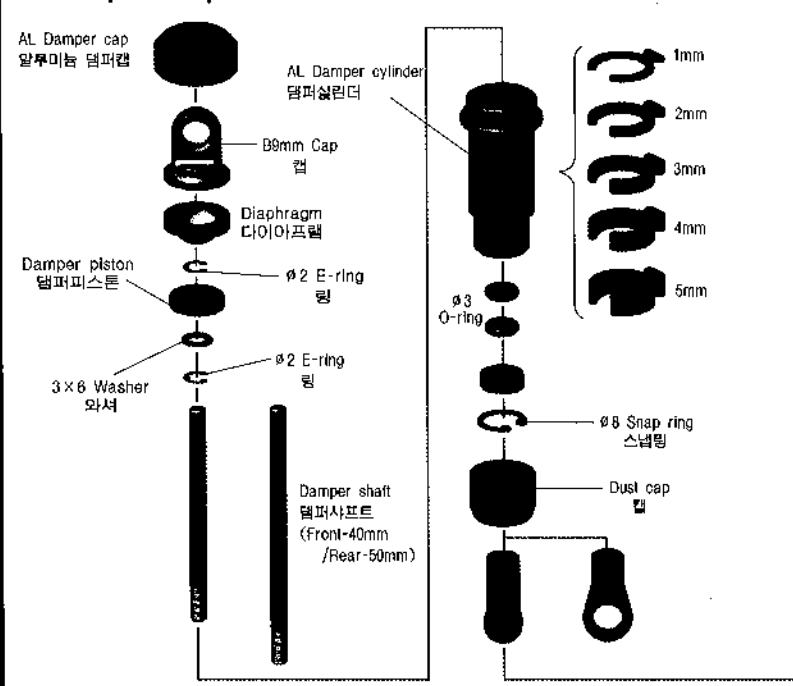

VXB-T004 (for Front)
RG-T001 (for Rear)

16 H  

 $\varnothing 4.3$ Pin ball 2
핀볼

 3 x 14 RH wrench screw 4
RH 렌치볼트

 $\varnothing 5.8$ ball 2
볼

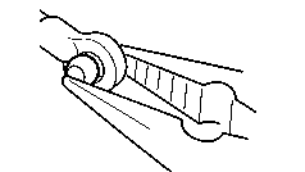
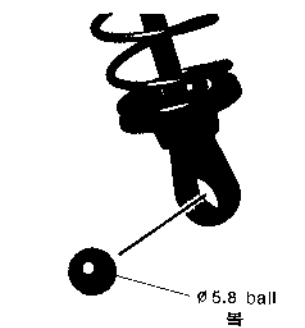

 3 x 12 RH wrench screw 4
RH 렌치볼트

 FH Washer 2
와셔

 3 x 12 FH Wrench screw 2
FH 렌치볼트

 3 x 2.5 Set screw 4
육각렌치볼트

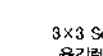
 3 x 3 Set screw
육각렌치볼트

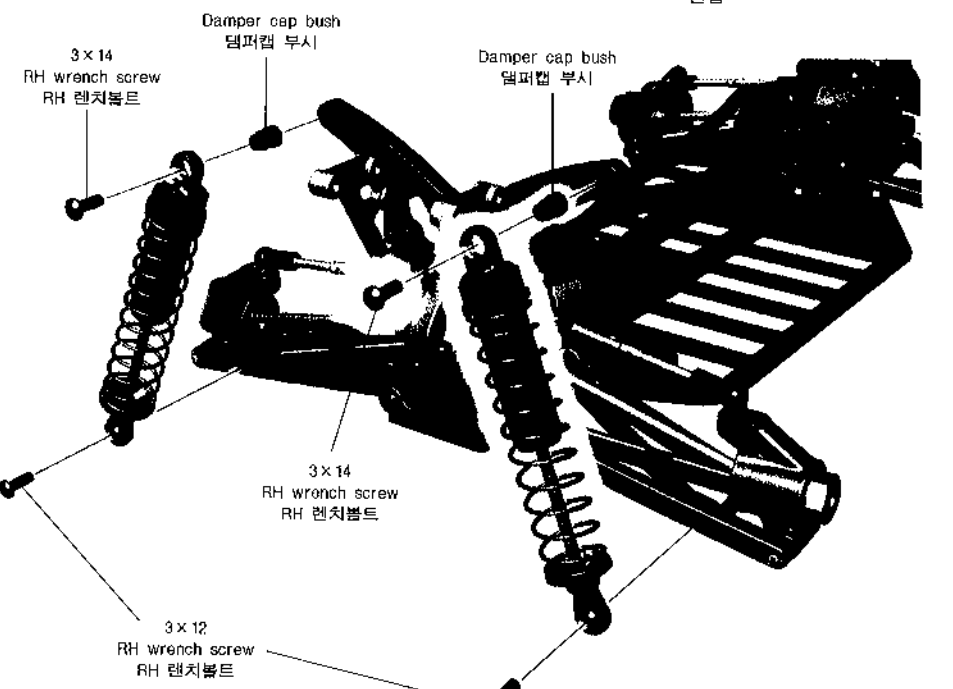
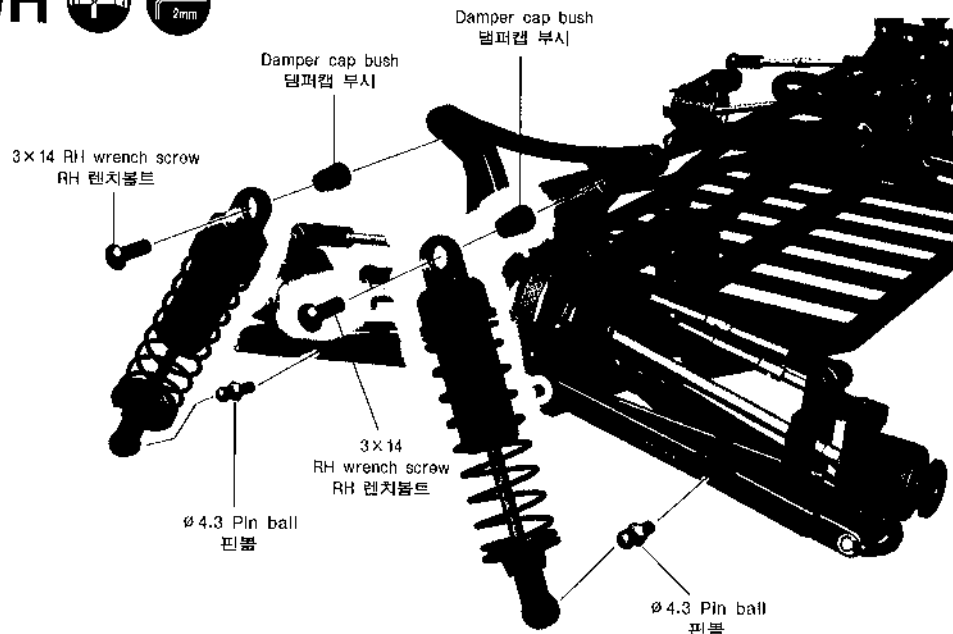
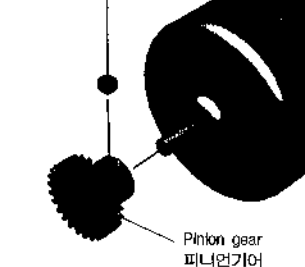

17 I  

3 x 12 FH Wrench screw
FH 렌치볼트

FH Washer
FH와셔

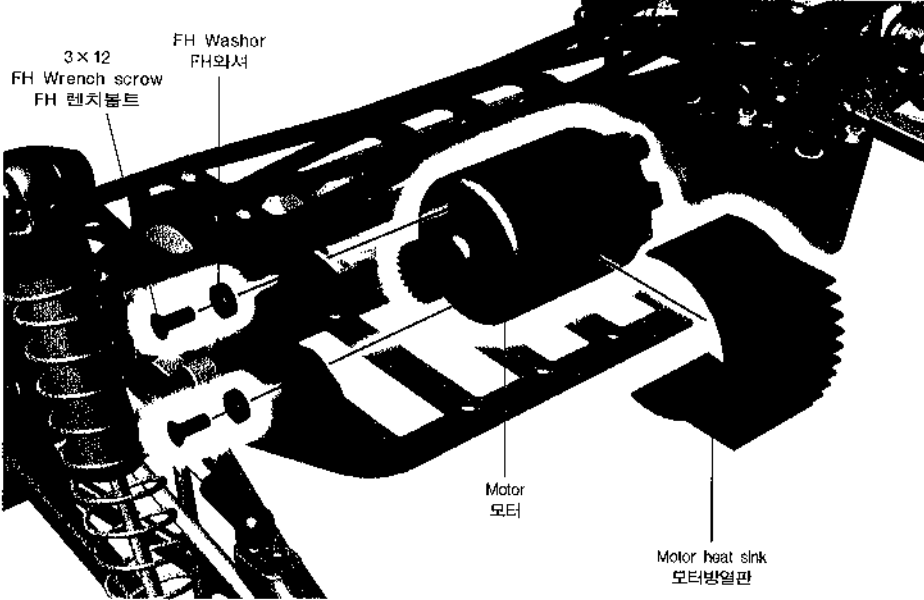

18

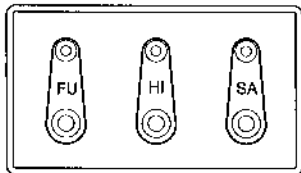

FUTABA 후디바 HIITEC 하이텍 SANWA 산와



FH Washer 2
와셔



3x10 FH Wrench screw 3
FH 렌치볼트



ø 4.3 Pin ball 2
핀볼



3x10 Rod 1
로드



2.6x10 BH screw 1
스크류
(for Metal gear servo)



2.6x10 BH₂ Tapping screw 1
비스
(for Standard servo)

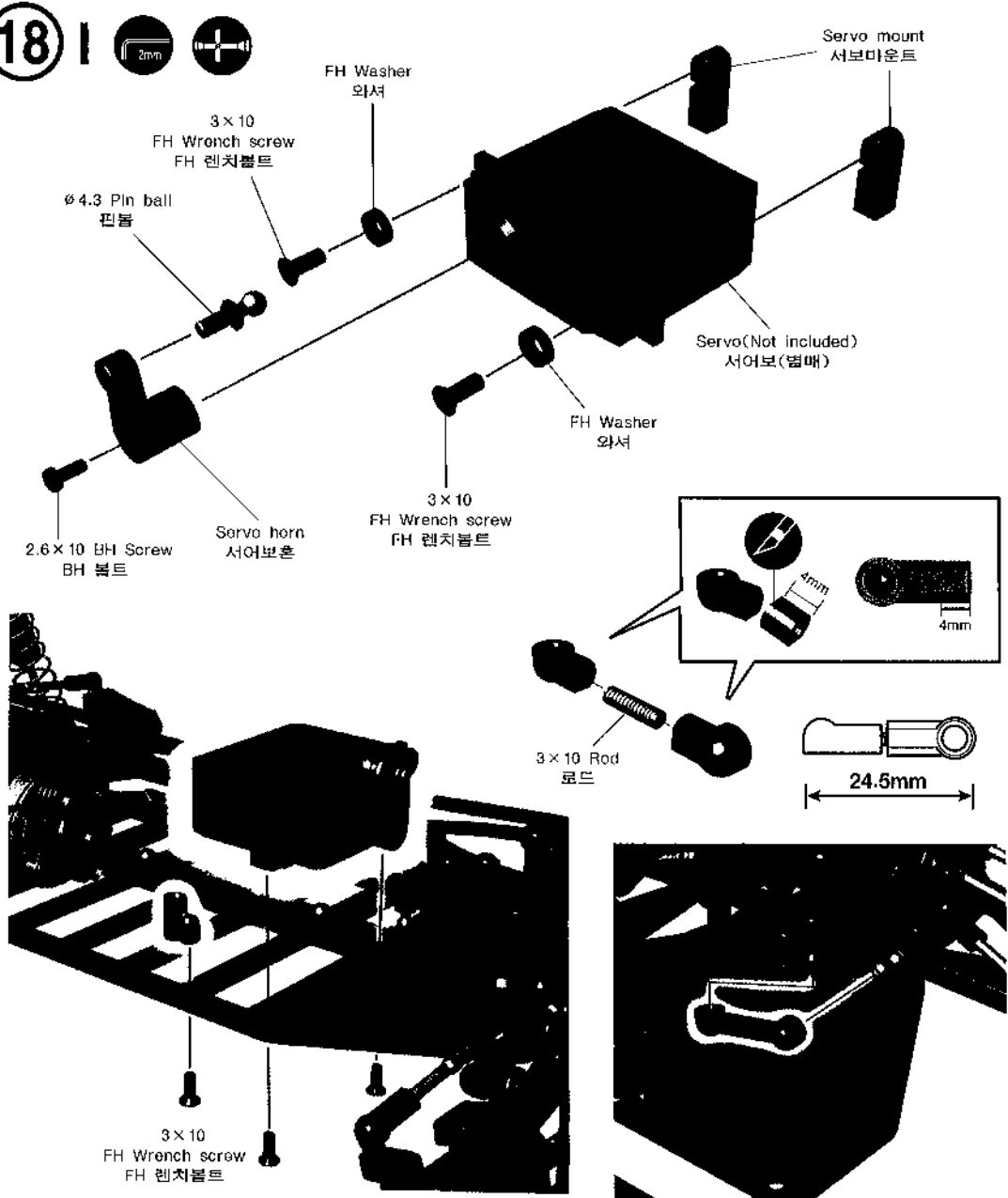

19

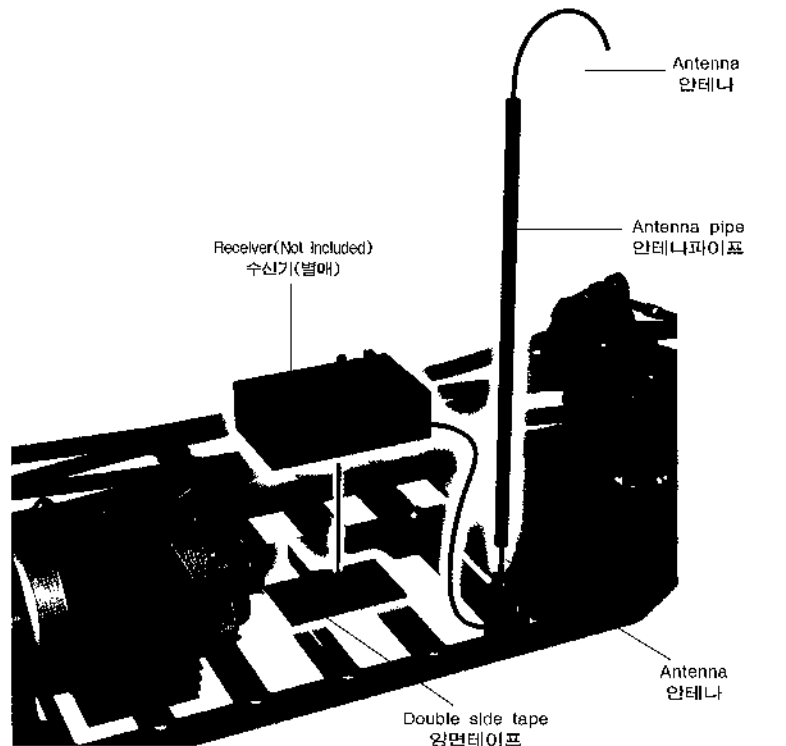
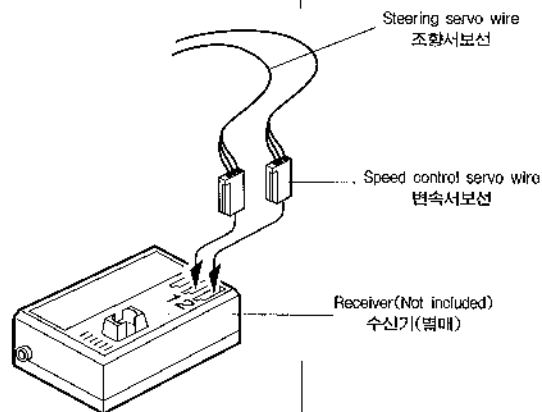

20 I

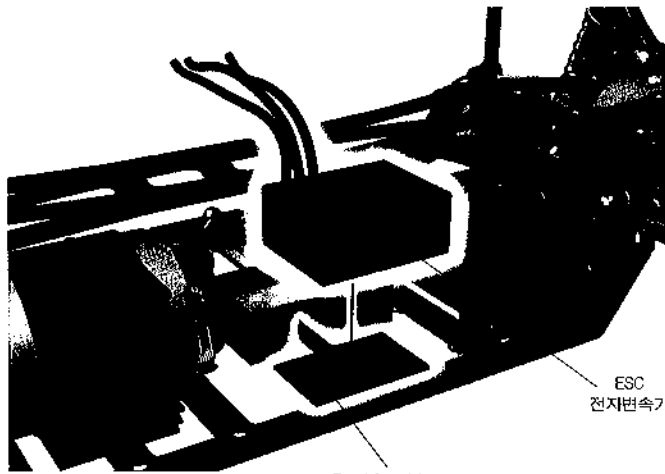
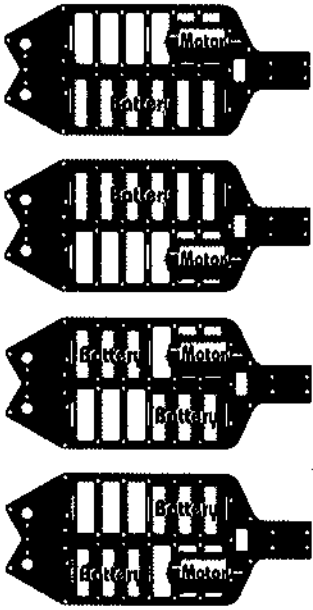

ESC
전자변속기

Double side tape
양면테이프



Battery strap
배터리스트랩

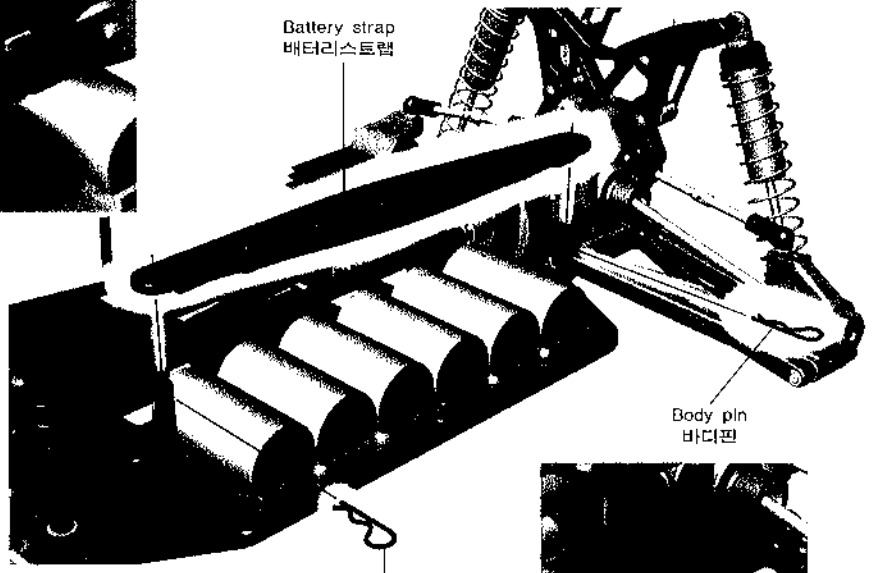

Body pin
바디핀

Body pin
바디핀



Body pin 2
바디핀

21 I

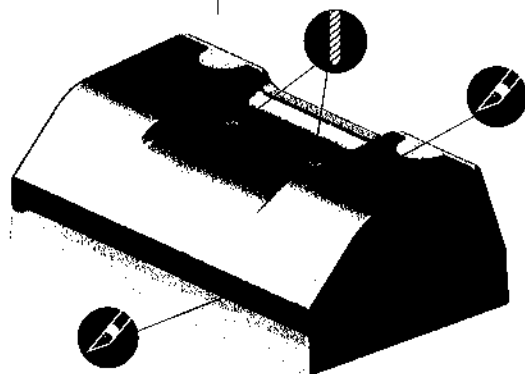

3 x 10 FH wrench screw
FH 렌치볼트

Wing mount washer
윙마운트 와셔

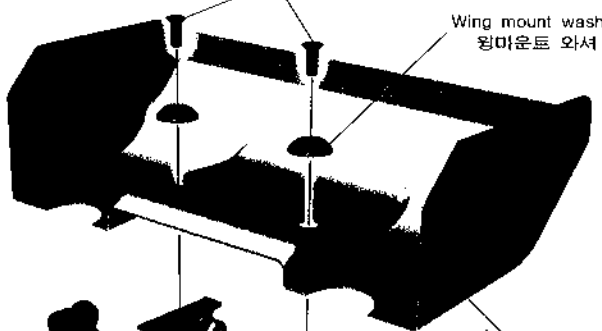

Wing
윙

3 x 10 FH Wrench screw 2
FH 렌치볼트

Wing mount washer 2
윙마운트 와셔

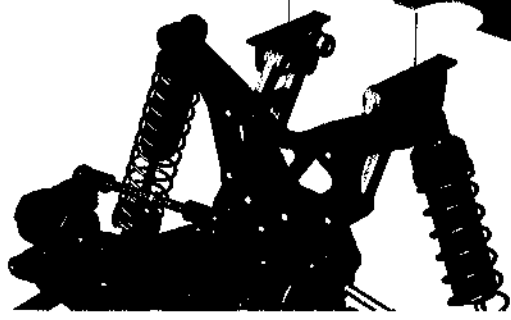

22 |

■ NOTICE (참고)

Attach the decals as you want.

스티커는 상지그림을 참조하여 임의대로 붙인다.

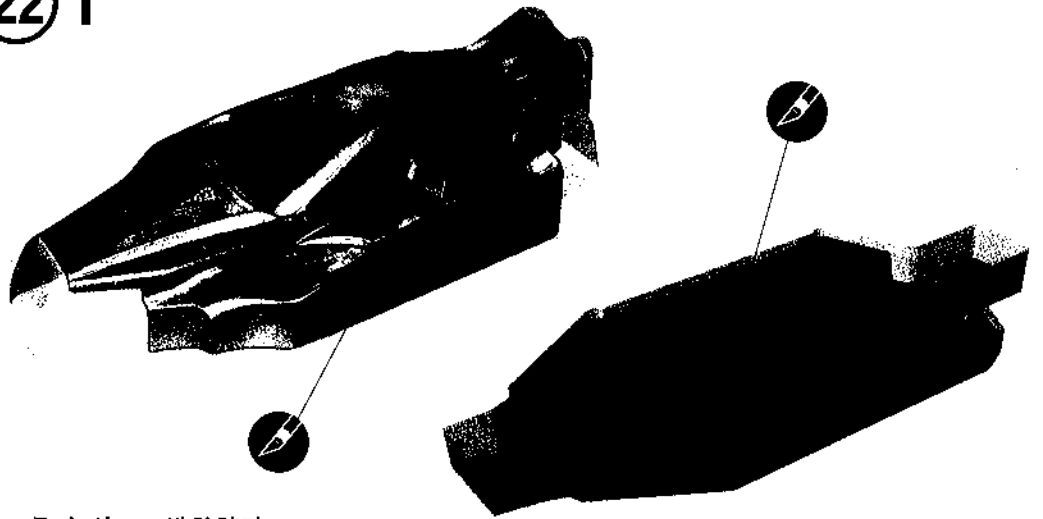

■ Painting 색칠하기

- 1) Before painting, wash inside with neutral detergent. 색칠전에 중성세제로 내부를 씻어 준다.
- 2) Apply polycarbonate painting after masking off windows. 창문에 마스킹을 한 후 폴리카보네이트 페인트를 칠해 준다.
- 3) When paintings are dried out, peel off masking and protective films. 색칠이 마르면 마스킹과 보호 필름을 벗겨 낸다.

3 × 12 FH Wrench screw 2
FH 렌치볼트

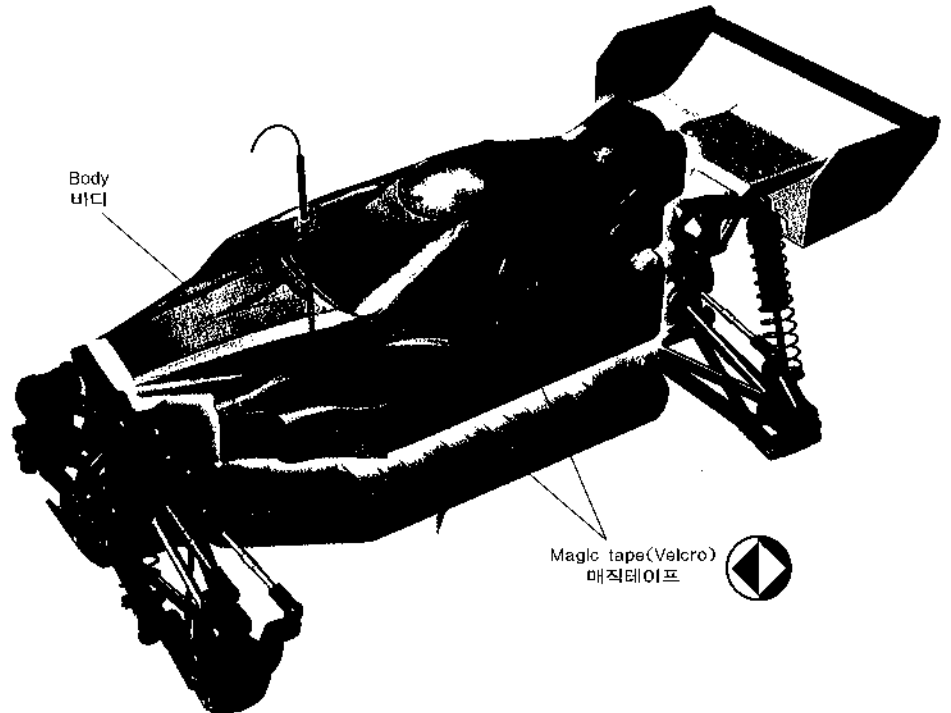
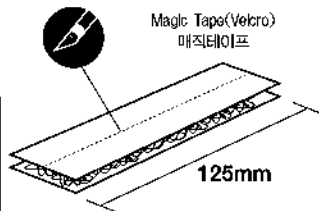
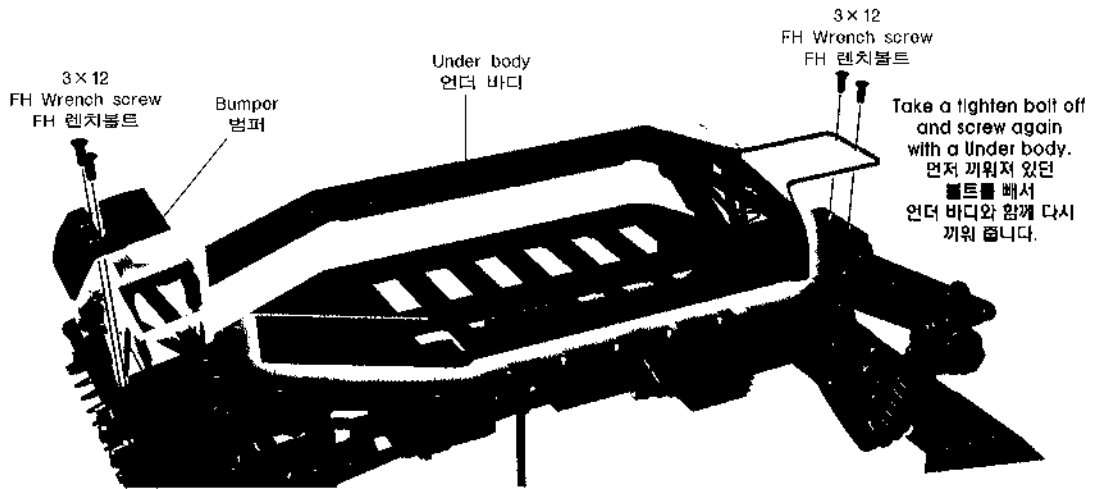



Front wheel
프론트휠



Rear wheel
리어휠



Front tire
프론트타이어



Rear tire
리어타이어

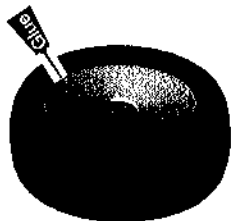

3×18 Cap screw 4
캡스크류



Wheel lock washer 4
휠락 와셔

23 J 2.5mm

Inner foam(Front-Narrow)
인너스폰지(전륜-좁은것)

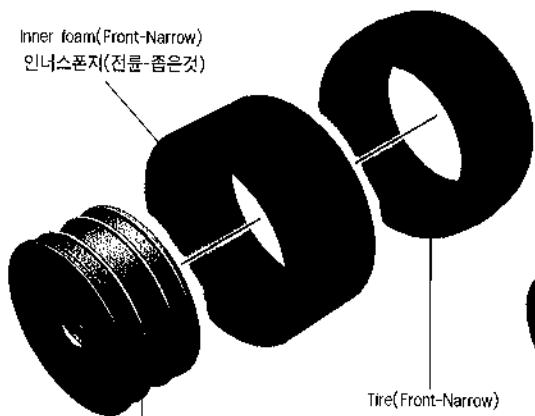

Wheel(Front-Narrow)
휠(전륜-좁은것)

Tire(Front-Narrow)
타이어(전륜-좁은것)

Inner foam(Rear-Wide)
인너스폰지(후륜-넓은것)

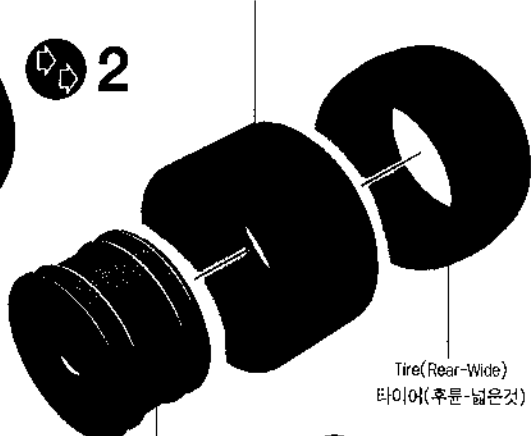

Wheel(Rear-Wide)
휠(후륜-넓은것)

Tire(Rear-Wide)
타이어(후륜-넓은것)

Front 전륜

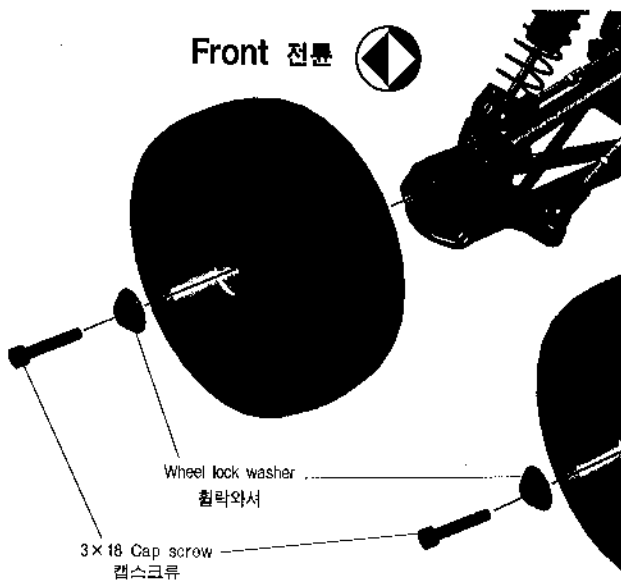

3×18 Cap screw
캡스크류

Wheel lock washer
휠락와셔

Rear 후륜

Adjustment of Slipper Clutch

슬리퍼 클러치의 조절

Slipper & Damper cap wrench
슬리퍼 및 댐퍼캡 렌치

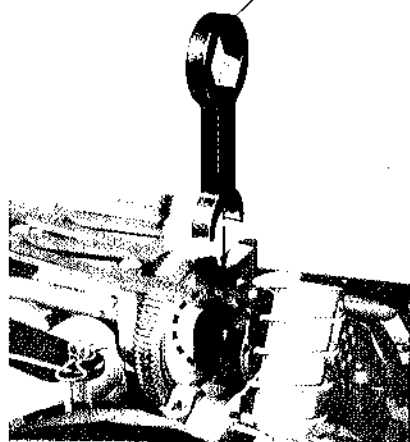

Lock-Hard
(Hi Grip Track)
잠김(하드)

Unlock-Soft
(Low Grip Track)
풀림(소프트)

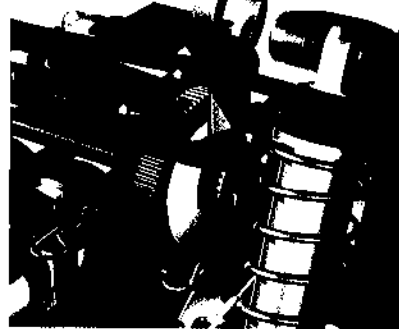

Mount Slipper Clutch on your machine as shown in the drawing and do the test driving.

- A. In case of slower start of acceleration and continuous slipping noise of slipper in driving, fasten slipper towards LOCK to use of Slipper wrench.
- B. In case of good start of acceleration but unstable driving and spinning at the time of acceleration, unfasten slipper towards UNLOCK to use of Slipper wrench.

※ Through repeating above A & B steps, arrive at the optimal setting.

차량에 슬리퍼클러치 그림과 같이 장착후 주행해 본다.

- A. 가속이 느리고 주행 중 슬리퍼의 미끄럼 소리가 계속되면, 슬리퍼를 슬리퍼렌치를 이용하여 조여준다. (잠김방향)
- B. 가속은 좋으나 차량이 안정되지 않고 가속에 소란현상이 발생하면, 슬리퍼를 슬리퍼렌치를 이용하여 풀어 준다. (풀림방향)

※A와 B의 과정을 반복 주행하여 최상의 Setting을 이끌어 낸다.

SB V2 Packing List

PACKING	SB V2 BUGGY
SB-A	<p>42T 베벨기어×2, 디프러브A×2, 디프러브B×2, 볼디퍼와셔×4, 850오일레스메탈×4, 베벨부시×2, 시슬릿×2, ϕ2.5 볼×24, ϕ2볼×12, 드리스트와셔×4, 볼디퍼스크류×2, 볼디퍼너트×2, 실버볼디퍼×2, 실리온 그리스×1</p> <p>42T Bevel gearX2, Diff. hub(A)X2, Diff. hub(B)X2, Ball diff. washerX4, 850 Oilless metalX4, Bevel bushX2, Injection capX2, ϕ2.5 BallX24, ϕ2 BallX12, Thrust washerX4, Ball diff. screwX2, Ball diff. nutX2, Silver ball diff.X2, Silicon greaseX1</p>
SB-B	<p>70T 스퍼기어×1, 72T 스퍼기어×1, 74T 스퍼기어×1, 78T 스퍼기어×1, 80T 스퍼기어×1, 1510 오일레스메탈×1, 2×9.8 핀×2, 1050 볼베어링×2, 1510 볼베어링×1, 리볼러치디스크×2, 슬리퍼디스크B×1, 슬리퍼샤프트×1, 슬리퍼디스크A×1, 슬리퍼어저스터너트×1, 슬리퍼스프링×1, 18T 베벨×1, 스퍼스페이서×6</p> <p>70T Spur gearX1, 72T Spur gearX1, 74T Spur gearX1, 78T Spur gearX1, 80T Spur gearX1, 1510 Oilless metalX1, 2X9.8 PinX2, 1050 Ball bearingX2, 1510 Ball bearingX1, Pl Clutch diskX2, Slipper disk BX1, Slipper shaftX1, Slipper disk AX1, Slipper adjust nutX1, Slipper springX1, 18T BevelX1, Spur spacerX6</p>
SB-C	<p>기어박스(상)×2, 기어박스(하)×2, 10×13×0.2t 와셔×6, 1050볼베어링×2, 1510볼베어링×4, 3×10캡스크류×10, 프론트베벨샤프트×1, 2×9.8 핀×2, 18T 베벨(소)×1, 센터조인트립×2, ϕ1.5 L렌치×1, ϕ2 L렌치×1, ϕ2.5 L렌치×1, 십자렌치×1, 시슬렌치×1</p> <p>Gear Box(Upper)X2, Gear Box(Lower)X2, 10X13X0.2t WasherX6, 1050 Ball bearingX2, 1510 Ball bearingX4, 3X10 Cap screwX10, Front bevel shaftX1, 2X9.8 PinX2, 18T Bevel(S)X1, Center joint cupX2, ϕ1.5 Allen keyX1, ϕ2 Allen keyX1, ϕ2.5 Allen keyX1, ϕWrenchX1, Injection wrenchX1</p>
SB-D	<p>센터샤프트×1, 프론트벌크헤드×1, 전륜로어암×2, 후륜로어암×2, 모터마운트×1, ϕ3 너트×3, 3×8 FH 렌치볼트×9, 3×12 FH 렌치볼트×2, 55mm 힙지핀×4, 모터마운트 베어링홀더×1, 힙지핀 브레이서×1, 3×10 FH 렌치볼트×2, 힙지핀볼×10, 후륜로어암마운트B×1, 후륜로어암마운트A×1, 센터조인트볼×2,</p> <p>Center shaftX1, Front bulk headX1, Front lower armX2, Rear lower armX2, Motor mountX1, ϕ3 NutX3, 3X8 FH Wrench screwX9, 3X12 FH Wrench screwX2, 55mm Hinge pinX4, Motor mount bearing holderX1, Hinge pin braceX1, 3X10 FH Wrench screwX2, Hinge pin ballX10, Rear lower arm mount BX1, Rear lower arm mount AX1, Center joint ballX2</p>
SB-E	<p>ϕ4.3 볼엔드×20, 50mm 로드×4, 44mm 로드×2, 세이버스프링 어저스터×1, ϕ4.3 핀볼×3, 840 오일레스메탈×4, 세이버스프링×1, 3×8 FH 렌치볼트×2, 3×10 RH 렌치볼트×2, ϕ5 E-링×1, 3×6 부시×2, 어퍼데크포스트×2, 스티어링포스트A×1, 스티어링포스트B×1, 스티어링링크×1, 베어링홀더×4, 서보세이버A×1, 서보세이버B×1, 서보세이버C×1, 서보세이버스페이서×1,</p> <p>ϕ4.3 Ball endX20, 50mm RodX4, 44mm RodX2, Saver spring adjustX1, ϕ4.3 Pin ballX3, 840 OillessmetalX4, Saver springX1, 3X8 FH Wrench screwX2, 3X10 RH Wrench screwX2, ϕ5 E-ringX1, 3X6 BushX2, Upper deck postX2, Steering post A X1, Steering post B X1, Steering linkX1, Bearing holderX4, Servo saver AX1, Servo saver BX1, Servo saver CX1, Servo saver spacerX1</p>
SB-F	<p>어퍼데크×1, 전륜댐퍼스테이×1, 후륜댐퍼스테이×1, 배터리 가드×2, 3×8 FH 렌치볼트×4, 3×14 RH 렌치볼트×4, ϕ3 와셔×4, ϕ4.3 핀볼×4, 배터리포스트×2, 3×8 FH 렌치볼트×10, 3×10 FH 렌치볼트×15, 윙스테이(대)×1세트, 윙스테이(소)×1세트, 안테나 포스트×1,</p> <p>Upper deckX1, Front damper stayX1, Rear damper stayX1, Battery protector guardX2, 3X8 FH Wrench screwX4, 3X14 RH Wrench screwX4, ϕ3 WasherX4, Battery postX2, 3X8 FH Wrench screwX10, 3X10 FH Wrench screwX15, Wing stay(Large)X1set, Wing stay(Small)X1set, Antenna postX1</p>
SB-G	<p>허브캐리어(좌)×1, 허브캐리어(우)×1, 전륜허브×2, 후륜허브×2, 1510 볼베어링×6, 디프러브링×4, 4.5×6.5 조인트핀×2, 2×11 조인트핀×2, U 휠허브×2, U 액슬×2, 72mm 샤프트×2, 3×2.5 렌치볼트×2, 4×3×4.5 스텝볼트×4, ϕ4.3 핀볼×6, ϕ2 E-링×9, 26.5mm 힙지핀×2, 33mm 힙지핀×2, 액슬샤프트 스프링×2, ϕ3 나일론너트×2, 72mm 드라이브샤프트×2, 조인트링×2, 액슬×2, 휠허브×2, 볼컵×2</p> <p>Hub carrier(Left)X1, Hub carrier(Right)X1, Front hubX2, Rear hubX2, 1510 Ball bearingX6, Diff. hub ringX4, 4.5X6.5 Joint pinX2, 2X11 Joint pinX2, Universal wheel hubX2, Universal axleX2, 72mm shaftX2, 3X2.5 Wrench screwX2, 4X3X4.5 Step screwX4, ϕ4.3 Pin ballX6, ϕ2 E-ringX9, 26.5mm Hinge pinX2, 33mm Hinge pinX2, Axle shaft springX2, ϕ3 Nylon nutX2, 72mm Drive shaftX2, Joint cup ringX2, AxleX2, Wheel hubX2, Ball cupX2</p>
SB-H	<p>댐퍼스프링(대)×2, 댐퍼스프링(소)×2, 댐퍼파트(옵션)×2세트, 댐퍼캡×4, 댐퍼실린더(대)×2, 댐퍼실린더(소)×2, 댐퍼피스톤1번×4, 댐퍼피스톤2번×4, 댐퍼부시×4, 댐퍼링(보라색)×4, 댐퍼링(파랑)×4, 다이어프램×4, ϕ3 O-링×8, 댐퍼클립 스프링×4, 40mm 댐퍼샤프트×2, ϕ2 E-링×9, ϕ5.8 볼×2, 50mm 댐퍼샤프트×2, 3×12 RH 렌치볼트×2, 3×14 RH 렌치볼트×4, ϕ4.3 핀볼×2, 댐퍼오일통×2, 실리온오일×2</p> <p>Damper spring(L)X2, Damper spring(S)X2, Damper parts(option)X2set, Damper capX4, Damper cylinder(L)X2, Damper piston #1X4, Damper piston #2X4, Damper bushX4, Damper cap(Violet)X4, Damper packingX4, DiaphragmX4, ϕ3 O-ringX8, Damper clip springX4, 40mm Damper shaftX2, ϕ2 E-ringX9, ϕ5.8 BallX2, 50mm Damper shaftX2, 3X12 RH Wrench screwX2, 3X14 RH Wrench screwX4, ϕ4.3 Pin ballX2, Damper oil bottleX2, Silicon oilX2</p>
SB-I	<p>모터 방열핀×1, V2뱀퍼×1, 배터리스트랩×1, 윙×1, 3×10 FH 렌치볼트×2, 윙고정와셔×2, 2.6×10 BH 비스×1, 2.6×10 BH 스크류×1, 양면테이프×1, 서보호스3중×1세트, 서보마운트×2, 3×12 FH 렌치볼트×4, F/H 와셔×4, ϕ4.3 핀볼×1, 바디핀×2, 3×10 FH 렌치볼트×7, 3×3 목각핀×1, 3×10 로드×1, 18T 피니언기어×1</p> <p>Motor heat sinkX1, V2 BumperX1, Battery strapX1, WingX1, 3X10 FH Wrench screwX2, Wing washerX2, 2.6X10 BH Tapping screwX1, 2.6X10 BH ScrewX1, Double side tapeX1, Servo horn setX1, Servo mountX2, 3X12 FH Wrench screwX4, F/H WasherX4, ϕ4.3 Pin ballX1, Body pinX2, 3X10 FH Wrench screwX7, 3X3 Set screwX1, 3X10 RodX1, 18T Pinion gearX1</p>
SB-J	<p>3×18 캡스크류×4, 휠락와셔×4, 전륜디스크휠(28mm)×2, 후륜디스크휠(36mm)×2, 전륜인너폼×2, 후륜인너폼×2, 전륜퓨전타이어×2, 후륜퓨전타이어×2</p> <p>3X18 Cap screwX4, Wheel lock washerX4, Front disk wheel(28mm)X2, Rear disk wheel(36mm)X2, Inner form(F)X2, Inner form(R)X2, Fusion tire(F)X2, Fusion tire(R)X2</p>

■부품이 파손되었거나 분실했을 경우

●부품의 가격 및 판매에 관한 자세한 사항을 본사 서비스센터, 직매점, 총판점 및 가까운 과학교과서에 문의하시고 부품영구 환불정책을 확인하여 구입하시기 바랍니다.

■직매점 및 A/S센터 상업동: 742-9293, 양재동: 575-9997, 문산: 796-1214, 아산하비센터: 6002-5293, 9293
■A/S센터 본사: 908-7000(교원147), 본대분: 745-9293
■총판점 및 A/S센터 서울아카데미: 907-0940, 양천아카데미: 2091-7108, 강남아카데미: 485-6884, 강북아카데미: 782-0980, AB하이브: (031)488-5691, 서면아카데미: (051)818-9773, 대구아카데미: (053)744-9293

■홈페이지 <http://www.academy.co.kr>
■고객상담문의 090-969-7000

ACADEMY
Hobby Model Kit

ACADEMY PLASTIC MODEL CO., LTD.
 273-64, Suyu-dong, Kangbuk-gu, Seoul, Korea
 TEL:82-2-908-7000 FAX:82-2-997-3003

Name : _____
Date : _____
Track : _____

Track conditions

Size : Open Med. Tight

Traction : High Med. Low

Surface : Smooth Bumpy

Front suspension

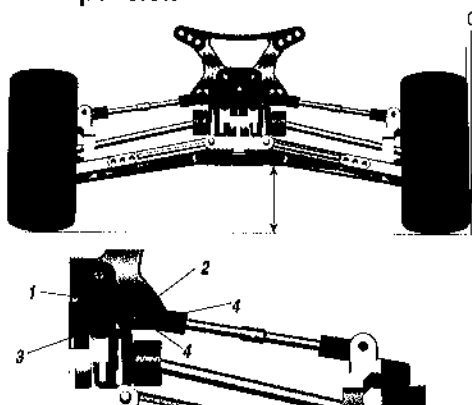

Ride height _____ mm

Camber angle _____ °

Caster angle _____ °

Bulkhead 10° + Hub Carrier 0°, 5°, 7°

Toe angle in/out _____ °

Rebound _____ mm

Upper arm position _____

Front shocks

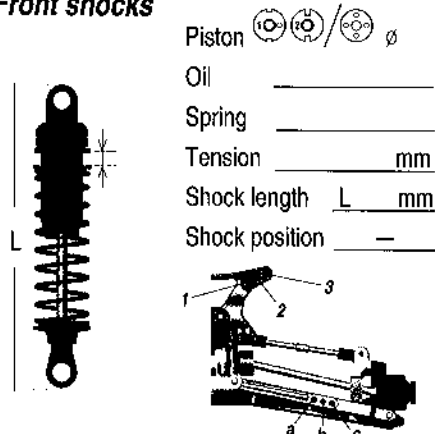

Piston ϕ _____

Oil _____

Spring _____

Tension _____ mm

Shock length L _____ mm

Shock position _____

Rear suspension

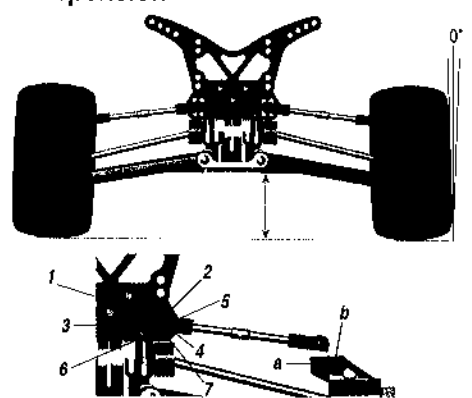

Ride height _____ mm

Camber angle _____ °

Anti-squat 2° _____ °

Rebound _____ mm

Upper arm position _____

Anti-roll bar _____ ϕ

Toe angle 2° _____ °

Rear shocks

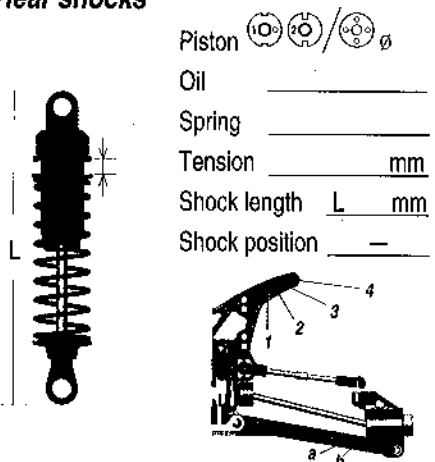

Piston ϕ _____

Oil _____

Spring _____

Tension _____ mm

Shock length L _____ mm

Shock position _____

Steering

Steering rink position _____

Steering servo _____

Steering speed _____ %

Steering curve _____ %



Motor & Battery location



Wing position

Wing _____

Wing angle _____

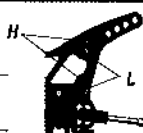

Slipper

Yes No

Soft Medium Hard

Tires & Wheels

Front	Rear
Tire _____	Tire _____
Insert _____	Insert _____
Wheel _____	Wheel _____

Result

Race time / Lap _____

Best lap (1Lap) _____

Front one way

Yes No

Motor _____ T/	Brake _____ %
ESC _____	ABS <input type="checkbox"/> Yes <input type="checkbox"/> No
Battery _____ mA	Matched <input type="checkbox"/> Yes <input type="checkbox"/> No
Drive ratio S T/P T x 2.33 = _____	

Comments

Overall drive ratio

SPUR GEAR		
15T		15
16T		16
17T		17
18T		18
19T		19
20T		20
21T		21
22T		22
23T		23
24T		24
25T		25
26T		26
27T		27
28T		28
29T		29
30T		30
31T		31
32T		32
33T		33