

STR-4 Pro & Sport Part Diagram

ST-P01 Lower Gear Box(F/R)
기어박스 (앞/후)

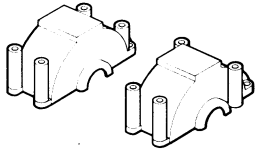

● Lower Gear Box (F/R)
로어기어박스 전/후 2EA

ST-P02 Hub Carrier(5°)
허브 캐리어

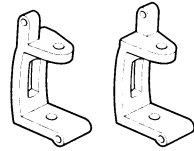

● Hub Carrier(5°) L/R
허브 캐리어(케스터5°)좌우각 1EA

ST-P03 Lower Arm Mount Set
로어 암 마운트 세트

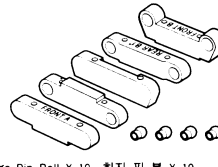

● Hinge Pin Ball X 10 힌지 핀 볼 X 10
● Lower Arm Mount (F·A) X 2 로어 암 마운트 X 2
● Lower Arm Mount (F·B) X 1 로어 암 마운트 X 1
● Lower Arm Mount (R·A) X 1 로어 암 마운트 X 1
● Lower Arm Mount (R·B) X 1 로어 암 마운트 X 1

ST-P04 Bumper
범퍼

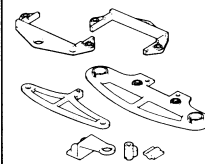

● Center Shaft Spacer X 1
센터 샤프트 스페이서 X 1
● Bumper(Upper)
범퍼(어퍼)
● Bumper(Lower)
범퍼(로어)
● Battery Guard X 2
배터리 가드 X 2
● Phondor Stay X 1
폰다 스테이 X 1
● ANI Post X 1
ANI 포스트 X 1

ST-P05 Body Mount
바디 마운트

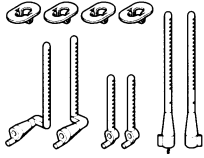

● Body Mount Set X 1 바디 마운트 세트 X 1

ST-P06 Carbon Center Drive Shaft
카본 센터 드라이브 샤프트

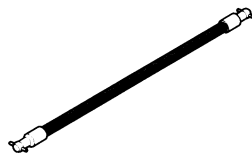

● Carbon Center Drive Shaft X 1
카본 센터 드라이브 샤프트 X 1

ST-P07 AL Center Drive Shaft
알루미늄 센터 드라이브 샤프트

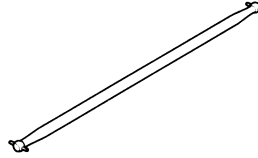

● AL Center Drive Shaft X 1
AL 센터 드라이브 샤프트 X 1

ST-P08 Antivibration Motor Mount (Machine Cut)
진동방지 모터 마운트

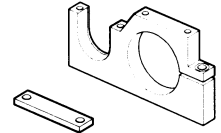

● Bearing Holder X 1 베어링 홀더
● Antivibration Mount X 1 진동 방지 마운트 X 1
● 3X10 Cap Screw X 1 캡 스크류 X 1
● 2X6P/H Screw X 2 스크류 X 2
● 3X6F/h Screw X 3 스크류 X 3

ST-P09 Antivibration Motor Mount
진동방지 모터 마운트

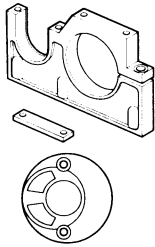

● Antivibration Motor Mount X 1
진동방지 모터 마운트 X 1
● Motor Mount X 1
모터 마운트 X 1
● Bearing Holder X 1
베어링 홀더 X 1
● 2x6 P/H Screw X 2
2x6 P/H 스크류 X 2
● 3x10 Cap Screw X 1
3x10 캡 스크류 X 1
● 3x6 F/H Screw X 5
3x6 F/H 스크류 X 5

ST-P10 AL Post Set
알루미늄 포스트 세트

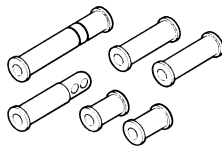

● Battery Strap Post X 1 배터리 스트랩 포스트 X 1
● Upper Deck Post (A) X 2 어퍼 데크 포스트 (A) X 2
● Upper Deck Post (B) X 2 어퍼 데크 포스트 (B) X 2
● Upper Deck Post (C) X 1 어퍼 데크 포스트 (C) X 1

ST-P11 Pivot Ball(A)
피벗 볼(A)



● Pivot Ball(A) X 4 피벗 볼(A) X 4

ST-P12 Pivot Ball(C)
피벗 볼(C)

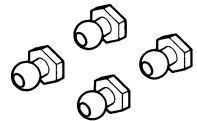

● Pivot Ball(C) X 4 피벗 볼(C) X 4

ST-P13 F/H Washer
washer



● F/H Washer X 10 와셔 X 10

ST-P14 Adjustable Steering Post Set
어드저스터블 스티어링 포스트 세트

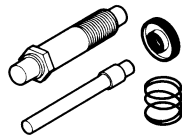

● Adjustable Steering Post X 1
어드저스터블 스티어링 포스트 X 1
● Steering Post X 1 스티어링 포스트 X 1
● Spring Adjuster X 1 스프링 어드저스터 X 1
● Saver Spring X 1 세이버 스프링 X 1

ST-P15 55mm Hinge pin
55mm 힌지 핀

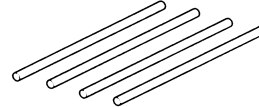

● 55mm Hinge Pin X 4 힌지 핀 X 4

ST-P16 Carbon Chassis
카본 차시

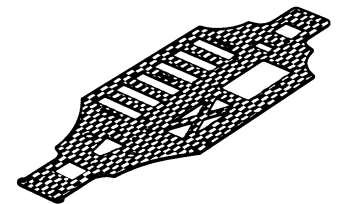

● Carbon Chassis X 1 카본 차시 X 1

ST-P17 Carbon Upper Deck
카본 어퍼 데크

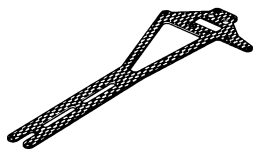

● Carbon Upper Deck X 1 카본 어퍼 데크 X 1

ST-P18 Carbon Battery Strap
카본 배터리 스트랩

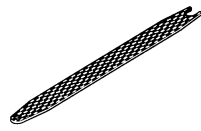

● Carbon Battery Strap X 1 카본 배터리 스트랩 X 1

ST-P19 FRP Chassis
FRP 차시

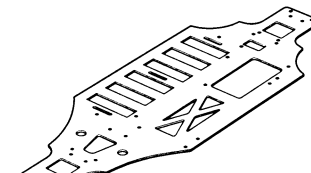

● FRP Chassis X 1 차시 X 1

ST-P20 FRP Upper Deck Set
FRP 어퍼 데크 세트

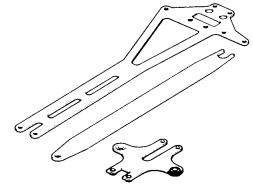

● FRP Front Upper Plate X 1 프론트 어퍼 플레이트 X 1
● FRP Upper Deck X 1 어퍼 데크 X 1
● FRP Battery Strap X 1 배터리 스트랩 X 1
● Front Upper Plate Spacer X 2 프론트 어퍼 스페이서 X 2

- 직매점 겸 A/S센터
- A/S센터
- 총판점 겸 A/S 센터

삼선교:742-9293, 방배동:552-9293, 양재동:575-9997, 용산:796-1214, 아셈하비센터: 6002-6293

본사:908-7000 (교환 147), 동대문:745-9293, 천호동:473-9293

노원아카데미:907-0940, 양천아카데미:691-7108, 강남아카데미:485-6884, 경기아카데미:(031)458-5591,

강북아카데미:762-0980, 부산아카데미:(051)293-7449, 대구아카데미:(053)744-9293

♣ 고객상담문의

080-969-7000

■ 홈페이지

<http://www.academy.co.kr>

<http://www.academyhobby.com>

ACADEMY
HOBBY MODEL KITS

ACADEMY PLASTIC MODEL CO.,LTD.

273-64, Suyu-dong, Kangbuk-gu, Seoul, Korea

TEL:82-2-908-7000 FAX:82-2-997-3003

SPARE & TUNING PARTS DIAGRAM



SPARE PART

<p>ST-01 Chassis ₩17,000 샴시</p> <p>● Chassis 샴시 ×1</p>	<p>ST-02 Gear box (F-R) ₩5,000 기어 박스</p> <p>● F. Gear box 전륜 기어 박스 ×1 ● R. Gear box 후륜 기어 박스 ×1</p>	<p>ST-03 F-R Hub ₩3,000 전·후 허브</p> <p>● Knuckle Arm(Front Hub) 전륜 허브 ×1 ● Rear Hub 후륜 허브 ×1 ● Hub Spacer 허브 스페이서 ×2</p>	<p>ST-04 Hub Carrier ₩3,000 허브 캐리어</p> <p>● Hub Carrier 허브 캐리어 ×2</p>	
<p>ST-05 Battery Strap ₩4,000 배터리 스트랩</p> <p>● Front upper plate 전륜 여퍼 플레이트 ×1 ● Rear bracer 후륜 브레이서 ×1 ● Battery Strap 배터리 스트랩 ×1</p>	<p>ST-06 35T Bevel Gear ₩4,000 35T 베벨 기어</p> <p>● 35T Bevel Gear 35T 베벨 기어 ×2 ● Diff Case 디프 케이스 ×2 ● #2.6×14 F/H Tapping Screw #2.6×14 침시 비스 ×8</p>	<p>ST-07 Servo Saver ₩4,000 서어보 세이버</p> <p>● Steering Servo Mount ×2 스티어링 서보 마운트 ● Speed Control Mount ×1 스피드 컨트롤 마운트 ● 840Bush 840 부쉬 ×4 ● Speed control Adapter ×1 스피드 컨트롤 어댑터 ● Steering Arm 스티어링 암 ×2 ● Servo Saver 서보 세이버 ×1조 ● Battery Strap Post ×1 배터리 스트랩 포스트 ● Servo Horn 서어보 호른 ×3</p>	<p>ST-08 Bumper ₩4,000 범퍼</p> <p>● Front Bumper 전륜 범퍼 ×1 ● Rear Bumper 후륜 범퍼 ×1</p>	
<p>ST-09 Damper Stay ₩5,000 댐퍼 스테이</p> <p>● Front Damper Stay 전륜 댐퍼 스테이 ×1 ● Rear Damper Stay 후륜 댐퍼 스테이 ×1</p>	<p>ST-10 Motor Mount ₩2,000 모터 마운트</p> <p>● Motor Mount 모터 마운트 ×1</p>	<p>ST-11 Wheel Hub ₩2,000 휠 허브</p> <p>● Wheel Hub 휠 허브 ×4</p>	<p>ST-12 Center Drive Shaft ₩2,000 센터 드라이브 샤프트</p> <p>● Center Drive Shaft 센터 드라이브 샤프트 ×1 ● Center Shaft Spacer 센터 샤프트 스페이서 ×1</p>	<p>ST-13 Spur Gear ₩2,500 스퍼 기어</p> <p>● #3×6 B/H Screw #3×6 볼트 ×4 ● Spur Gear 스퍼 기어 ×1 ● Spur Gear Adapter 스퍼 기어 어댑터 ×1</p>
<p>ST-14 Body Mount ₩2,000 바디 마운트</p> <p>● Body Mount 바디 마운트 ×1Set ● Body Mount Swivel 바디 마운트 완창 ×4</p>	<p>ST-15 Upper Rod ₩2,000 어퍼 로드</p> <p>● Front Upper Rod 전륜 어퍼 로드 ×2 ● Rear Upper Rod 후륜 어퍼 로드 ×2 ● Steering Rinke Rod 스티어링 링크 로드 ×2</p>	<p>ST-16 Lower Arm ₩3,000 로워 암</p> <p>● Front Lower Arm 전륜 로워 암 ×1 ● Rear Lower Mount 후륜 로워 마운트 ×1</p>	<p>ST-17 Front Center Bevel/Shaft ₩2,000 전륜 센터 베벨/샤프트</p> <p>● Front Center Bevel/Shaft 전륜 센터 베벨/샤프트 ×1</p>	<p>ST-18 Rear Center Bevel/Shaft ₩3,000 후륜 센터 베벨/샤프트</p> <p>● #2×10 Drive Pin #2×10 드라이브 핀 ×1 ● Rear Center Bevel/Shaft 후륜 센터 베벨/샤프트 ×1</p>
<p>ST-19 Center Joint Cup ₩3,000 센터 조인트 컵</p> <p>● #4×4 Set Screw #4×4 세트 스크류 ×2 ● Center Joint Cup 센터 조인트 컵 ×2</p>	<p>ST-20 50mm Hinge Pin ₩2,000 한지 핀</p> <p>● 50mm Hinge Pin 한지 핀 ×2</p>	<p>ST-21 Axle Shaft ₩5,000 액슬 샤프트</p> <p>● Axle Shaft 액슬 샤프트 ×2 ● #2×10 Drive Pin 드라이브 핀 ×2</p>	<p>ST-22 Joint Cup Spring ₩1,000 조인트 컵 스프링</p> <p>● Joint Cup Spring 조인트 컵 스프링 ×5</p>	<p>ST-23 Drive Shaft ₩4,000 드라이브 샤프트</p> <p>● Drive Shaft 드라이브 샤프트 ×2</p>

ST-24 Damper Spring
₩1,000
 댐퍼 스프링

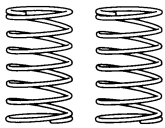

● Damper Spring 댐퍼 스프링 × 2

ST-25 Steering Post Set
₩4,000
 스티어링 포스트 세트

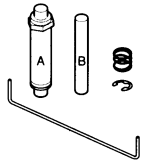

● Steering Post A 스티어링 포스트 × 1
 ● Steering Rod B 스티어링 로드 × 1
 ● Steering Rod 스티어링 로드 × 1
 ● Saver Spring 세이버 스프링 × 1
 ● E-ring 이링 × 1

ST-26 Diff Case Bush
₩3,000
 디프 케이스 부쉬

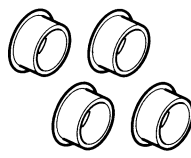

● Diff Case Bush 디프 케이스 부쉬 × 4

ST-27 Damper Shaft
₩3,000
 댐퍼 샤프트



● Damper Shaft 댐퍼 샤프트 × 4

ST-28 25T Pinion Gear
₩3,500
 25T 피니온 기어(48P)



● 25T Pinion Gear 25T 피니온 기어 × 1
 ● #3×3 Set Screw #3×3셋트 스크류 × 2

ST-29 Battery Spacer
₩1,000
 배터리 스페이서

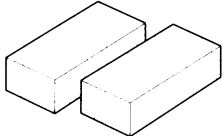

● Battery Spacer 배터리 스페이서 × 2

ST-30 Battery Pad
₩1,000
 배터리 패드

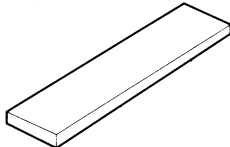

● Battery Pad 배터리 패드 × 1

ST-31 Tire
₩5,000
 타이어

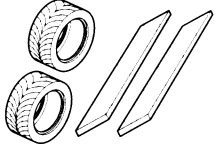

● Tire 타이어 × 2
 ● Inner Sponge 인너 스폰지 × 2

ST-34 Rally Block Tire
₩5,500
 랠리 블럭 타이어

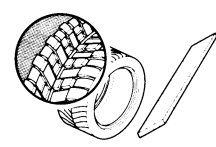

● Rally Block Tire 랠리 블럭 타이어 × 2
 ● Inner Sponge 인너 스폰지 × 2

ST-35 Lower Arm(for Rally)
₩3,500
 로워 암(랠리용)

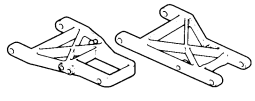

● Front Lower Arm 전면 로워 암 × 1
 ● Rear Lower Arm 후면 로워 암 × 1

ST-36 Inner Body(for Rally)
₩5,000
 인너 바디(랠리용)



● Inner Body 인너 바디 × 1
 ● Doll 인형 × 2
 ● #3×8 P/H Tapping Screw #3×8 P/H 태핑 스크류 × 4
 ● #3×8 Washer #3×8 와셔 × 2
 ● Magic Tape Ⓞ, Ⓢ(Vetco Tape) 매직 테이프 Ⓞ, Ⓢ × 1

ST-37 Drive Shaft(for Rally)
₩4,000
 드라이브 샤프트(랠리용)

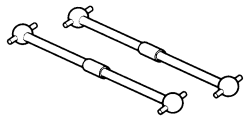

● Drive Shaft 드라이브 샤프트 × 2

ST-32	STR-4 BETA Body STR-4 베타 바디	₩28,000
ST-33	STR-4 ALFA Body STR-4 알파 바디	₩28,000
ST-38	STR-4 Rally F Body STR-4 랠리 에프 바디	₩28,000
GRS-6	Arm Mount 암 마운트	₩2,500
GRS-24	Hinge Pin(26mm) 힌지 핀	₩2,000
GRS-25	Hinge Pin(33mm) 힌지 핀	₩1,000
K0501/1	Damper case 댐퍼 케이스	₩3,000
K0501/2	Damper Part's - B 댐퍼 파트	₩5,000
K0501/3	Damper Cap - B 댐퍼 캡	₩6,500
K0501/4	Oil Seal Cap - B 오일 씰 캡	₩3,500
D0508	Diaphragm(Rubber cap) 고무 캡	₩4,000

TUNING PART

ST-T01 Ball Diff. Set
₩24,000
 볼 디프 세트

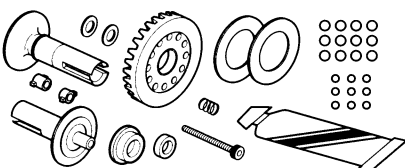

● Ball diff. bevel gear 볼 디프 베벨 기어 × 1
 ● Ball diff. joint cup(A,B) 볼디프 조인트 컵 × 1
 ● Ball diff. washer 볼디프 와셔 × 2
 ● Thrust washer 트러스트 와셔 × 2
 ● Diff. spring 디프 스프링 × 1
 ● #3×28 Cap screw 캡 스크류 × 1
 ● #3 Diff. ball 디프 볼 × 12
 ● #1.5 Thrust ball 트러스트 볼 × 9
 ● Silicon grease 실리콘 그리스 × 1
 ● 850 Oilless metal bearing 오일리스 메탈 베어링 × 1
 ● Injection nut 사출 너트 × 1
 ● F1050 Ball bearing 볼렌지 볼 베어링 × 1

ST-T02 Slipper Clutch Set
₩18,000
 슬리퍼 클러치 세트

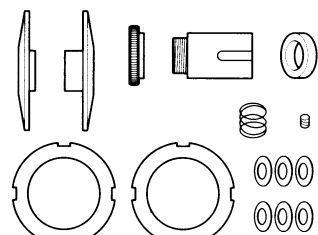

● Slipper disk A,B 슬리퍼 디스크 A,B × 1
 ● Slipper joint cup 슬리퍼 조인트 컵 × 1
 ● Slipper joint nut 슬리퍼 조인트 너트 × 1
 ● P-1 clutch disk P-1 클러치 디스크 × 2
 ● Pressure spring 압력 스프링 와셔 × 6
 ● Joint cup spring 조인트 컵 스프링 × 1
 ● #4×4 Set screw #4×4 셋트 스크류 × 1
 ● 1510 Oilless metal 1510오일리스 메탈 × 1

ST-T03 Al Motor Mount Set
₩25,000
 알루미늄 모터 마운트 세트

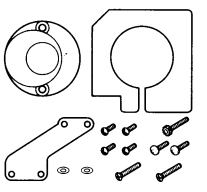

● Motor mount set × 3
 알루미늄 세트
 ● #3×8 F/H Screw × 2
 ● #3×8 F/H 볼트
 ● #3×8 B/H Screw × 2
 ● #3×8 B/H 볼트
 ● #3×6 B/H Screw × 4
 ● #3×6 B/H 볼트
 ● #3×8 Washer × 2
 ● #3×8 와셔
 ● #3×12 Cap screw × 1
 ● #3×12 캡 스크류

ST-T04 Al Spur Gear Adapter
₩5,000
 알루미늄 스파기어 어댑터



● Spur gear adapter 스파 기어 어댑터 × 1
 ● #3×6 B/H Screw 볼트 × 4

ST-T05 Al Wheel Hub
₩6,000
 알루미늄 휠 허브

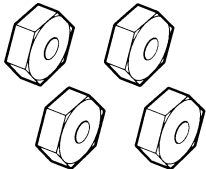

● Al wheel hub 알루미늄 휠 허브 × 4

ST-T06 Universal Shaft
₩17,000
 유니버설 샤프트

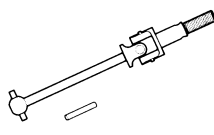

● Universal shaft 유니버설 샤프트 × 2
 ● #2×10 Drive pin #2×10 드라이브 핀 × 2

ST-T07 Manufacturing 11T Front Center Bevel Shaft
₩7,000
 제조용 11T 전면 센터 베벨 샤프트

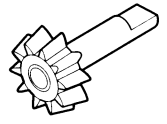

● 11T Front center Bevel shaft 11T 전면 센터 베벨 샤프트 × 1

ST-T08 Manufacturing 11T Rear Center Bevel Shaft
₩8,000
 제조용 11T 후면 센터 베벨 샤프트



● 11T Rear center Bevel shaft 11T 후면 센터 베벨 샤프트 × 1
 ● #2×10 Drive pin #2×10 드라이브 핀 × 1

ST-T09 11T Bevel One Way Shaft
₩3,500
 11T 베벨 원웨이 샤프트



● 11T Bevel one way shaft 11T 베벨 원웨이 샤프트 × 1

ST-T10 Center One Way Joint Cup
₩14,000
 센터 원웨이 조인트 컵



● Center one way joint cup 센터 원웨이 조인트 컵 × 1

ST-T11 Al Center Drive Shaft
₩7,000
 알루미늄 센터 드라이브 샤프트

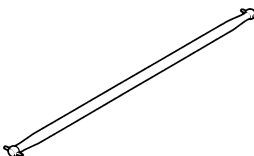

● Al center drive shaft 알루미늄 센터 드라이브 샤프트 × 1

ST-T12 Carbon Center Drive Shaft
₩15,000
 카본 센터 드라이브 샤프트

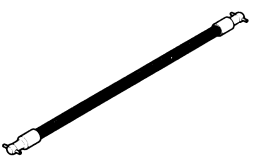

● Carbon center drive shaft 카본 센터 드라이브 샤프트 × 1

ST-T13 Ball Diff Hub
볼 디프 허브
₩13,000



●Ball diff hub A, B 볼 디프 허브 A, B ×1

ST-T14 Ball Diff Bevel Gear
볼 디프 베벨 기어
₩3,000

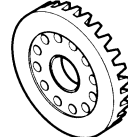

●Ball diff bevel gear 볼 디프 베벨 기어 ×1

ST-T15 Ball Diff Screw
디프용 캡 스크류
₩2,000



●사출너트(CA165-6) ×1
●#3×28 Cap screw #3×28 캡 스크류 ×1
●Silver ball diff spring 실버볼 디프 스프링 ×1

ST-T16 Sliper Disk
슬리퍼 디스크
₩12,000

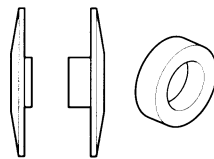

●Disk A 디스크 A ×1
●Disk B 디스크 B ×1
●1510 Oilless metal 1510오일리스 메탈 ×1

ST-T17 Sliper Joint
슬리퍼 조인트
₩3,000

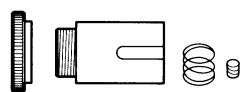

●Sliper joint nut 슬리퍼 조인트 너트 ×1
●Sliper joint cup 슬리퍼 조인트 컵 ×1
●#4×4 Set screw #4×4 세트 스크류 ×1
●Axle shaft spring 액슬 샤프트 스프링 ×1

ST-T18 Pressure Spring
프레셔 스프링
₩1,000

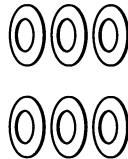

●Pressure spring 프레셔 스프링 ×6

ST-T19 PI Clutch Disk
PI 클러치 디스크
₩5,000

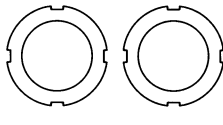

●PI clutch disk PI 클러치 디스크 ×2

ST-T20 AI Motor Mount
알루미늄 모터마운트
₩6,000

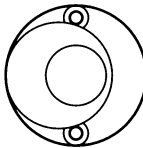

●Motor mount^㉔ 모터 마운트^㉔ ×1

ST-T21 AI Motor Mount
알루미늄 모터마운트
₩15,000

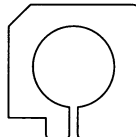

●Motor mount^㉔ 모터 마운트^㉔ ×1

ST-T22 Motor Mount Brace
모터 마운트 브레이스
₩7,000

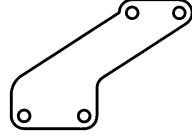

●Motor mount brace 모터 마운트 브레이스 ×1

ST-T23 Carbon Front Upper Plate
카본 프론트 아퍼 플레이트
₩17,000

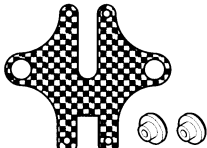

●Carbon front upper plate 카본 프론트 아퍼 플레이트 ×1
●Upper plate spacer 아퍼 플레이트 스페이스 ×2

ST-T24 Carbon Rear Brace
카본 리어 브레이스
₩10,000

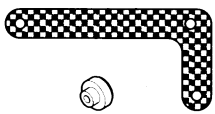

●Carbon rear brace 리어 브레이스 ×1
●Rear brace spacer 리어 브레이스 스페이스 ×1

ST-T25 Carbon Battery Strap
카본 배터리 스트랩
₩13,000



●Carbon Battery strap 배터리 스트랩 ×1

ST-T26 Front Stabilizer
전륜 스테빌라이저
₩5,000

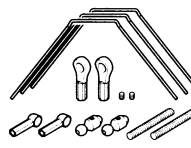

●Front stabilizer 전륜 스테빌라이저 #16 #17 #18×1
●Stabilizer ball 스테빌라이저 볼 ×2
●#3×3 Set screw #3×3 세트 스크류 ×2 ●#43 Ball end 볼 엔드 ×2
●#5.8 Ball end 볼 엔드 ×2 ●#3×15 Rod 로드 ×2

ST-T27 Rear Stabilizer
후륜 스테빌라이저
₩5,000

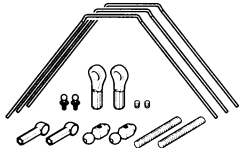

●Rear stabilizer 후륜 스테빌라이저 #16 #17 #18×1
●Stabilizer ball 스테빌라이저 볼 ×2 ●#43 Ball end 볼 엔드 ×2
●#3×3 Set screw #3×3 세트 스크류 ×2 ●#3×15 Rod 로드 ×2
●#5.8 Ball end 볼 엔드 ×2 ●#43 Pin 볼 ×2

ST-T28 62T, 65T Spur Gear
62T, 65T 스퍼 기어(48P)
₩4,000

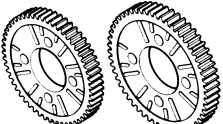

●62T, 65T Spur gear 62T, 65T 스퍼 기어 ×1

ST-T29 67T, 70T Spur Gear
67T, 70T 스퍼 기어(48P)
₩4,000

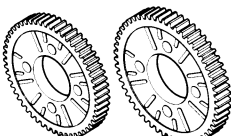

●67T, 70T Spur gear 67T, 70T 스퍼 기어 ×1

ST-T30 27T Pinion Gear
27T 피니온 기어(48P)
₩4,000



●27T Pinion gear 27T 피니온 기어 ×1
●#3×3 Set screw #3×3 세트 스크류 ×1

ST-T31 29T Pinion Gear
29T 피니온 기어(48P)
₩4,000



●29T Pinion gear 29T 피니온 기어 ×1
●#3×3 Set screw #3×3 세트 스크류 ×1

ST-T32 31T Pinion Gear
31T 피니온 기어(48P)
₩4,000

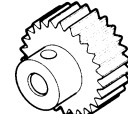

●31T Pinion gear 31T 피니온 기어 ×1
●#3×3 Set screw #3×3 세트 스크류 ×1

ST-T33 33T Pinion Gear
33T 피니온 기어(48P)
₩4,000



●33T Pinion gear 33T 피니온 기어 ×1
●#3×3 Set screw #3×3 세트 스크류 ×1

ST-T34 35T Pinion Gear
35T 피니온 기어(48P)
₩4,000



●35T Pinion gear 35T 피니온 기어 ×1
●#3×3 Set screw #3×3 세트 스크류 ×1

ST-T35 Foam Bumper
스폰지 범퍼
₩4,000

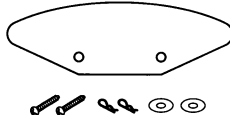

●Foam bumper 스폰지 범퍼 ×1
●Hook pin 후크핀 ×2
●#5×16 Nylon washer 나일론 와셔 ×2
●#3×15 P/4 Tapping screw #3×15 P/4 태핑 스크류 ×2

ST-T36 Special Damper Set
스페셜 댐퍼 세트
₩20,000

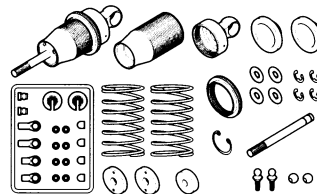

●Damper body 댐퍼바디 ×2
●Damper cap 댐퍼캡 ×2
●Spring adjuster 스프링 어저스터 ×2
●#2 Teflon Damper piston #2 테플론 댐퍼 피스톤 ×2
●Damper bush 댐퍼 부쉬 ×2
●Damper shaft 댐퍼 샤프트 ×2
●#8 Snap ring 링 ×2
●#3 Silicon O-ring 링 ×4
●#2 E-ring 링 ×4
●Diaphragm 다이어그램 ×2
●Damper part 댐퍼파트 ×1
●#4.3 Pin ball #4.3 핀볼 ×2
●#5.8 ball #5.8 볼 ×2
●Damper spring 댐퍼스프링 ×2

ST-T37 Two Step Damper Spring Set(S)
투스텝 댐퍼 스프링 세트(S)
₩6,000

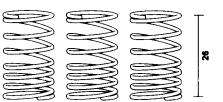

●#1.2 Damper spring(Orange) #1.2 댐퍼 스프링(주황) ×2
●#1.3 Damper spring(Yellow) #1.3 댐퍼 스프링(황광노랑) ×2
●#1.4 Damper spring(Green) #1.4 댐퍼 스프링(형광연두) ×2

ST-T38 Two Step Damper Spring Set(L)
투스텝 댐퍼 스프링 세트(L)
₩6,000

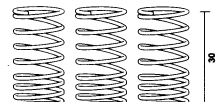

●#1.2 Damper spring(Orange) #1.2 댐퍼 스프링(주황) ×2
●#1.3 Damper spring(Yellow) #1.3 댐퍼 스프링(황광노랑) ×2
●#1.4 Damper spring(Green) #1.4 댐퍼 스프링(형광연두) ×2

ST-T39 Front One Way Set
가격미정
전륜 원웨이 세트



ST-T40 Adjustable Steering Post Set
어드저스태빌 스티어링 포스트 세트
₩5,000







●Adjustable steering post 어드저스태빌 스티어링 포스트 ×1
●Spring adjuster 스프링 어저스터 ×1
●Steering post 스티어링 포스트 ×1
●Saver spring 세이버 스프링 ×1
●#3 E-ring 링 ×1

ST-T41 #1 Teflon Damper Piston
#1 테플론 댐퍼 피스톤
₩2,500

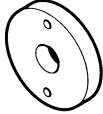

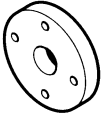
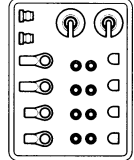
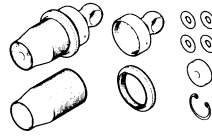
●#1 Teflon Damper piston #1 테플론 댐퍼 피스톤 ×4

ST-T42 #2 Teflon Damper Piston ₩2,500  ● #2 Teflon Damper piston #2 테플론 댐퍼 피스톤 ×4	ST-T43 #3 Teflon Damper Piston ₩2,500  ● #3 Teflon Damper piston #3 테플론 댐퍼 피스톤 ×4	ST-T44 #4 Teflon Damper Piston ₩2,500  ● #4 Teflon Damper piston #4 테플론 댐퍼 피스톤 ×4	ST-T45 Damper Part ₩2,000  ● Damper part 댐퍼 파트 ×1	ST-T46 Special Damper Body Set ₩16,000  ● Damper body 댐퍼 바디 ×2 ● Damper cap 댐퍼 캡 ×2 ● Spring adjuster 스프링 어저스터 ×2 ● Damper bush 댐퍼 부쉬 ×2 ● #8 Snap ring 스냅 링 ×2 ● #3 Silicon O-ring 링 ×4	ST-T47 One Way Body 가격미정 
--	--	--	---	--	---

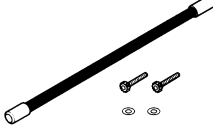
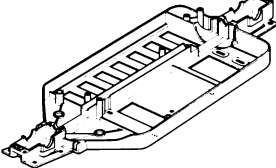
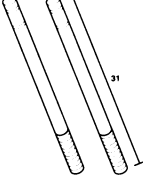
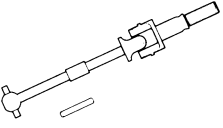
ST-T48 One Way Shaft(L-R) 가격미정 	ST-T49 Carbon Torque Bar ₩20,000  ● Carbon torque bar 카본 토크바 ×1 ● #3 × 10 Cap screw 캡 스크류 ×2 ● #3 × 8 Washer #3 × 8 와셔 ×2	ST-T50 Light Weight Chassis(for Race) ₩23,000  ● Light weight chassis(for race) 경량 새시(경기용) ×1	ST-T51 Damper Shaft(for Rally) ₩2,000  ● Damper Shaft 댐퍼 샤프트 ×2	ST-T52 Universal Shaft(for Rally) ₩17,000  ● Universal shaft 유니버설 샤프트 ×2 ● #2 × 10 Drive pin #2 × 10 드라이브 핀 ×2
---	--	--	--	--

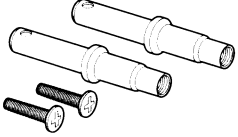
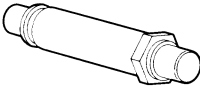
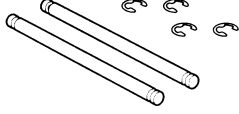
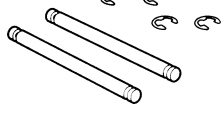
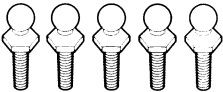
GRT-T03 Al. Battery Strap Post ₩3,000  ● Al. Battery strap post 알루미늄 배터리 스트랩 포스트 ×2 ● #3 × 12 F/H screw #3 × 12 ×2	GRT-T06 Al. Steering Post ₩3,000  ● Al. Steering post 알루미늄 스티어링 포스트 ×1	GRT-T09 Al. Hinge Pin(33mm) ₩2,500  ● Al. Hinge pin(33mm) 알루미늄 힌지 핀 (33mm) ×2 ● #2 E-ring 링 ×4	GRT-T10 Al. Hinge Pin(26mm) ₩2,500  ● Al. Hinge pin(26mm) 알루미늄 힌지 핀 (26mm) ×2 ● #2 E-ring 링 ×4	GRT-T12 Al. #4.3 Pin Ball(Purple) ₩4,000  ● Al. #4.3 Pin ball(Purple) 알루미늄 #4.3 핀 볼(퍼플) ×5
--	--	---	--	--

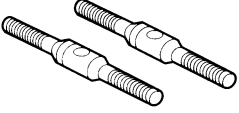
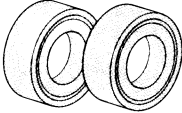
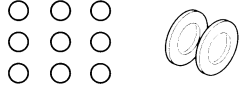
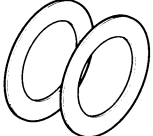
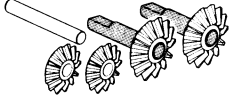
GRT-T17 Al. Turnbuckle Rod(26mm) ₩3,500  ● Al. Turnbuckle rod(26mm) 알루미늄 턴버클 로드(26mm) ×2	WT-01 850 Ball Bearing ₩6,000  ● 850 Ball bearing 850 볼 베어링 ×2	WT-23 Thrust Bearing Set ₩2,000  ● Thrust ball 트러스트 볼 ×9 ● Thrust washer 트러스트 와셔 ×2	WT-25 Ball Diff. Disk Washer ₩1,000  ● Ball diff. disk washer 디프용 디스크 와셔 ×2	AS-045 F/R Diff. Gear ₩6,000  ● 13T Bevel gear 베벨 기어 ×2 ● 10T Bevel gear 베벨 기어 ×2 ● #3 × 20 Shaft 샤프트 ×1
--	---	---	--	---

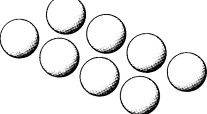
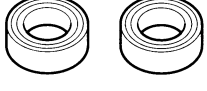
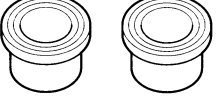
EXT-16 #3 Diff. Ball ₩3,000  ● #3 Diff. ball 디프 볼 ×8	TRT-3 840 Ball Bearing ₩6,000  ● 840 Ball bearing 볼 베어링 ×2	TRT-4 840 Flange Ball Bearing ₩12,000  ● 840 Flange ball bearing 플랜지 볼 베어링 ×2	<table border="1"> <tr> <td>WT-02</td> <td>1050 Ball Bearing 1050 볼 베어링 -</td> <td>₩7,000</td> </tr> <tr> <td>K0603</td> <td>1510 Ball Bearing 1510 볼 베어링</td> <td>₩7,000</td> </tr> <tr> <td>K1114</td> <td>Corolla Wheel(White) 코롤라 휠 (백색)</td> <td>₩2,000</td> </tr> <tr> <td>K1114S</td> <td>Corolla Wheel(Silver) 코롤라 휠 (은색)</td> <td>₩2,500</td> </tr> <tr> <td>K1114B</td> <td>Corolla Wheel(Black) 코롤라 휠 (검정)</td> <td>₩2,000</td> </tr> <tr> <td>K1116</td> <td>Honda Wheel 혼다 휠</td> <td>₩2,000</td> </tr> <tr> <td>K1118</td> <td>Peugeot Wheel 푸조 휠</td> <td>₩2,000</td> </tr> <tr> <td>K1121</td> <td>Radial tire 레디알 타이어</td> <td>₩8,000</td> </tr> <tr> <td>K1120</td> <td>Slick tire 슬릭 타이어</td> <td>₩8,000</td> </tr> </table>	WT-02	1050 Ball Bearing 1050 볼 베어링 -	₩7,000	K0603	1510 Ball Bearing 1510 볼 베어링	₩7,000	K1114	Corolla Wheel(White) 코롤라 휠 (백색)	₩2,000	K1114S	Corolla Wheel(Silver) 코롤라 휠 (은색)	₩2,500	K1114B	Corolla Wheel(Black) 코롤라 휠 (검정)	₩2,000	K1116	Honda Wheel 혼다 휠	₩2,000	K1118	Peugeot Wheel 푸조 휠	₩2,000	K1121	Radial tire 레디알 타이어	₩8,000	K1120	Slick tire 슬릭 타이어	₩8,000
WT-02	1050 Ball Bearing 1050 볼 베어링 -	₩7,000																												
K0603	1510 Ball Bearing 1510 볼 베어링	₩7,000																												
K1114	Corolla Wheel(White) 코롤라 휠 (백색)	₩2,000																												
K1114S	Corolla Wheel(Silver) 코롤라 휠 (은색)	₩2,500																												
K1114B	Corolla Wheel(Black) 코롤라 휠 (검정)	₩2,000																												
K1116	Honda Wheel 혼다 휠	₩2,000																												
K1118	Peugeot Wheel 푸조 휠	₩2,000																												
K1121	Radial tire 레디알 타이어	₩8,000																												
K1120	Slick tire 슬릭 타이어	₩8,000																												

<ul style="list-style-type: none"> 직매점 겸 A/S센터 A/S센터 총판점 겸 A/S 센터 	<ul style="list-style-type: none"> 홈페이지 고객상담문의 	<p>삼선교: 742-9293, 대치동: 552-9293, 양재동: 575-9997, 용산: 796-1214 본사: 908-7000 (교환 147), 동대문: 745-9293, 천호동: 473-9293 노원아카데미: 907-0940, 양천아카데미: 691-7108, 강남아카데미: 522-1577, 경기아카데미: (0343)458-5591, 강북아카데미: 762-0980, 부산아카데미: (051)293-7449, 대구아카데미: (053)744-9293</p> <p>http://www.academy.co.kr http://www.academyhobby.com</p> <p>080-969-7000</p>	<p>ACADEMY HOBBY MODEL KITS</p> <p>ACADEMY PLASTIC MODEL CO., LTD. 273-64, Suyu-dong, Kangbuk-gu, Seoul, Korea TEL: 82-2-908-7000 FAX: 82-2-997-3003</p>
--	--	--	---

New Product Tuning Parts Diagram

ST-T39 Front One Way Set
 전륜 원 웨이 세트 (2.75:1)



- One Way Hub X 1 원 웨이 허브 X 1
- One Way Joint X 2 원 웨이 조인트 X 2
- 44T Bevel Gear X 1 44T 베벨 기어 X 1
- 16T Bevel Gear X 1 16T 베벨 기어 X 1
- #2x4 Screw X 6 볼트 X 6

ST-T47 Front One Way Hub
 원 웨이 허브 (2.75:1)

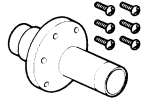

- One Way Hub X 1 원 웨이 허브 X 1
- #2x4 Screw X 6 볼트 X 6

ST-T48 Front One Way Joint
 원 웨이 조인트 (L/R)

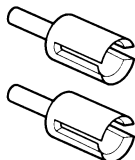

- One Way Joint X 2 원 웨이 조인트 X 2

ST-T53 Damper Shaft (for Touring)
 댐퍼 샤프트

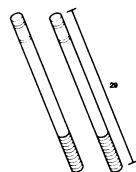

- 29mm Damper Shaft X 2 댐퍼 샤프트 X 2

ST-T54 Ball Diff Set (2.75:1)
 볼 디프 세트

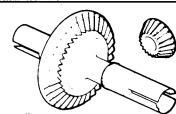

- Ball Diff Hub L/R X 1 볼 디프 허브 X 1
- Ball Diff Washer X 2 볼 디프 와셔 X 2
- #2 X 6 Thrust Washer X 2 트러스트 와셔 X 2
- #2.5 Diff Ball X 12 디프 볼 X 12
- #2 Thrust Ball X 6 트러스트 볼 X 6
- Diff Spring X 1 디프 스프링 X 1
- 44T Bevel Gear X 1 베벨 기어 X 1
- 16T Bevel Gear X 1 베벨 기어 X 1
- 850 Bush X 2 부시 X 2
- Ball Diff Nut X 1 볼 디프 너트 X 1
- Ball Diff Screw X 1 볼 디프 스크류 X 1

ST-T55 Center One Way Shaft (2.75:1)
 센터 원 웨이 샤프트

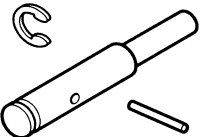

- Center One Way Shaft X 1 센터 원 웨이 샤프트 X 1
- C Stop Ring X 1 C 스톱 링 X 1
- #1.5 X 7.5 Pin X 1 핀 X 1

ST-T56 F/R Bevel Gear Shaft (2.75:1)
 전/후 베벨 기어 샤프트



- Front Bevel Gear Shaft X 1 프론트 베벨 기어 샤프트 X 1
- Rear Bevel Gear Shaft X 1 리어 베벨 기어 샤프트 X 1
- C Stop Ring X 2 C 스톱 링 X 2
- #1.5X7.5 Pin X 2 핀 X 2
- #2X10 Drive Pin X 1 드라이브 핀 X 1

ST-T57 Bevel Gear (2.75:1)
 베벨 기어

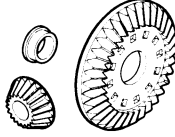

- 44T Bevel Gear X 1 베벨 기어 X 1
- 16T Bevel Gear X 1 베벨 기어 X 1
- Bush X 1 부시 X 1

ST-T58 Ball Diff Hub (2.75:1)
 볼 디프 허브

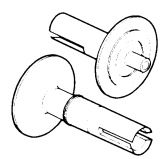

- Ball Diff Hub (L - R) X 1 볼 디프 허브 X 1

ST-T59 Standard Spur Gear Adapter
 표준 스퍼 기어 어댑터



- Standard Spur Gear Adapter X 1 스탠다드 스퍼 기어 어댑터 X 1
- #3 X 6 Screw X 4 볼트 X 4

ST-T60 0406 One Way Bearing
 0406 원 웨이 베어링



- 0406 One Way Bearing X 2 원 웨이 베어링 X 2

ST-T61 Antivibration Motor Mount Set
 진동방지 모터 마운트 세트



- Bearing Holder X 1 베어링 홀더 X 1
- Motor Mount Brace X 1 모터 마운트 브레이스 X 1
- Motor Mount X 1 모터 마운트 X 1
- #3X8 Cap Screw X 1 캡 스크류 X 1
- #2X6 P/H Screw X 1 볼트 X 1
- #3X6 B/H Screw X 6 볼트 X 6
- #3X8 Washer X 2 와셔 X 2
- Antivibration Motor Mount X 1 진동 방지 모터 마운트 X 1

ST-T62 Antivibration Motor Mount
 진동방지 모터 마운트

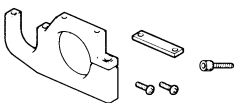

- Antivibration Motor Mount X 1 진동 방지 모터 마운트 X 1
- Bearing Holder X 1 베어링 홀더 X 1
- #2X6 P/H Screw X 2 스크류 X 2
- #3X8 Cap Screw X 1 캡 스크류 X 1

ST-T63 Ball Diff Screw Set
 볼 디프 스크류 세트



- Ball Diff Screw X 1 볼 디프 스크류 X 1
- Ball Diff Spring X 1 볼 디프 스프링 X 1
- #2X6 Thrust Washer X 2 트러스트 와셔 X 2
- #2 Thrust Ball X 6 트러스트 와셔 X 6
- Ball Diff Nut X 1 볼 디프 너트 X 1

ST-T64 Super Ball End A (φ4.3)
 슈퍼 볼 엔드 A

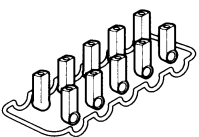

- #4.3 Ball End X 10 볼 엔드 X 10

ST-T65 Super Ball End B (φ5.8)
 슈퍼 볼 엔드 B

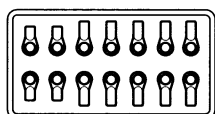

- #5.8 Ball End X 14 볼 엔드 X 14

ST-T66 24mm Wheel (W)
 휠 (백)

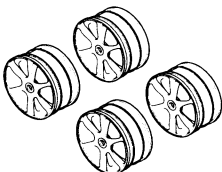

- 24mm Wheel (white) X 4 휠 X 4

ST-T67 24mm Wheel (B)
 휠 (흑)

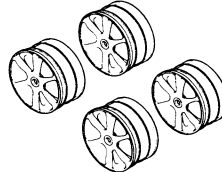

- 24mm Wheel (Black) X 4 휠 X 4

ST-T68 24mm Tire (N30)
 타이어 (N30)

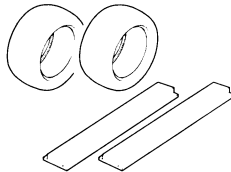

- 24mm Tire(N30) X 2 타이어 X 2
- 24mm Inner Foam X 2 이너 폼 X 2

ST-T69 24mm Tire (N36)
 타이어 (N36)

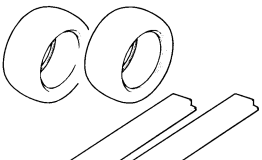

- 24mm Tire(N36) X 2 타이어 X 2
- 24mm Inner Foam X 2 이너 폼 X 2

ST-T70 18mm Turnbuckle
 턴버클

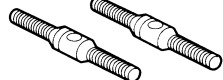

- 18mm AL Turnbuckle X 2 AL 턴버클 X 2

ST-T71 Foam Bumper (STR-4,SP3X)
 폼 범퍼

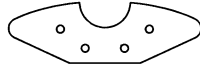

- Foam Bumper X 1 폼 범퍼 X 1

ST-T72 F840 Bush
 F840 부시

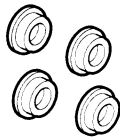

- F840 Bush 부시 X 4

STR-4 부품가격표

코드	품번	알파·베타	텔리	Pro	가격
CPR001	ST-01	○	○		17,000
CPR002	ST-02	○	○	○	5,000
CPR003	ST-03	○	○	○	3,000
CPR004	ST-04	○	○		3,000
CPR005	ST-05	○	○		4,000
CPR006	ST-06	○	○		4,000
CPR007	ST-07	○	○	○	4,000
CPR008	ST-08	○	○		4,000
CPR009	ST-09	○	○	○	5,000
CPR010	ST-010	○	○		2,000
CPR011	ST-011	○	○	○	2,000
CPR012	ST-012	○	○		2,000
CPR013	ST-013	○	○	○	2,500
CPR014	ST-014	○	○		2,000
CPR015	ST-015	○			2,000
CPR016	ST-016	○			3,000
CPR017	ST-017	○	○		2,000
CPR018	ST-018	○	○		3,000
CPR019	ST-019	○	○	○	3,000
CPR020	ST-020	○	○		2,000
CPR021	ST-021	○	○	○	5,000
CPR022	ST-022	○	○	○	1,000
CPR023	ST-023	○		○	4,000
CPR024	ST-024	○	○	○	1,000
CPR025	ST-025	○	○		4,000
CPR026	ST-026	○	○		3,000
CPR027	ST-027	○	○		3,000
CPR028	ST-028	○	○	○	3,500
CPR029	ST-029	○	○		1,000
CPR030	ST-030	○	○		1,000
CPR031	ST-031	○		○	5,000
CPR032	ST-032	○		○	28,000
CPR033	ST-033	○		○	28,000
CPR034	ST-034		○		5,500
CPR035	ST-035		○	○	3,500
CPR036	ST-036		○		5,000
CPR037	ST-037		○		4,000
CPR038	ST-038		○		28,000
CPR039	ST-039	○	○	○	1,500
CPR040	ST-040	○		○	28,000
CPR041	ST-T01	○	○		24,000
CPR042	ST-T02		○		18,000
CPR043	ST-T03	○	○		25,000
CPR044	ST-T04	○		○	5,000
CPR045	ST-T05	○	○	○	6,000
CPR046	ST-T06	○		○	17,000
CPR047	ST-T07	단종			
CPR048	ST-T08	단종			
CPR049	ST-T09	○	○		3,500
CPR050	ST-T10	○	○	○	14,000
CPR051	ST-T11	○	○		7,000
CPR052	ST-T12	○	○		15,000
CPR053	ST-T13	○	○		13,000

코드	품번	알파·베타	텔리	Pro	가격
CPR054	ST-T14	○	○		3,000
CPR055	ST-T15	○	○		2,000
CPR056	ST-T16		○		12,000
CPR057	ST-T17		○		3,000
CPR058	ST-T18		○		1,000
CPR059	ST-T19		○		5,000
CPR060	ST-T20	○	○	○	6,000
CPR061	ST-T21	○	○		15,000
CPR062	ST-T22	○	○		7,000
CPR063	ST-T23	○	○	○	17,000
CPR064	ST-T24	○	○		10,000
CPR065	ST-T25	○	○		13,000
CPR066	ST-T26	○	○	○	5,000
CPR067	ST-T27	○	○	○	5,000
CPR068	ST-T28	○	○	○	4,000
CPR069	ST-T29	○	○	○	4,000
CPR070	ST-T30	○	○	○	4,000
CPR071	ST-T31	○	○	○	4,000
CPR072	ST-T32	○	○	○	4,000
CPR073	ST-T33	○	○	○	4,000
CPR074	ST-T34	○	○	○	4,000
CPR075	ST-T35	○	○		4,000
CPR076	ST-T36	○	○	○	20,000
CPR077	ST-T37	○	○	○	6,000
CPR078	ST-T38	○	○	○	6,000
CPR079	ST-T39	○	○	○	29,000
CPR080	ST-T40	○	○		5,000
CPR081	ST-T41	○	○	○	2,500
CPR082	ST-T42	○	○	○	2,500
CPR083	ST-T43	○	○	○	2,500
CPR084	ST-T44	○	○	○	2,500
CPR085	ST-T45	○	○	○	2,000
CPR086	ST-T46	○	○	○	16,000
CPR087	ST-T47	○	○	○	26,000
CPR088	ST-T48	○	○	○	4,000
CPR089	ST-T49	○	○		20,000
CPR090	ST-T50	○			23,000
CPR091	ST-T51		○		2,000
CPR092	ST-T52		○		17,000
CPR093	ST-T53	○		○	2,000
CPR094	ST-T54	○	○	○	20,000
CPR095	ST-T55	○	○	○	2,000
CPR096	ST-T56	○	○	○	3,000
CPR097	ST-T57	○	○	○	3,000
CPR098	ST-T58	○	○	○	13,000
CPR099	ST-T59	○		○	5,000
CPR100	ST-T60	○	○	○	15,000
CPR101	ST-T61	○			37,000
CPR102	ST-T62	○			28,000
CPR103	ST-T63	○	○	○	5,000
CPR104	ST-T64	○	○	○	2,000
CPR105	ST-T65	○	○	○	2,000
CPR106	ST-T66	○		○	4,000
CPR107	ST-T67	○		○	4,000

코드	품번	알파·베타	텔리	Pro	가격
CPR108	ST-T68	○		○	5,000
CPR109	ST-T69	○		○	5,000
CPR110	ST-T70	○	○	○	3,500
CPR111	ST-T71	○	○	○	4,000
CPR112	ST-T72	○	○	○	1,000
CPR201	ST-P01			○	5,000
CPR202	ST-P02		○	○	3,000
CPR203	ST-P03			○	3,000
CPR204	ST-P04			○	4,000
CPR205	ST-P05			○	2,000
CPR206	ST-P06			○	15,000
CPR207	ST-P07			○	7,000
CPR208	ST-P08			○	37,000
CPR209	ST-P09			○	10,000
CPR210	ST-P10			○	6,000
CPR211	ST-P11			○	1,500
CPR212	ST-P12			○	2,000
CPR213	ST-P13	○	○	○	4,000
CPR214	ST-P14			○	5,000
CPR215	ST-P15			○	3,000
CPR216	ST-P16			○	65,000
CPR217	ST-P17			○	20,000
CPR218	ST-P18			○	10,000
CPR219	ST-P19			○	40,000
CPR220	ST-P20			○	25,000
CP299	GRT-T09	○	○	○	2,500
CP300	GRT-T10	○	○	○	2,500
CP306	GRT-T16	○	○	○	3,500
CP307	GRT-T17	○	○	○	3,500
CP256	GRS-6	○	○		2,500
CP274	GRS-24	○	○	○	2,000
CP275	GRS-25	○	○	○	1,000
CP947	WT-01	○	○	○	6,000
CP972	WT-23	○	○		2,000
CP974	WT-25	○	○	○	1,000
CP778	AS-045	○	○		6,000
CPE046	EXT-16	○	○		3,000
BP723	TRT-3	○	○	○	6,000
BP724	TRT-4	○	○	○	12,000
CPM031	K0501/1	○	○	○	3,000
CPM032	K0501/2	○	○	○	5,000
CPM033	K0501/3	○	○	○	6,500
CPM034	K0501/4	○	○	○	3,500
CPM037	D0508	○	○	○	4,000
CP948	WT-02	○	○	○	7,000
CPM041A	K0603	○	○	○	7,000
CPM192	K1114	○	○	○	2,000
CPM193	K1114S	○	○	○	2,500
CPM194	K1114B	○	○	○	2,000
CPM206	K1116	○	○	○	2,000
CPM208	K1118	○	○	○	2,000
CPM198	K1121	○		○	8,000
CPM087	K1120	○		○	8,000
CP302	GRT-T12	○	○	○	5,000