

PARTS

★製品改良のためキットは予告なく仕様を変更することがあります。
 ★Specifications are subject to change without notice.
 ★Technische Daten können im Zuge ohne Ankündigung verändert werden.
 ★Caractéristiques pouvant être modifiées sans information préalable.

A PARTS ×2 51002

★Aパーツは2枚組ですが、1枚はA1~7、14までしかありません。
 ★Kit includes two "A" sprues - one whole A sprue and one more sprue that contains parts A1-7 and A14.
 ★Der Bausatz beinhaltet zwei "A"-Spritzlinge - einen vollständigen A-Spritzling und einen weiteren, der die Teile A1-7 und A14 enthält.
 ★La boîte contient 2 grappes "A": une complète et une ne contenant que les pièces A1 à A7 et A14.

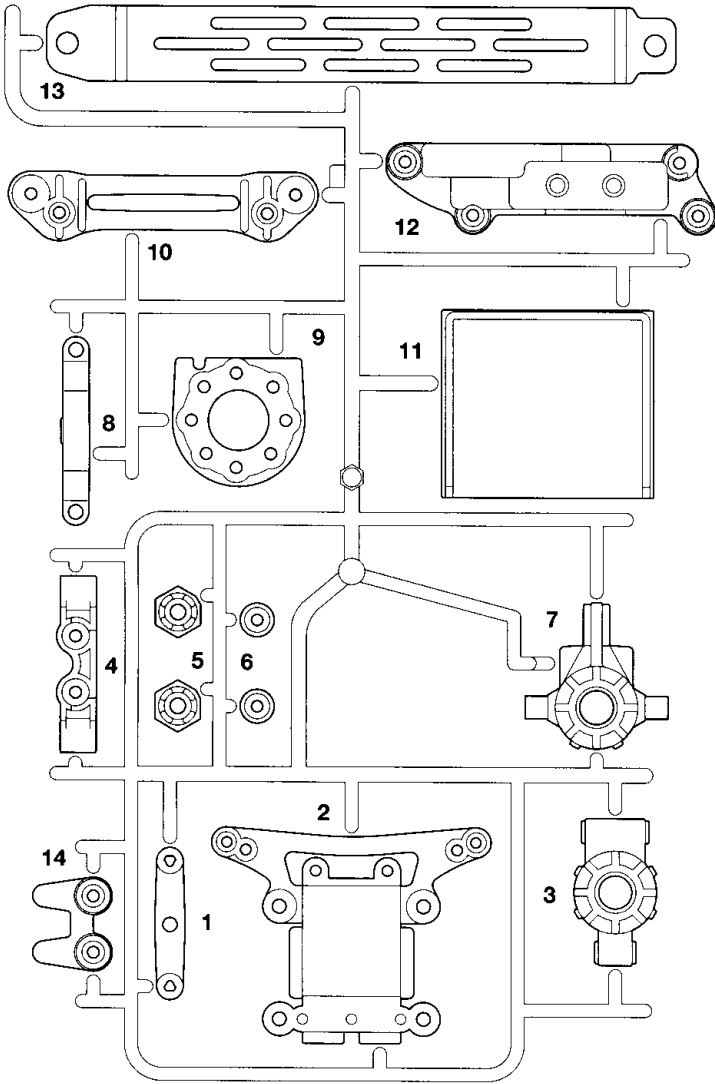

B PARTS ×2 51003

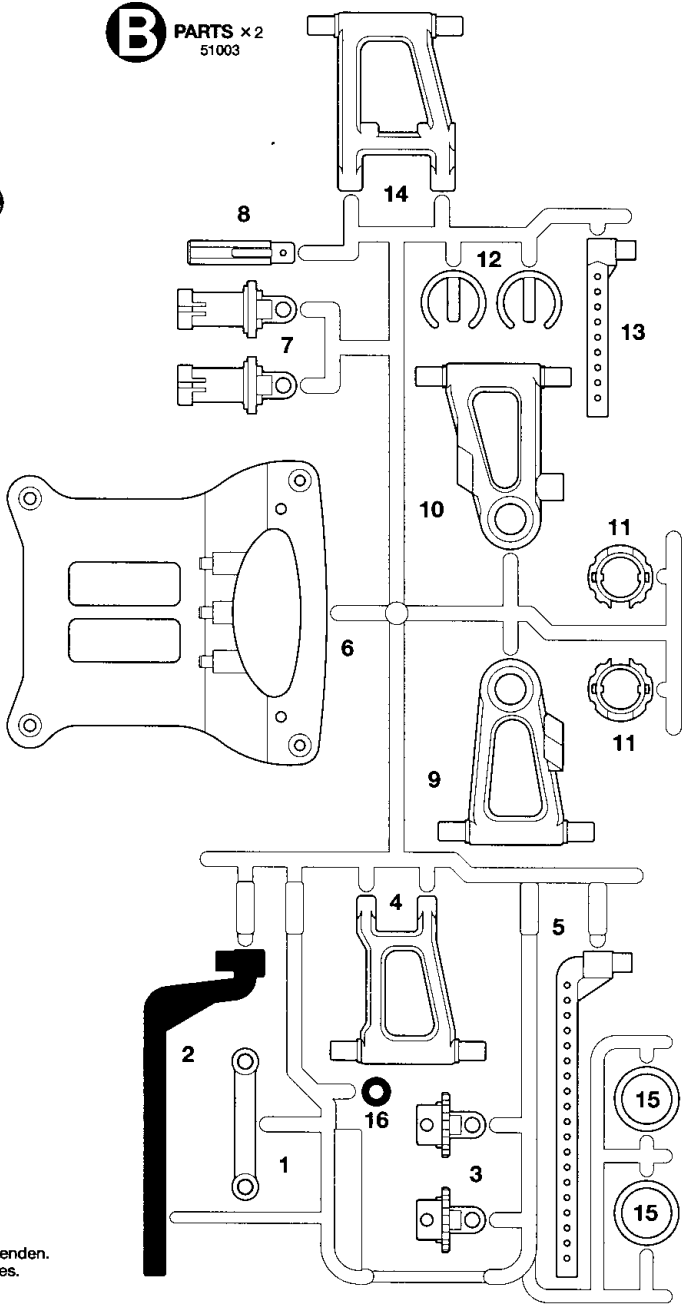

D PARTS ×1 9005719

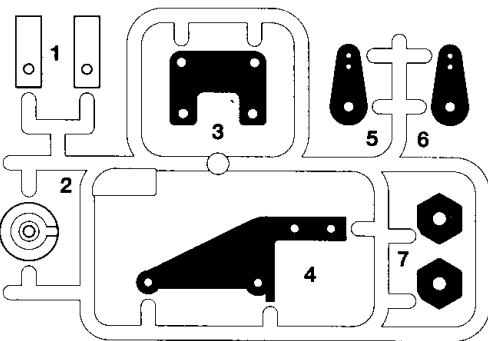

■ 不要部品
 Not used.
 Nicht verwenden.
 Non utilisées.

P PARTS ×1 51005

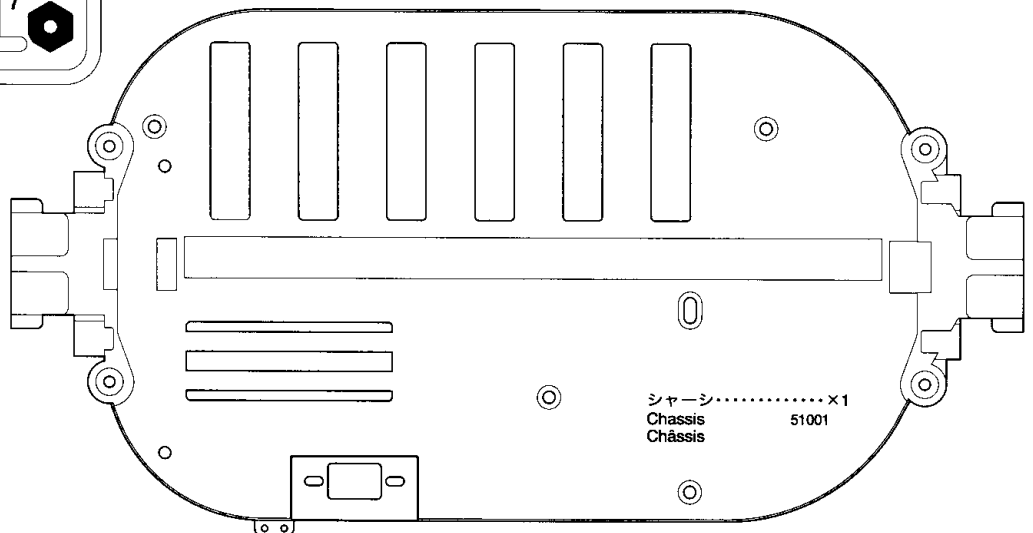
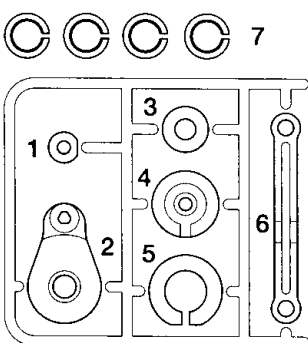

シャーシ.....×1
 Chassis 51001
 Châssis

PARTS

★金具部品は少し多めに入っています。予備として使ってください。
 ★Extra screws and nuts are included. Use them as spares.
 ★Ersatzschrauben und -muttern liegen bei.
 ★Des vis et des écrous supplémentaires sont inclus. Les utiliser comme pièces de rechange.

H PARTS ×1
9005705

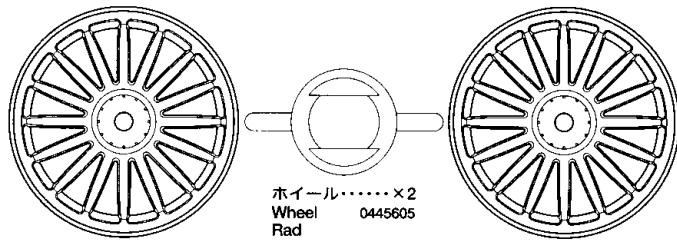
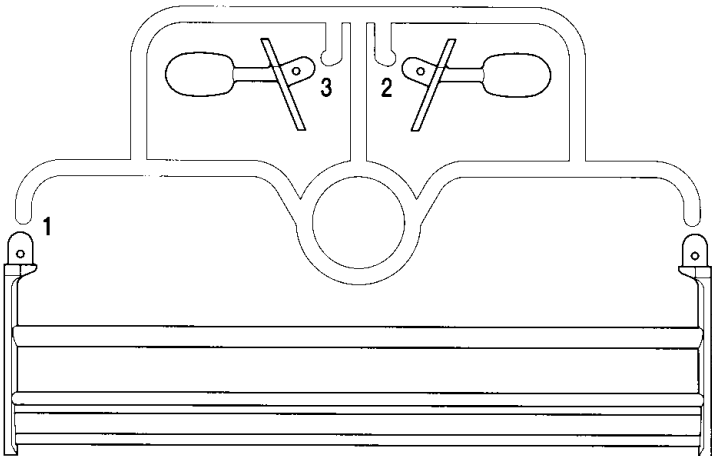

ホイール.....×2
Wheel 0445605
Rad
Roue

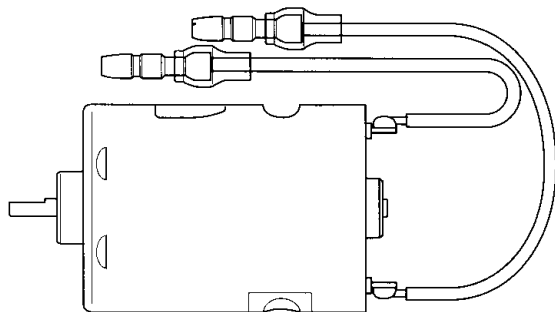

モーター.....×1
Motor 7435035
Moteur

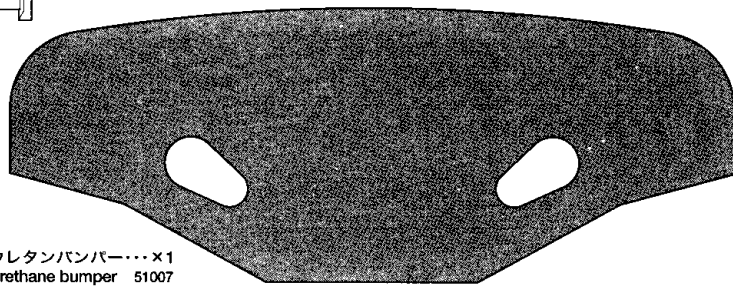

ウレタンバンパー.....×1
Urethane bumper 51007
Urethan-Stoßfänger
Pare-chocs en mousse

ボディ.....×1
Body 1825252
Karosserie
Carrosserie

ステッカー⑨.....×1
Sticker 9804169
Aufkleber
Autocollant

タイヤ.....×4
Tire 50454
Reifen
Pneu

アンテナパイプ.....×1
Antenna pipe 6095003
Antennenrohr
Gaine d'antenne

ステッカー⑩.....×1
Sticker 9804169
Aufkleber
Autocollant

ホイールシャフト袋詰 9005713
Shaft bag
Achsen-Beutel
Sachet d'arbres

SB1 ×1 プロペラシャフト
Propeller shaft
Antriebswelle
Arbre de transmission

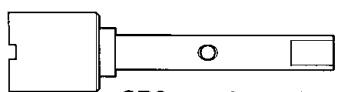
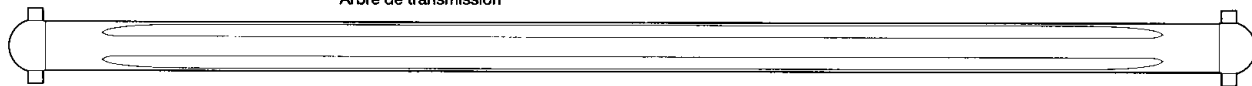

SB2 ×1 リアプロペラジョイント
Rear propeller joint
Hinteres Antriebs-Gelenk
Accouplement d'arbre de transmission arrière

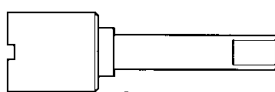

SB3 ×1 フロントプロペラジョイント
Front propeller joint
Vorderes Antriebs-Gelenk
Accouplement d'arbre de transmission avant

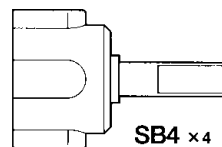

SB4 ×4 ギヤボックスジョイント
Gearbox joint
Getriebegehäuse-Gelenk
Accouplement de pont 51006

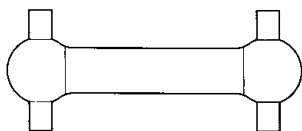

SB5 ×4 ドライブシャフト
Drive shaft
Achswelle
Arbre d'entraînement 51006

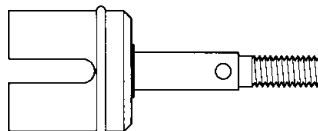

SB6 ×4 ホイールアクスル
Wheel axle
Radachse
Axe de roue 51006

ギヤ袋詰 51004
Gear bag
Zahnräder-Beutel
Sachet de pignonerie

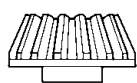

GB1 ×2 ベベルピニオンギヤ
Bevel pinion gear
Kegelritzel
Pignon conique

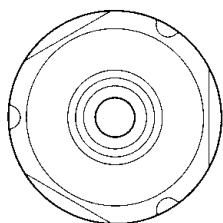

GB3 ×2 デフキャリア
Differential gear case
Differentialgehäuse
Carter de différentiel

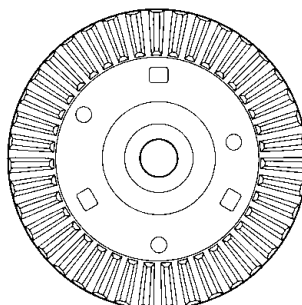

GB4 ×2 リングギヤ
Ring gear
Tellerrad
Couronne

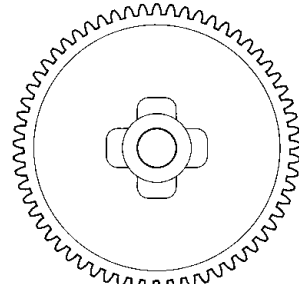

GB5 ×1 61Tスパーギヤ
61T Spur gear
61Z Stirradgetriebe
Pignon intermédiaire 61 dents

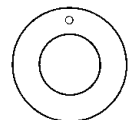

GB2 ×1 スパーギヤストッパー
Spur gear stopper
Stirnrad-Mitnehmer
Cale de pignon intermédiaire

ベアリング袋詰
 Bearing bag
 Lager-Beutel
 Sachet de Paliers



RB1 1150プラベアリング
 ×12
 0555015
 Plastic bearing
 Plastik-Lager
 Palier en plastique



RB2 1280メタル
 ×4
 Metal bearing
 Metall-Lager
 Palier en métal

A ①~⑪

9415977

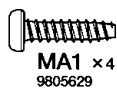

MA1 ×4
 9805629
 3×12mmタッピングビス
 Tapping screw
 Schneidschraube
 Vis taraudeuse

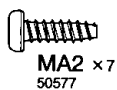

MA2 ×7
 50577
 3×10mmタッピングビス
 Tapping screw
 Schneidschraube
 Vis taraudeuse

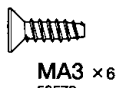

MA3 ×6
 50578
 3×10mmⅢタッピングビス
 Tapping screw
 Schneidschraube
 Vis taraudeuse



MA4 ×2
 9805636
 3×6mm丸ビス
 Screw
 Schraube
 Vis

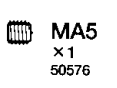

MA5 ×1
 50576
 3mmイモネジ
 Grub screw
 Madenschraube
 Vis pointeau



2×8mmタッピングビス
 Tapping screw
 Schneidschraube
 Vis taraudeuse
MA6 ×3
 50573

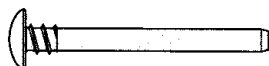

MA7 ×2
 9805756
 3×32mmスクリューピン
 Screw pin
 Schraubzapfen
 Cheville à vis

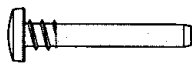

MA8 ×2
 9805755
 3×22mmスクリューピン
 Screw pin
 Schraubzapfen
 Cheville à vis



2×10mmシャフト
 Shaft
 Achse
 Axe
MA9 ×1
 50594



MA10 ×1
 50355
 19Tピニオンギヤ
 19T Pinion gear
 19Z Motorzitzel
 Pignon moteur 19 dents

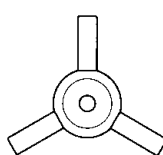

MA11 ×1
 51008
 ベベルシャフト
 Star shaft
 Stern-Achse
 Support de satellite



MA12 ×2
 51008
 ベベルギヤ (大)
 Large bevel gear
 Kegelrad groß
 Grand pignon conique



MA13 ×3
 51008
 ベベルギヤ (小)
 Small bevel gear
 Kegelrad klein
 Petit pignon conique

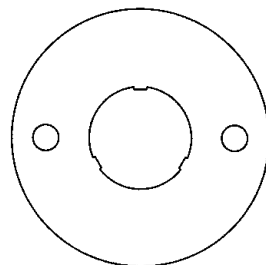

MA14 ×1
 4305125
 モータープレート
 Motor plate
 Motor-Platte
 Plaque-moteur

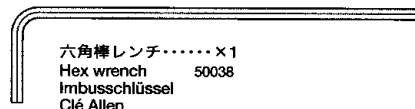

六角棒レンチ.....×1
 Hex wrench 50038
 Imbusschlüssel
 Clé Allen

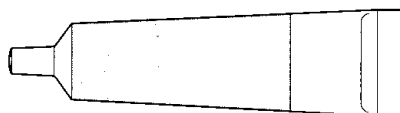

グリス.....×1
 Grease 87025
 Fett
 Graisse

B ⑫~⑳

9415978



MA1 ×2
 9805629
 3×12mmタッピングビス
 Tapping screw
 Schneidschraube
 Vis taraudeuse

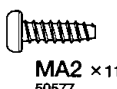

MA2 ×11
 50577
 3×10mmタッピングビス
 Tapping screw
 Schneidschraube
 Vis taraudeuse

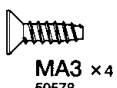

MA3 ×4
 50578
 3×10mmⅢタッピングビス
 Tapping screw
 Schneidschraube
 Vis taraudeuse



2×8mmタッピングビス
 Tapping screw
 Schneidschraube
 Vis taraudeuse
MA6 ×3
 50573

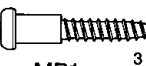

MB1 ×2
 9805573
 3×18mm段付ビス
 Step screw
 Paßschraube
 Vis décollée

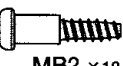

MB2 ×12
 50582
 3×14mm段付ビス
 Step screw
 Paßschraube
 Vis décollée



3mmワッシャー
 Washer
 Beilagscheibe
 Rondelle
MB3 ×2
 50586

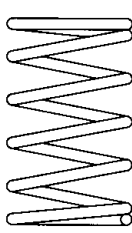

MB4 ×4
 9805699
 コイルスプリング
 Coil spring
 Spiralfeder
 Ressort hélicoïdal

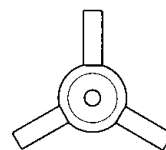

MA11 ×1
 51008
 ベベルシャフト
 Star shaft
 Stern-Achse
 Support de satellite



MA12 ×2
 51008
 ベベルギヤ (大)
 Large bevel gear
 Kegelrad groß
 Grand pignon conique



MA13 ×3
 51008
 ベベルギヤ (小)
 Small bevel gear
 Kegelrad klein
 Petit pignon conique

C ㉔~㉙

9415979

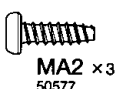

MA2 ×3
 50577
 3×10mmタッピングビス
 Tapping screw
 Schneidschraube
 Vis taraudeuse

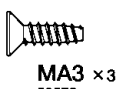

MA3 ×3
 50578
 3×10mmⅢタッピングビス
 Tapping screw
 Schneidschraube
 Vis taraudeuse

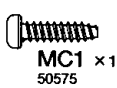

MC1 ×1
 50575
 2.6×10mmタッピングビス
 Tapping screw
 Schneidschraube
 Vis taraudeuse

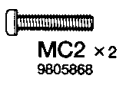

MC2 ×2
 9805868
 2×10mm丸ビス
 Screw
 Schraube
 Vis

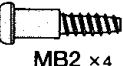

MB2 ×4
 50582
 3×14mm段付ビス
 Step screw
 Paßschraube
 Vis décollée



3mmワッシャー
 Washer
 Beilagscheibe
 Rondelle
MB3 ×2
 50586



2mmワッシャー
 Washer
 Beilagscheibe
 Rondelle
MC3 ×2
 9805758



MC4 ×4
 9805557
 4mmフランジロックナット
 Flange lock nut
 Sicherungsmutter
 Ecrou nylstop à flasque

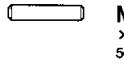

2×10mmシャフト
 Shaft
 Achse
 Axe
MA9 ×4
 50594

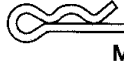

スナップピン (小)
 Snap pin (small)
 Federstift (klein)
 Epingle métallique (petite)
MC5 ×4
 50197



スナップピン (大)
 Snap pin (large)
 Federstift (groß)
 Epingle métallique (grande)
MC6 ×2
 50197

ナイロンバンド.....×2
 Nylon band 50595
 Nylonband
 Collier nylon

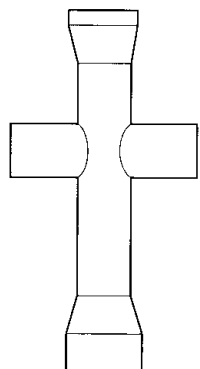

両面テープ.....×1
 Double-sided tape 50171
 Doppelklebeband
 Adhésif double face

十字レンチ.....×1
 Box wrench 50038
 Steckschlüssel
 Clé à tube

D ㉓~㉗

9400074



MD1 ×4
 9805240
 3mmOリング (黒)
 O-ring (black)
 O-Ring (schwarz)
 Joint torique (noir)



MC5 ×8
 50197
 スナップピン (小)
 Snap pin (small)
 Federstift (klein)
 Epingle métallique (petite)

