

1/10 SCALE EP 4WD TOURING CAR

ACADEMY

HOBBY MODEL KITS

STR-4

오아세이인포

INSTRUCTION MANUAL 제품 설명서

5MG
SHAFT DRIVE SYSTEM

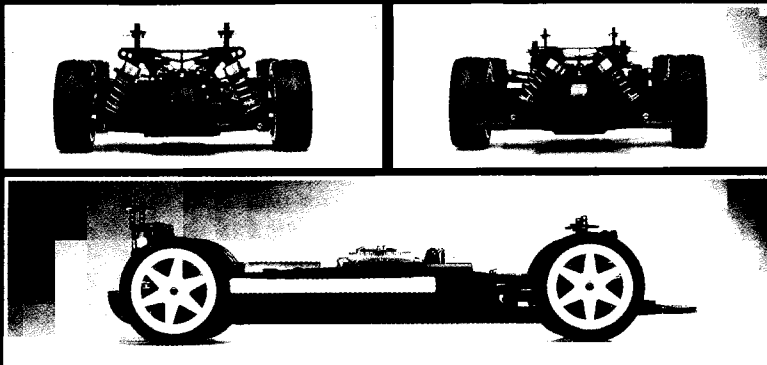
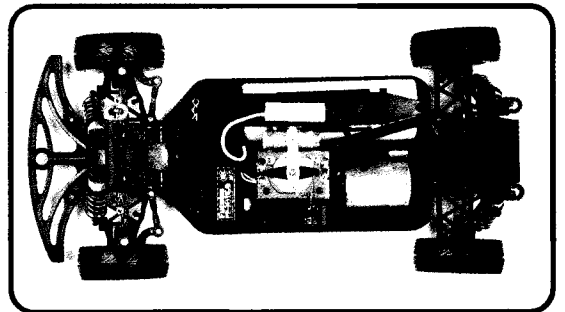
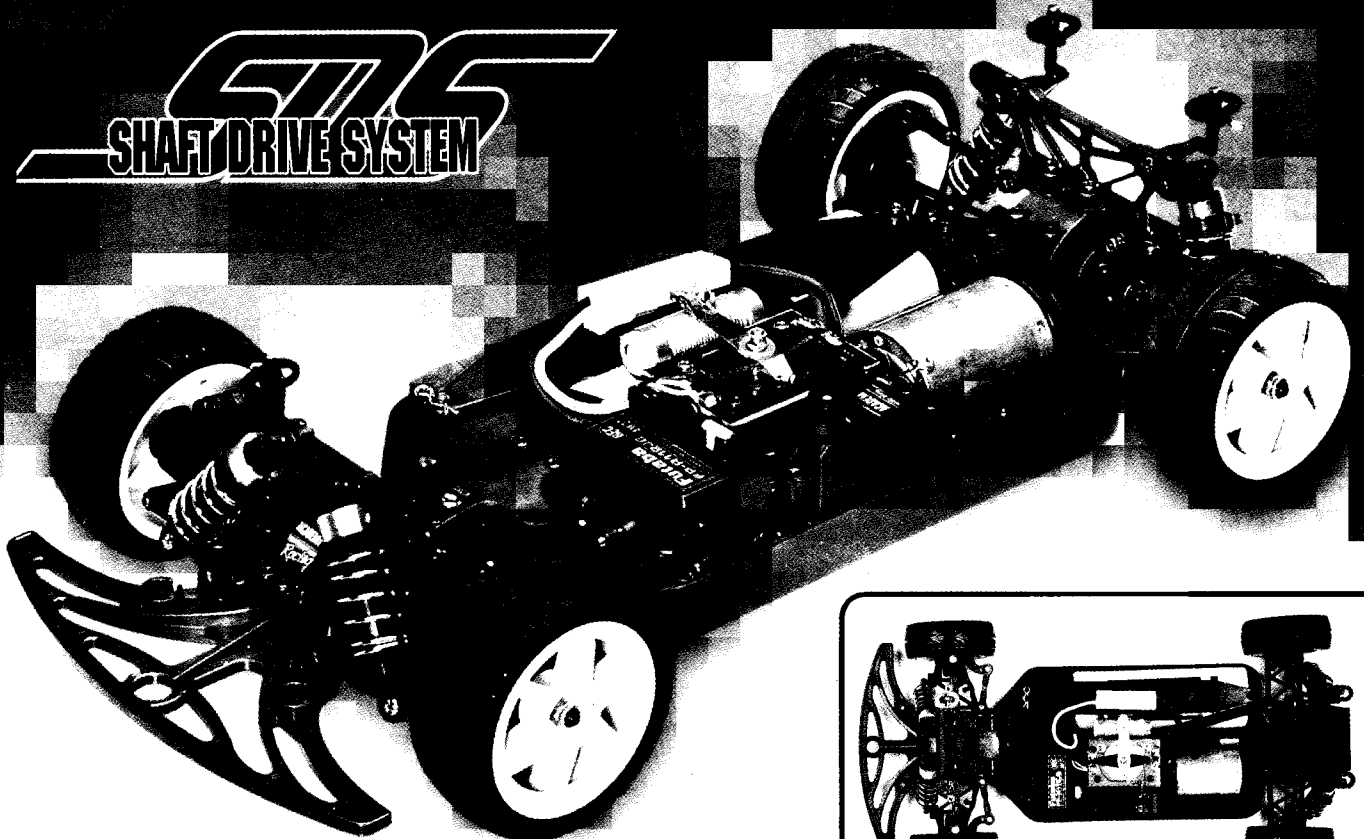

TECHNICAL DATA(제원)

▶ Width 전폭	187mm
▶ Wheel Base 휠베이스	257mm
▶ Tread(F/R) 트레드	161mm/161mm
▶ Weight 전장비 중량	1400g
▶ Caster(F/R) 캐스터(전/후)	9°·15° / 3°
▶ Rear Toe-in 후륜 토-인	2°
▶ Internal Drive Ratio 내부기어비	3.18:1

- Independent 4 wheel suspension with double wishbones.
- Available to use both type of stick packs or saddle packs battery.
- Body, RS540S motor, speed controller included.
- Shaft-drive transmission 4WD system.
- One-piece molded chassis.
- Bevel type diff. gear.
- Lowest center of gravity.
- 2° angle for bottom of chassis.

- 4륜 샤프트 드라이브 트랜스미션 시스템
- 더블 위시본 타입 4륜 독립 현가 방식
- 일체형 몰드 샤프트
- 베벨 타입 디퍼런셜 기어
- 최저의 무게 중심 설계
- 스틱 타입 및 새들 타입 배터리 사용가능
- 샤프트 바닥의 2° 경사각 채용

1

아카데미제품을 구입해 주셔서 감사합니다. 새시가 90% 완성 상태인 STR-4는 완성시키기 위해서는 약간의 최종작업을 요합니다. 조립을 시작하기전에 설명서를 충분히 읽어보아야 합니다. 작업도중 부상을 방지하기 위해 주의가 필요합니다.

Thank you for your purchase ACADEMY products. The Kit is semi-assembled, and is required to do some final fobs for completion. Be sure to read the instructions fully before commencing the assembly. Cares should be taken to avoid any injuries during the works.

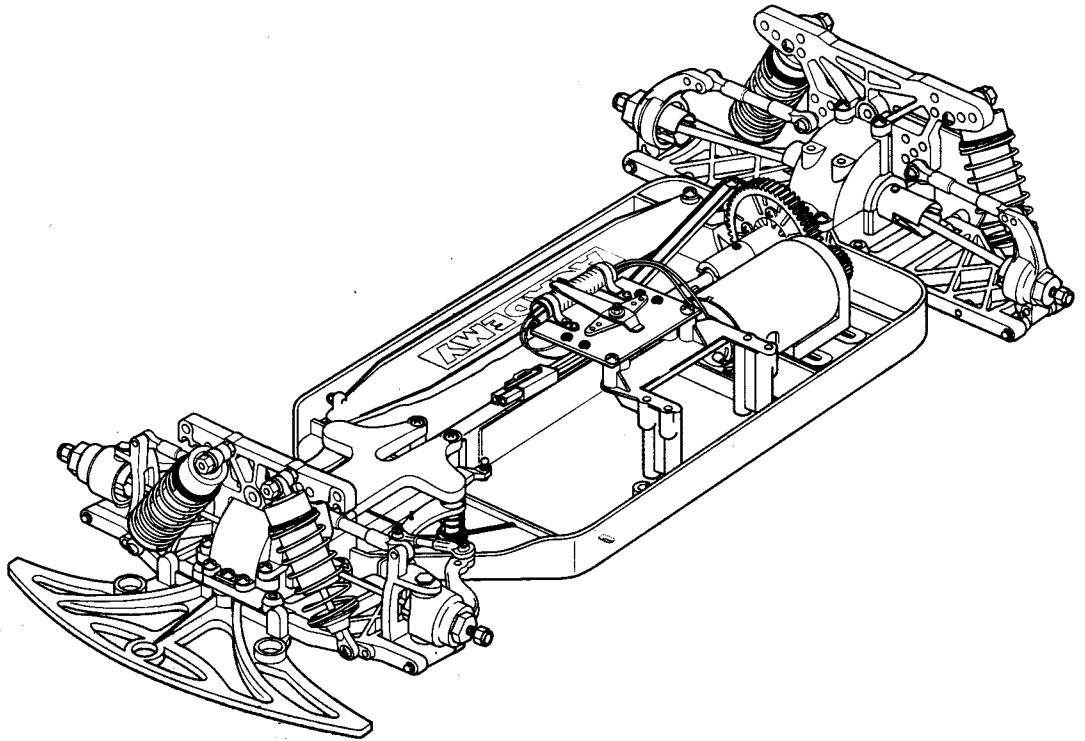

2



Hook pin 2
후크핀



Ø3×12 P/H₂
Tapping screw 2
비스

뒤편 새시에서 분해한 후 Page5-④의 그림과 같은 요령으로 오일을 주입 후 새시에 다시 결합한다.

After disassembling damper from chassis, inject oil into it as the same way as illustrated in the drawing Page5-④ and assemble it again to chassis.

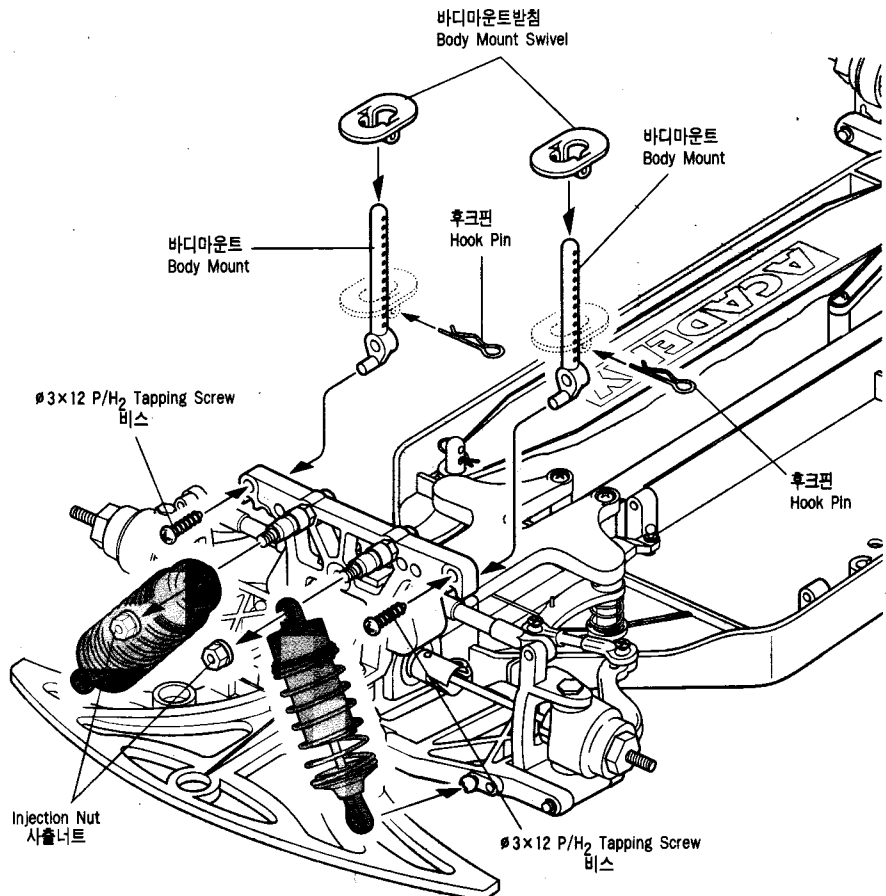

3



Hook pin 2
후크핀

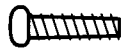

Ø3×12 P/H₂
Tapping screw 2
비스

편퍼는 새시에서 분해한 후 Page5-④
그림과 같은 방법으로 오일을 주
입 후 새시에 다시 결합한다.

After disassembling damper from
chassis, inject oil into it as the
same way as illustrated in the
drawing Page5-④ and assemble it
again to chassis.

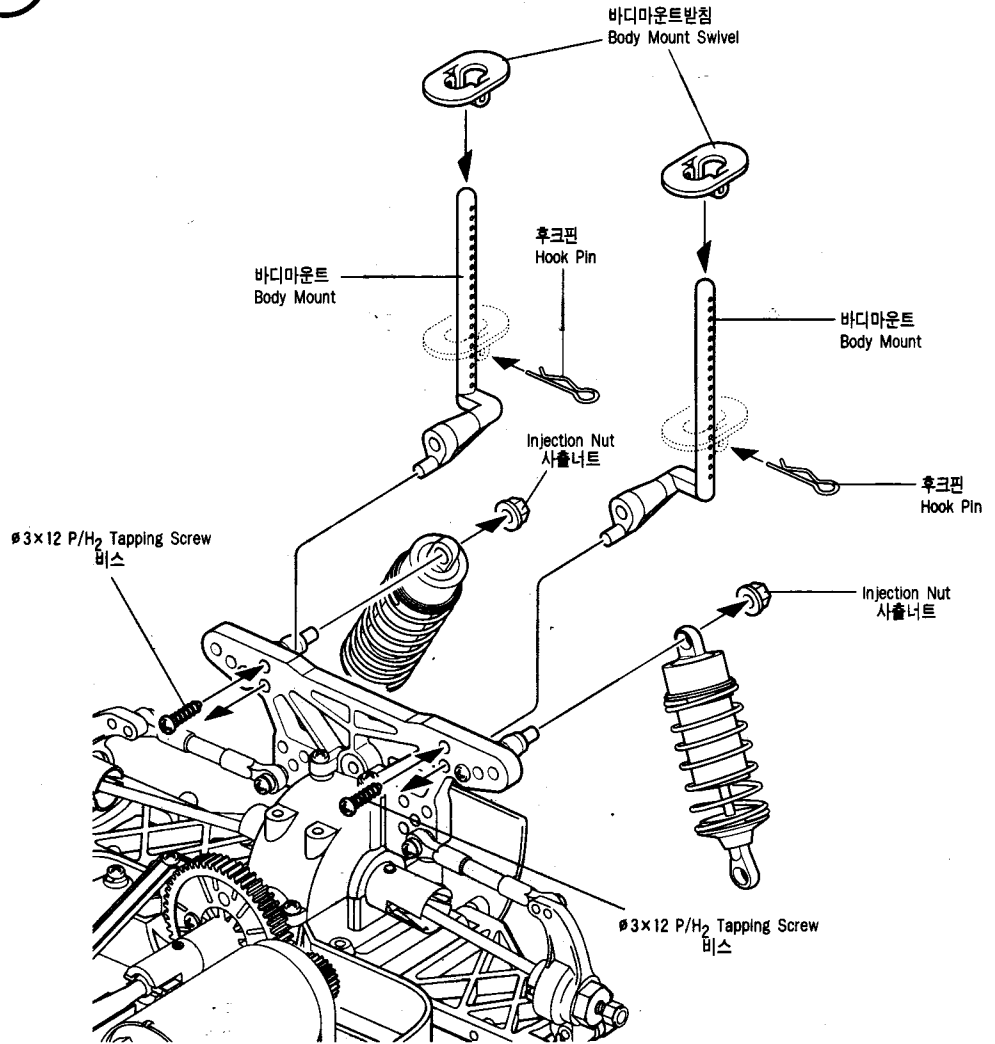

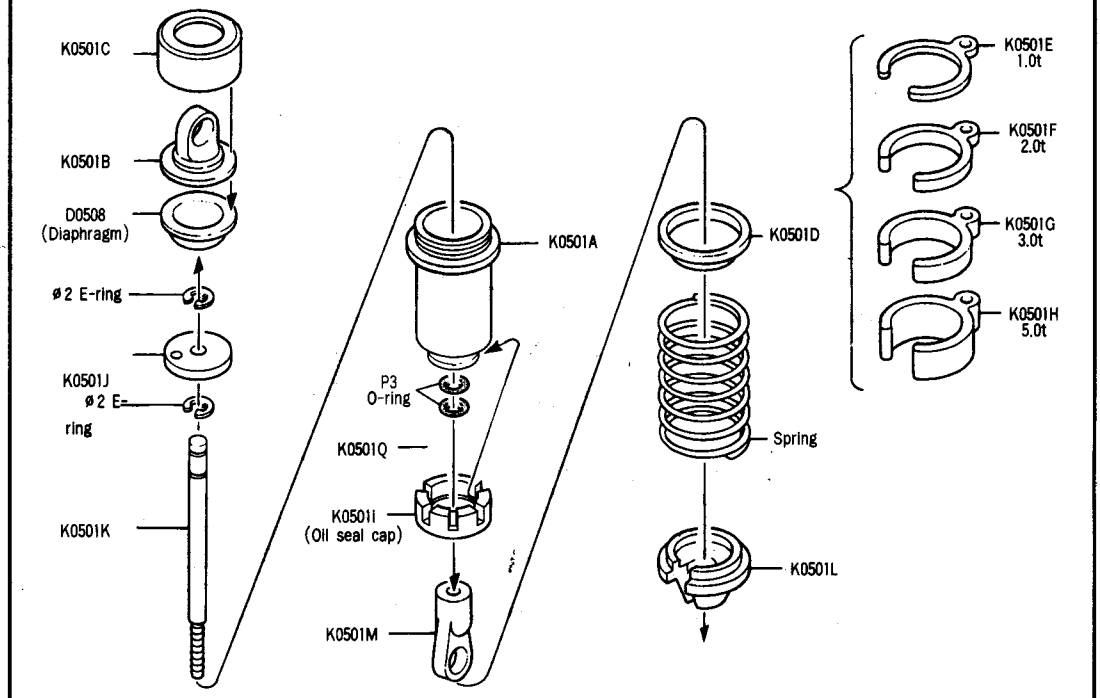

〈댐퍼분해도〉 Damper Exploded View

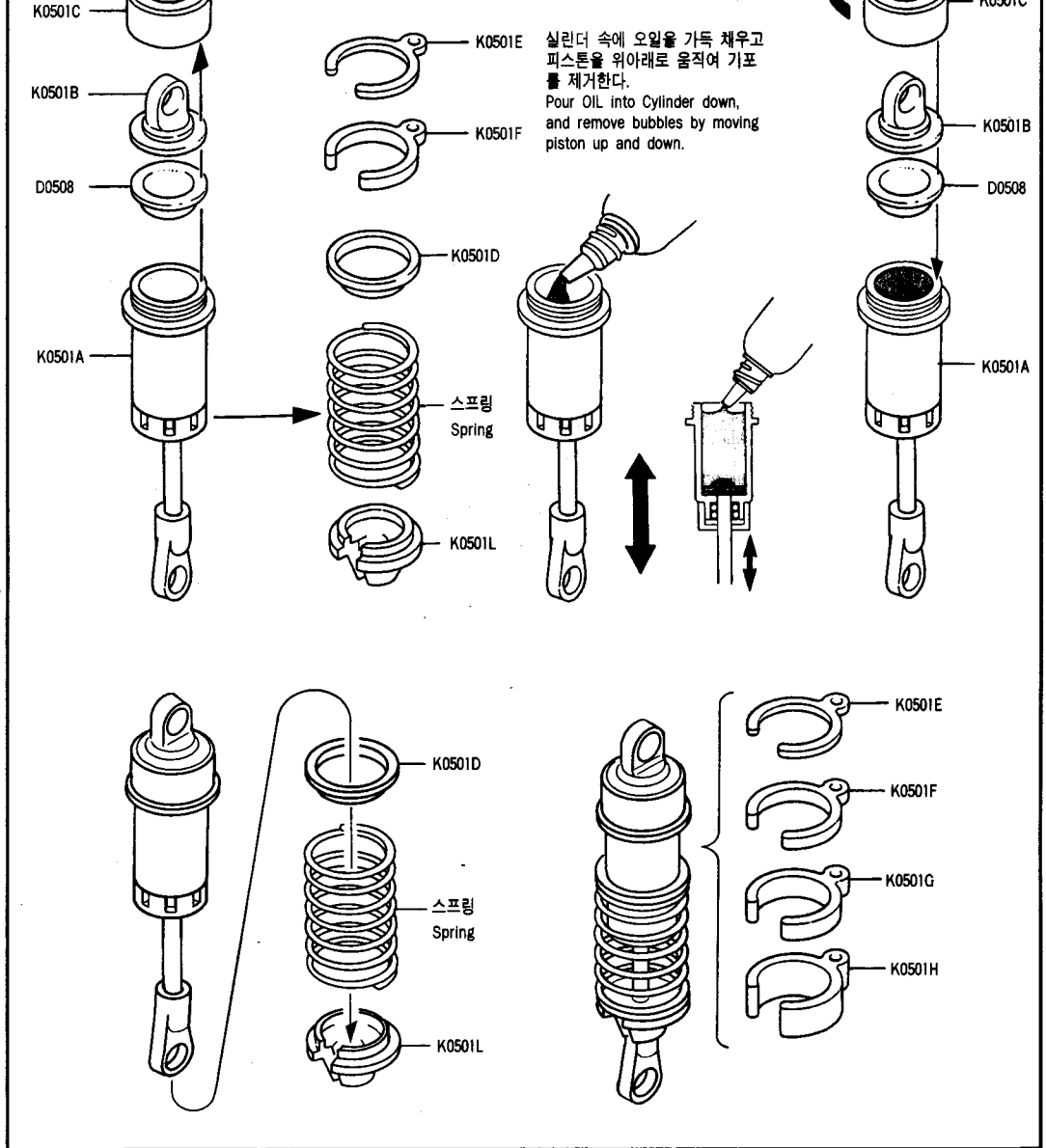

4

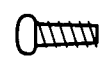

- 
 Ø2.6×10 P/H₂
 Tapping screw 1
 비스
- 
 Ø3×8 P/H₂
 Tapping screw 2
 비스
- 
 Ø4.3 Pin ball 1
 핀볼

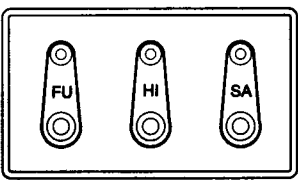

FUTABA 후다바 HITEC 하이텍 SANWA 산와

5

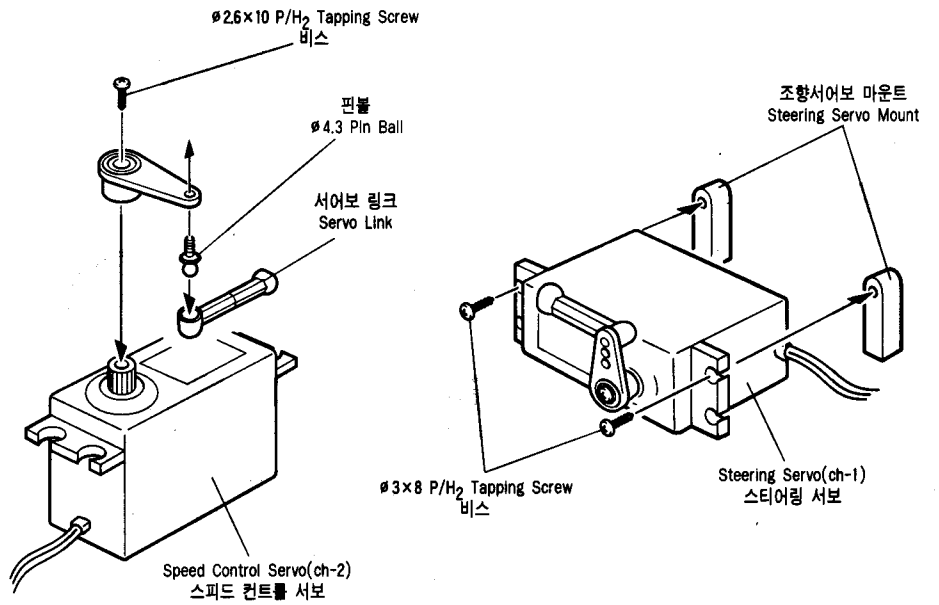



Ø3×10 F/H₂
Tapping screw 2
접시비스

6

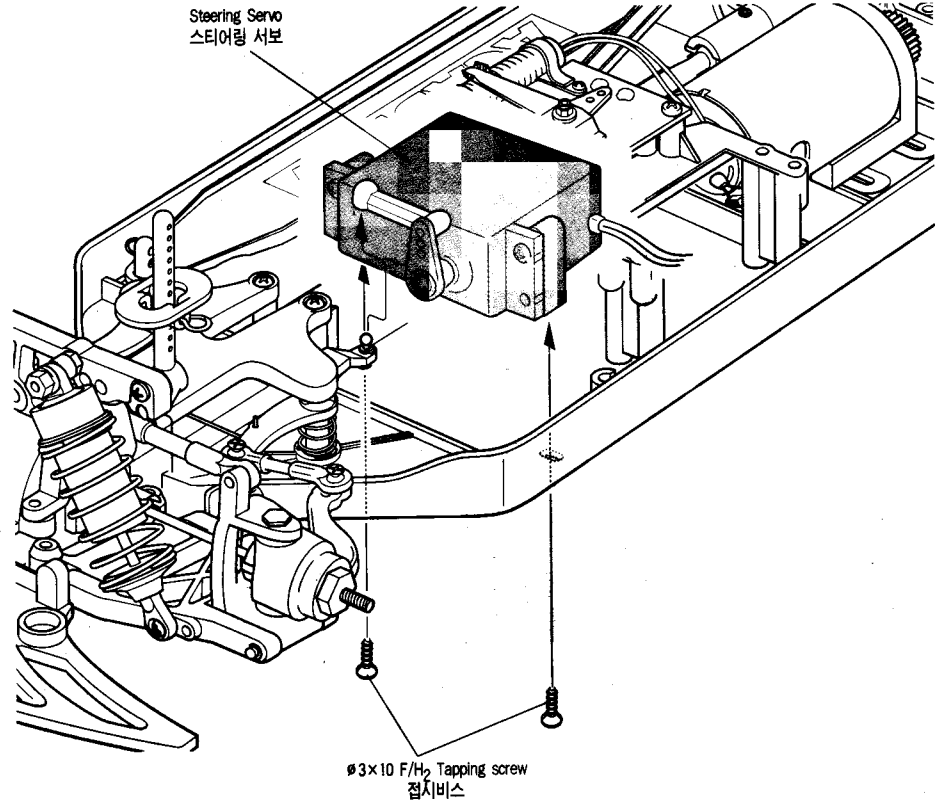

7



Ø3×8 P/H₂
Tapping screw 4
비스

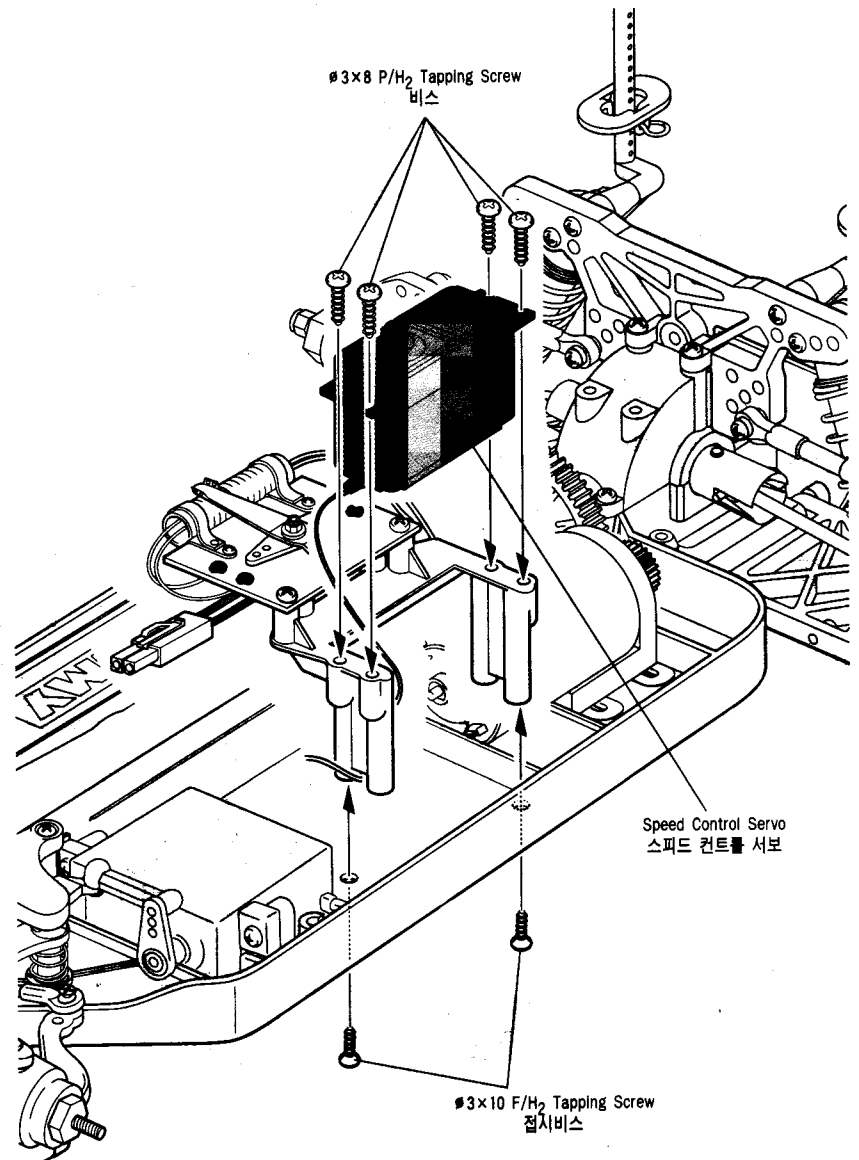

8

양면테이프는 적당한 크기로 잘라서 사용한다.
Double-sided tape is used to cut in proper sizes.

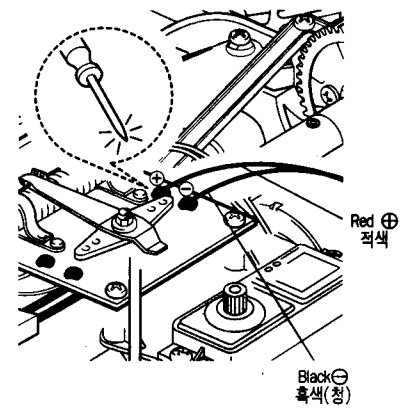
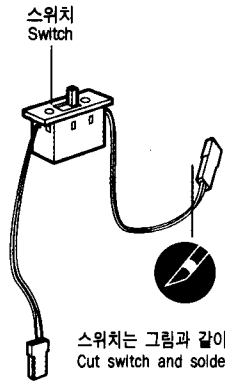
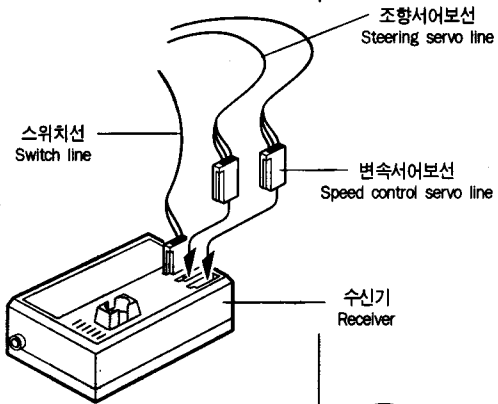
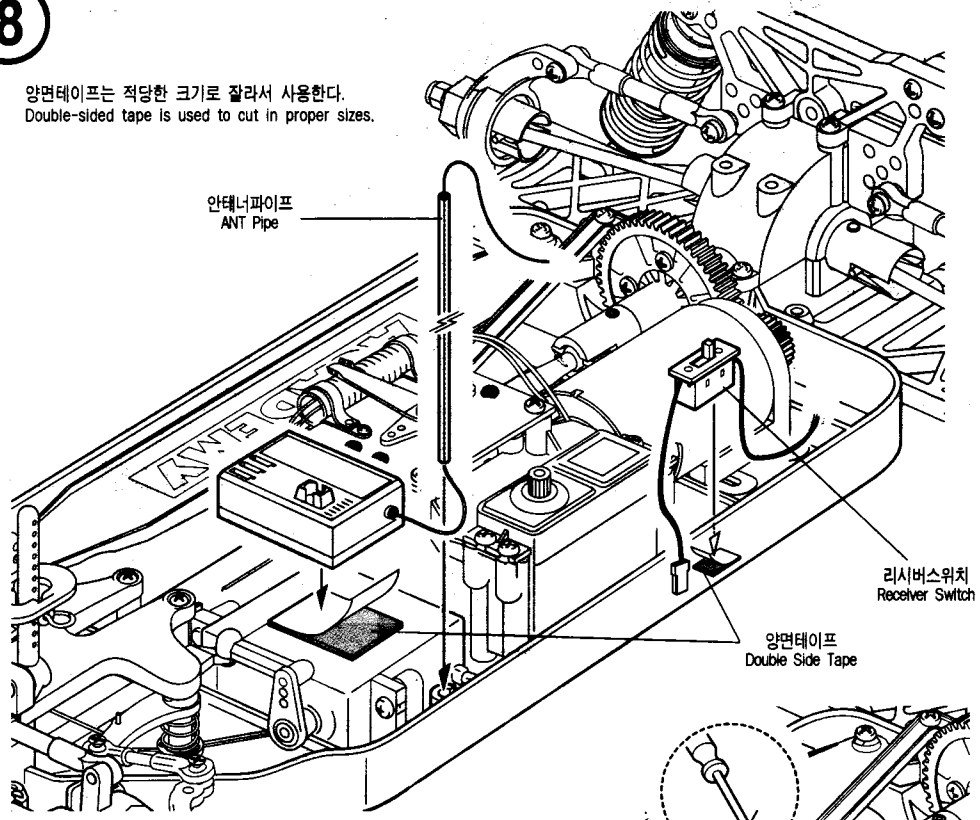

스위치는 그림과 같이 자른 후 ⊕ ⊖을 잘 확인 후 옆의 그림과 같이 납땀한다.
Cut switch and solder it as in the drawing taking notice of the polarity(⊕, ⊖).

9

배터리스페이스의 위치를 이동하여 차량의 무게중심을 변화시킬 수 있다.
The balance of weight for a car can be changed by he place of battery spacer.

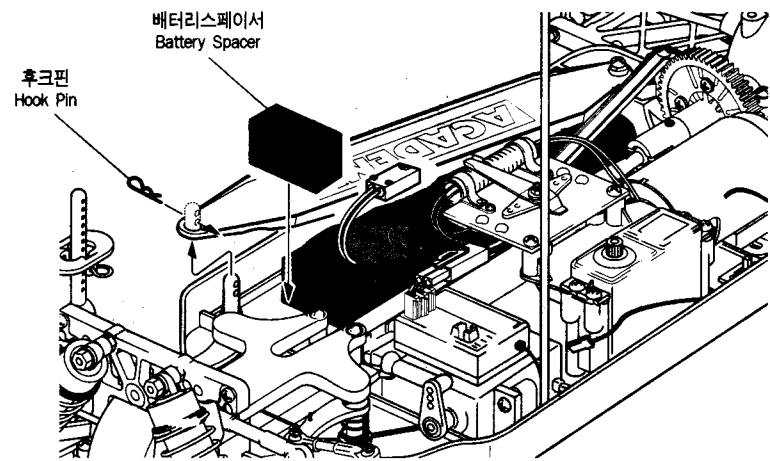
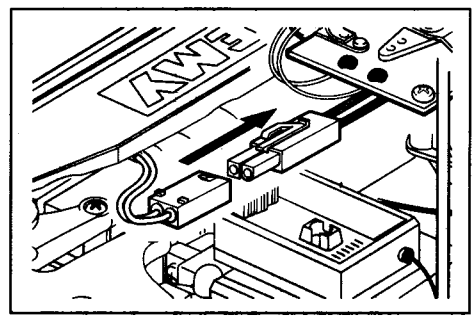
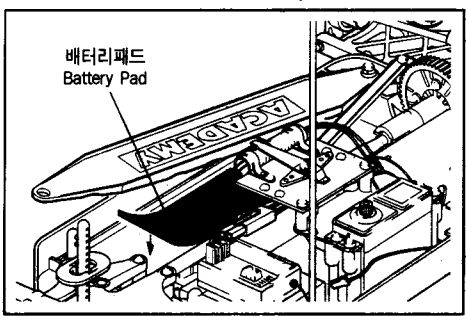

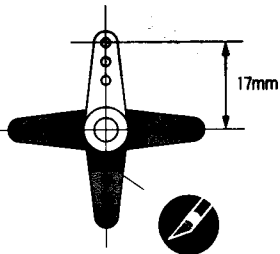

Speed control rod(Black) 1
스피드콘트롤로드(흑색)

조종기와 수신기를 켜고 전후진이
원활하게 되는지 확인한다.

Switch on transceiver and receiver
to check if the forward or
backward is working smoothly.

10

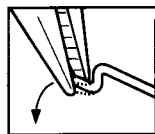

Bend the rod left as shown.
그림과 같이 왼쪽으로 구부린다.

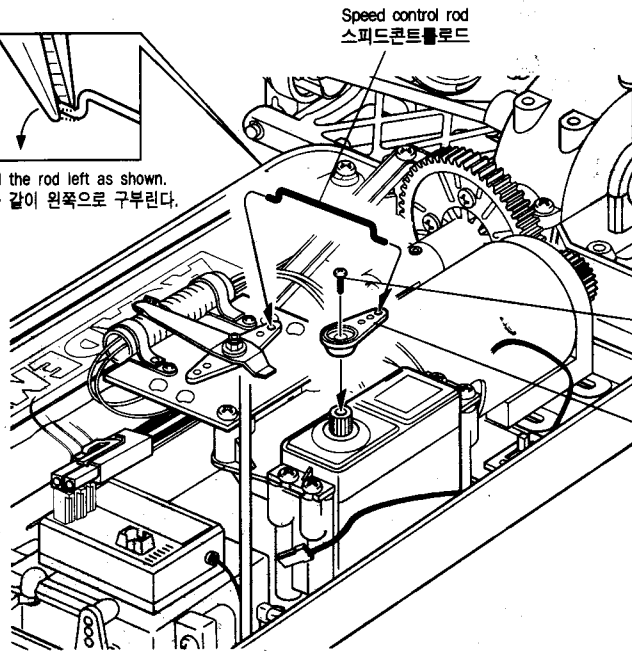

Speed control rod
스피드콘트롤로드

조종기세트에 포함되어 있는 비스
Propo-Set Screw

서어보흔
Servo Horn

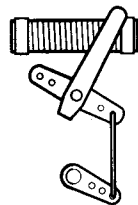

Forward
전진

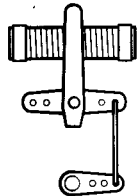

Stop
정지

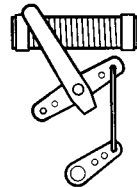

Revers
후진

11

4

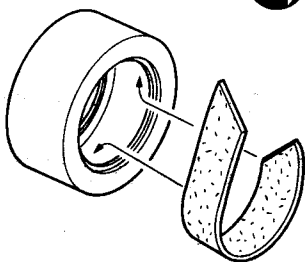

타이어 속에 인너스폰지를 넣는다.
Insert inner-sponge inside of tire.

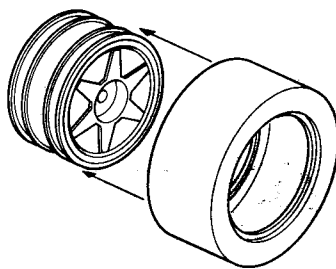

타이어 속으로 휠을 넣는다.
Wheel to be forced into tire.

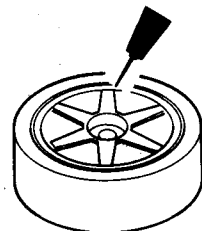

ø4 Nylon nut 4
나일론너트

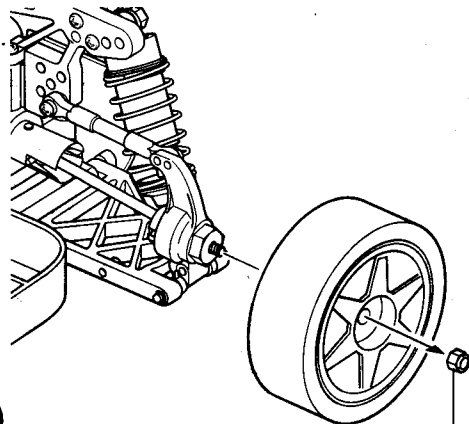
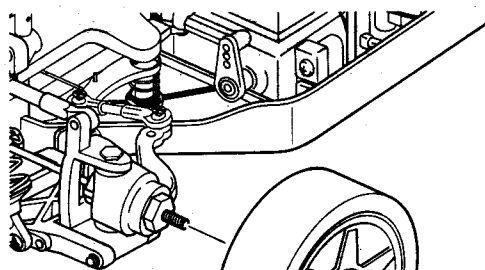

ø4 Nylon nut
나일론너트

ø4 Nylon nut
나일론너트

12

*바디를 다듬기 전에 차체에 올려서 마운트 구멍의 위치를 맞춰 본다.

Before cutting and making holes on the Body, put unpainted Body on the Chassis and confirm position.

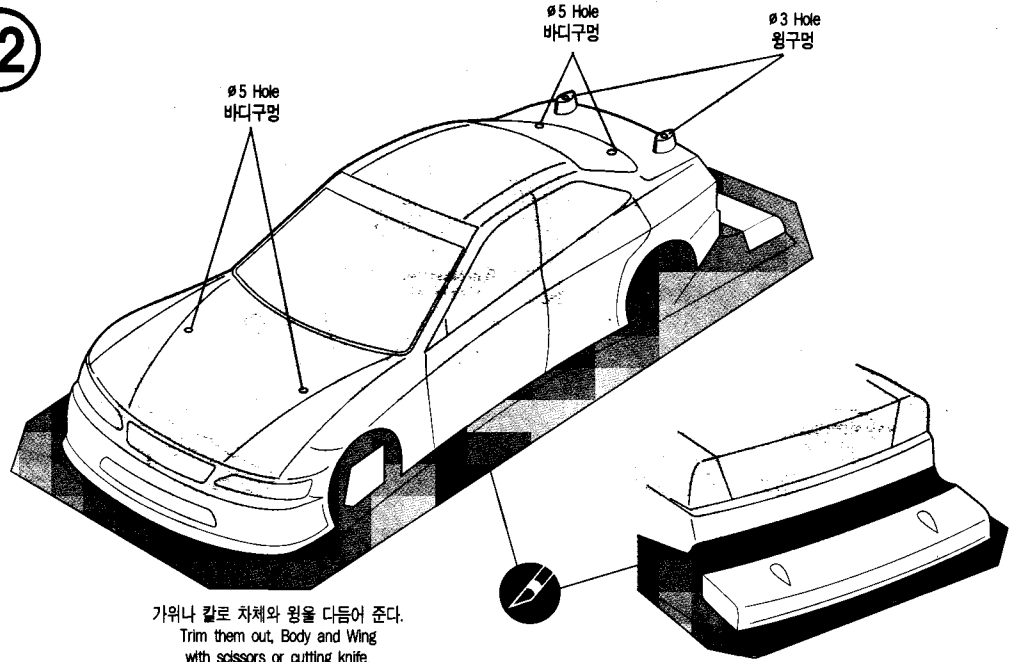

가위나 칼로 차체와 윙을 다듬어 준다.
Trim them out, Body and Wing with scissors or cutting knife.

색칠전에 중성세제로 내부를 씻어준다.
Before painting, wash inside with neutral detergent.

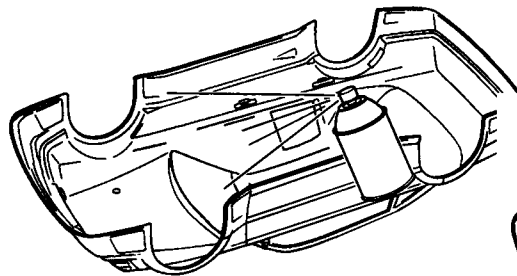

창문에 마스킹을 한 후 폴리카보네이트 페인트를 칠해 준다.
Apply polycarbonate painting after masking off windows.

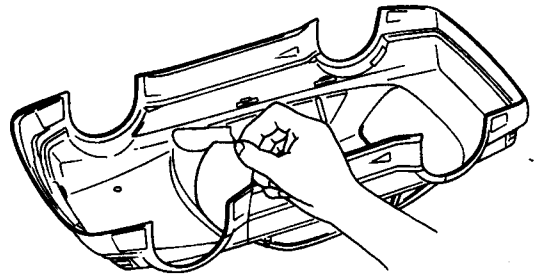

색칠이 마르면 마스킹과 보호 필름을 벗겨낸다.
When paintings are dried out, peel off masking and protective films.

NOTICE (참고)

Attach the decals as you want.

스티커는 상지그림을 참조하여 임의대로 붙인다.

13

양면 테이프는 적당한 크기로 잘라서 사용한다
Double-Sided tape is used to cut in proper sizes



Ø3×6 B/H Screw 2 바인드볼트



Ø3 Nut 2 너트

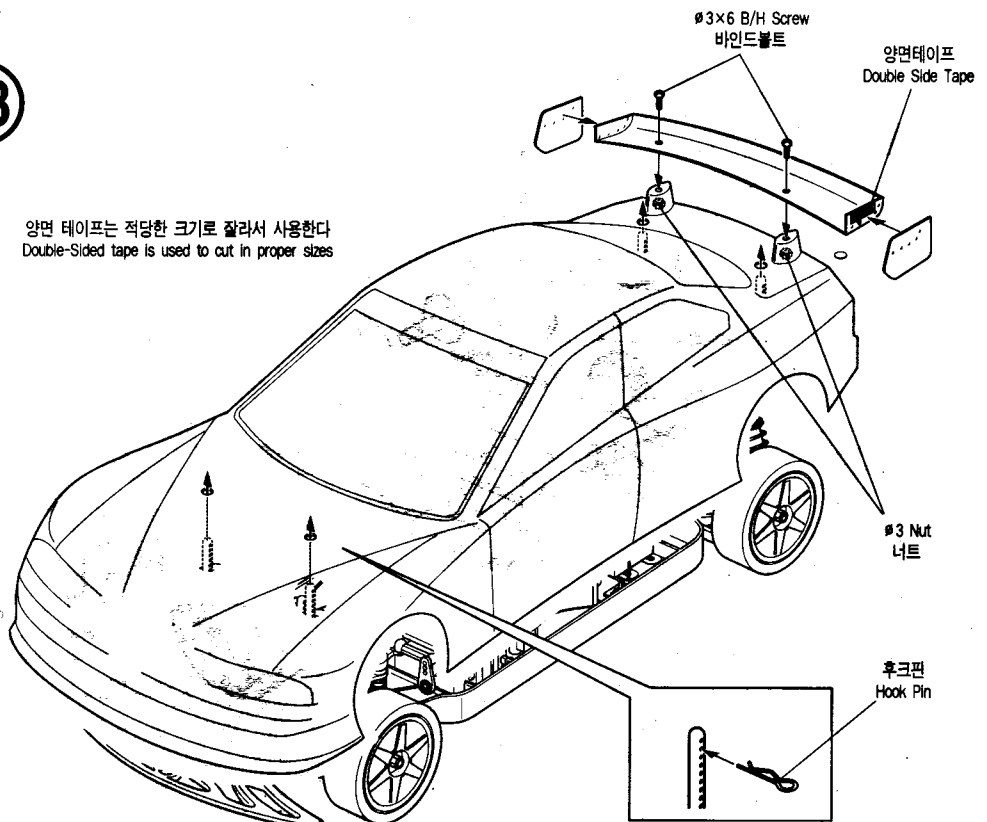

Ø3 Nut 너트

후크핀 Hook Pin

PACKING LIST

STR-A

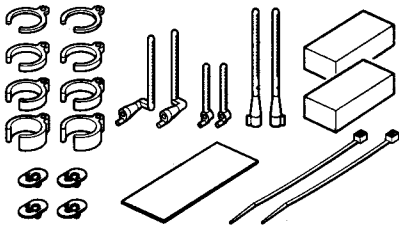

- Damper Guide 댐퍼 가이드 × 2조
- Body Mount 바디 마운트 × 3종
- Body Swivel 스위블 × 4
- Cable Tie 케이블 타이 × 2
- Battery spacer 배터리 스페이스 × 2
- Sponge Tape 양면 스폰지 테이프 × 1

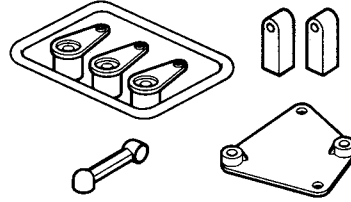

- Servo Horn Set 서보 혼 세트 × 1세트
- Servo Mount 서보 마운트 × 2
- Speed Controller Mount Adapter × 1
별첨기 마운트 어댑터
- Servo Link 서보 링크 × 1

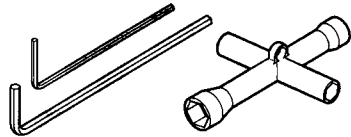

- Cross wrench 십자 렌치 × 1
- #1.5 L Wrench L 렌치 × 1

- #2 L Wrench L 렌치 × 1

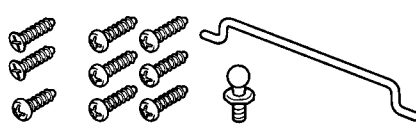

- #3×10 F/H Tapping screw 집시 비스 × 2
- #2.6×10 P/H Tapping screw 비스 × 1
- #3×8 P/H Tapping screw 비스 × 6
- #4.3 Pin ball 핀볼 × 1
- Speed control rod 변속기 로드 × 1

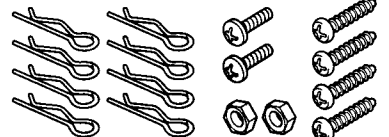

- Hook pin 후크 핀 × 8
- #3 Nut 너트 × 2

- #3×6 B/H screw 볼트 × 2
- #3×12 P/H Tapping screw 비스 × 4

STR-B

- Sticker (내수)스티커 × 1
- Masking 마스킹 × 1

- Antenna pipe 안테나 파이프 × 1

STR-D

- wheel 휠 × 4

- Inner foam 인너폼 × 4

STR-C

- Battery pad 배터리 패드 × 1

- STR4 Tire STR4 타이어 × 4

STR-E

- STR4 Instruction manual 설명서 × 1
- Body 바디 × 1

- STR4 Spare & Tuning parts diagram STR4 부품리스트 × 1

STR-4 RTI

PACKING LIST

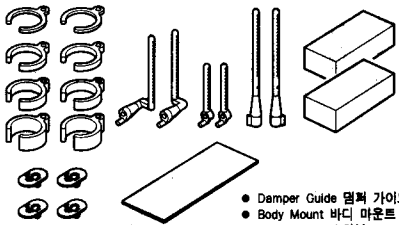

- Damper Guide 댐퍼 가이드 × 2조
- Body Mount 바디 마운트 × 3종
- Body Swivel 스위블 × 4
- Battery spacer 배터리 스페이스 × 2
- Sponge Tape 양면 스폰지 테이프 × 1

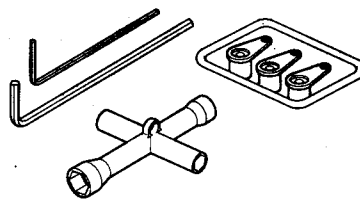

- Cross wrench 십자 렌치 × 1
- #1.5 L Wrench L 렌치 × 1

- #2 L Wrench L 렌치 × 1
- Servo Horn Set 서보 혼 세트 × 1세트

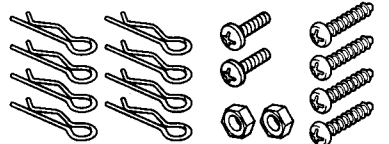

- Hook pin 후크 핀 × 8
- #3 Nut 너트 × 2

- #3×6 B/H screw 볼트 × 2
- #3×12 P/H Tapping screw 비스 × 4

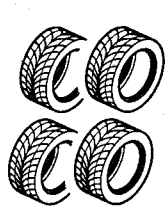

- STR4 Tire 타이어 × 4
- Antenna pipe 안테나파이프 × 1

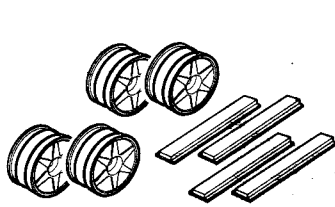

- Wheel 휠 × 4
- Inner foam 인너폼 × 4

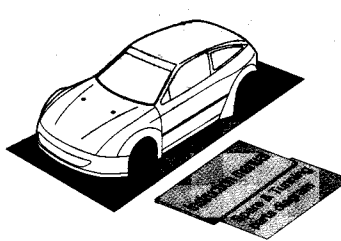

- Body 바디 × 1
- STR4 Instruction manual 설명서 × 1
- STR4 Spare & Tuning parts diagram 별지 설명서 × 1



- Battery pad 배터리패드 × 1
- Sticker 스티커 × 1

■ 부품이 파손되었거나 분실했을 경우

● 부품의 가격 및 판매에 관한 자세한 사항을 본사 서비스센터, 직매점, 총판점 및 가까운 과학교재사에 문의하시고 부품명과 부품번호를 확인하여 구입하시기 바랍니다.

■ 직매점 겸 A/S센터 수유동: 902-9293, 삼선교: 742-9293, 방배동: 552-9293, 양재동: 575-9997, 용산: 796-1214, 아셈하비센터: 6002-6293, 하반기나: 853-9293

■ A/S센터 본사: 908-7000(교환 147), 동대문: 745-9293, 천호동: 473-9293

■ 총판점 겸 A/S 센터 노원아카데미: 907-0940, 양천아카데미: 691-7108, 강북아카데미: 762-0980, 강남아카데미: 485-6884, 경기아카데미: (031)458-5591, 부산아카데미: (051)293-7449, 대구아카데미: (053)744-9293

■ 홈페이지 <http://www.academyhobby.com>

♣ 고객상담문의 080-969-7000

ACADEMY
HOBBY MODEL KITS

ACADEMY PLASTIC MODEL CO., LTD.
273-64, Suyu-dong, Kangbuk-gu, Seoul, Korea
TEL: 82-2-908-7000 FAX: 82-2-997-3003