

---

# ***O.S. ENGINE*** MAX-61SX/RX-HRING "WC" SERIES

---

## OWNER'S INSTRUCTION MANUAL

It is of vital importance, before attempting to operate your engine, to read the general **'SAFETY INSTRUCTIONS AND WARNINGS'** section on pages 2-5 of this booklet and to strictly adhere to the advice contained therein.

- Also, please study the entire contents of this instruction manual, so as to familiarize yourself with the controls and other features of the engine.
- Keep these instructions in a safe place so that you may readily refer to them whenever necessary.
- It is suggested that any instructions supplied with the model, radio control equipment, etc., are accessible for checking at the same time.

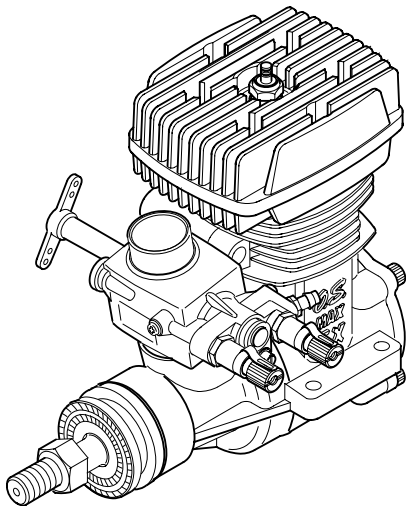

## CONTENTS

SAFETY INSTRUCTIONS AND WARNINGS ABOUT YOUR O.S. ENGINE -----	2~5	SUBSEQUENT READJUSTMENTS -----	19
INTRODUCTION -----	6	CARBURETTOR CLEANLINESS -----	19
BASIC ENGINE PARTS, INSTALLATION OF THE CARBURETOR -----	7	ADJUSTING CHART -----	20
INSTALLATION OF THE ENGINE -----	8	INSTALLATION OF THROTTLE SERVO CARE AND MAINTENANCE -----	21
BEFORE STARTING -----	9~10	ENGINE EXPLODED VIEW & PARTS LIST -----	22~29
FACTS ABOUT GLOW PLUGS -----	11	CARBURETOR EXPLODED VIEW & PARTS LIST -----	30~31
FUEL,CARBURETOR CONTROLS -----	12~13	THREE VIEW DRAWING -----	32~33
STARTING -----	13~15	O.S. GENUINE PARTS & ACCESSORIES -----	34
RUNNING-IN,ADJUSTMENT -----	15~18		

## **SAFETY INSTRUCTIONS AND WARNINGS ABOUT YOUR O.S. ENGINE**

Remember that your engine is not a "toy", but a highly efficient internal-combustion machine whose power is capable of harming you, or others, if it is misused.

As owner, you, alone, are responsible for the safe operation of your engine, so act with discretion and care at all times.

If at some future date, your O.S. engine is acquired by another person, we would respectfully request that these instructions are also passed on to its new owner.

- The advice which follows is grouped under two headings according to the degree of damage or danger which might arise through misuse or neglect.



### **WARNINGS**

These cover events which might involve serious (in extreme circumstances, even fatal) injury.



### **NOTES**

These cover the many other possibilities, generally less obvious sources of danger, but which, under certain circumstances, may also cause damage or injury.



## WARNINGS

- Never touch, or allow any object to come into contact with, the rotating parts.



- Model engine fuel is poisonous. Do not allow it to come into contact with the eyes or mouth. Always store it in a clearly marked container and out of the reach of children.



- Model engine fuel is also highly flammable. Keep it away from open flame, excessive heat, sources of sparks, or anything else which might ignite it. Do not smoke or allow anyone else to smoke, near to it.



- Never operate your engine in an enclosed space. Model engines, like automobile engines, exhaust deadly carbon-monoxide. Run your engine only in an open area.

- Model engines generate considerable heat. Do not touch any part of your engine until it has cooled. Contact with the muffler (silencer), cylinder head or exhaust header pipe, in particular, may result in a serious burn.





## NOTES

- These engine were designed for model helicopters. Do not attempt to use it for any other purpose.
- Mount the engine in your model securely, following the manufacturers' recommendations, using appropriate screws and locknuts.
- Install an effective silencer (muffler). Frequent close exposure to a noisy exhaust (especially in the case of the more powerful high-speed engines) may eventually impair your hearing and such noise is also likely to cause annoyance to others over a wide area.
- Check the linkage to the throttle arm before each flight.
- Avoid sudden high r.p.m. immediately after the engine is started, as the clutch will engage and you may be struck by the rotor.
- After starting the engine, carry out any needle-valve readjustments after stopping the rotor by closing the throttle to the lowest r.p.m.. Stop the engine before attempting to make other adjustments to the carburetor.
- Use an electric starter. The wearing of safety glasses is also strongly recommended. Press the rotor head down securely.
- Take care that the glow plug clip or battery leads do not come into contact with rotating parts.
- Adjust the throttle linkage so that the engine stops when the throttle stick and trim lever on the transmitter are fully retarded. Alternatively, the engine may be stopped by cutting off the fuel supply. Never try to stop the engine physically.



## NOTES

- Take care that loose clothing (ties, shirt sleeves, scarves etc.) do not come into contact with the rotor. Do not carry loose objects (such as pencils, screwdrivers, etc.) in a shirt pocket from where they could fall through the rotor disc.
- For their safety, keep all onlookers (especially small children) well back (at least 20 feet or 6 metres) when preparing your model for flight. If you have to carry the model to the take-off point with the engine running, be especially cautious. Hold the rotor securely and keep well clear of spectators.
- Warning! Immediately after a glowplug-ignition engine has been run and is still warm, conditions sometimes exist whereby it is just possible for the engine to restart when turned over WITHOUT the glowplug battery being reconnected. Remember this if you wish to avoid the risk of accidents.

---

## **INTRODUCTION**

The MAX-61SX-H RING "WC" is an up-rated version of the MAX-61SX-H RING helicopter engine. It is aimed at FAI World Championship(hence the suffix 'WC') Class F3C competition. Performance has been increased and the Type 60B carburetor has been modified for easier adjustment. High quality and high performance have been confirmed in exhaustive flight testing and in F3C contest results. The 61SX-H has a traditional sideexhaust layout, whereas the 61RX-H features a rear exhaust for users who prefer such a configuration. In all other respects, the two models are of identical design.

### **Note:**

Because of initial tightness, a standard electric starter may have difficulty in rotating the engine when cold, before it has been adequately run-in. In this case, use a high-torque type starter.

DO NOT, however, confuse tightness with the symptoms of hydraulic lock caused by an excess of fuel within the cylinder - often the result of over-priming.

Attempting to force the engine to turn over in this condition may cause internal damage. Instead, remove the glowplug, invert the engine and eject surplus fuel from the combustion-chamber.

## BASIC ENGINE PARTS

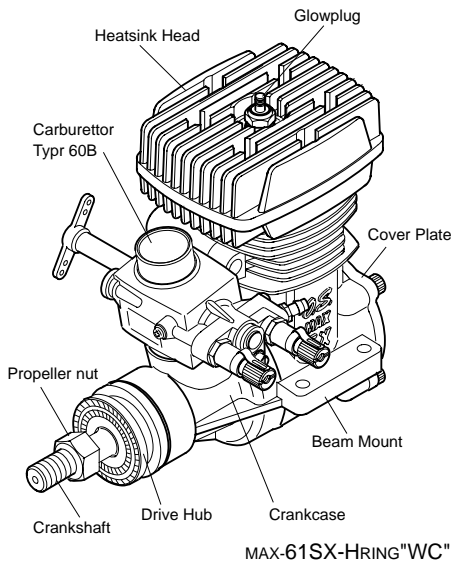

## INSTALLING THE GLOWPLUG

Install the washer on the glowplug and screw carefully into cylinder-head, making sure that it is not cross-threaded before tightening firmly.

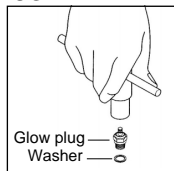

## INSTALLATION OF THE CARBURETOR

As delivered, the engine has its carburetor lightly fitted into its intake boss. Secure it as follows.

1. Loosen the retainer screw, rotate the carburetor to its correct position and press it well down into the intake boss, compressing the rubber gasket as shown in the sketch, before re-tightening screw.
2. Rotate the retainer screw gently until it stops, then tighten a further 120-180 degrees. Do not over-tighten the screw as this will damage the thermo-insulator.

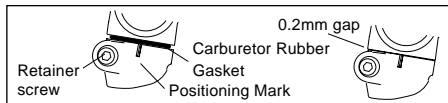



## INSTALLATION OF THE ENGINE

The under-surfaces of all O.S. engine beam mounting lugs are precision machined flat and exactly parallel to the engine's horizontal axis. It is essential that the engine mounts in the model are also accurately made and aligned. If they are not, they will cause stress and distortion within the engine itself, probably resulting in loss of performance and internal damage.

The recommended screws for securing the engine to the engine mounts in the model are 4mm or 6-32 NC steel Allen type. It is also advisable to use lock washers or LOCTITE to prevent nuts from loosening.

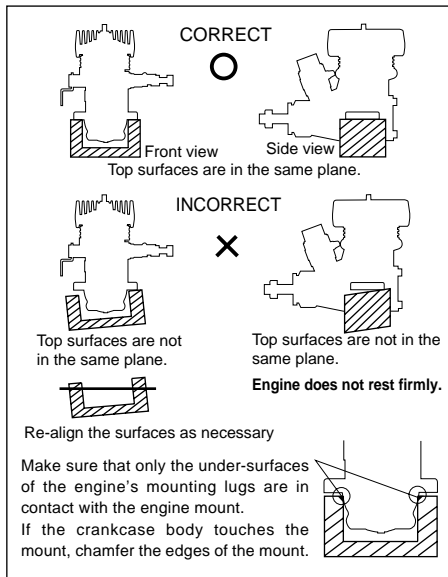

## BEFORE STARTING

### Tools, accessories, etc.

The following items are necessary for operating the engine.

### 1 Fuel

Model glowplug engine fuel of good quality, preferably containing a small percentage of nitromethane.

### 2 Glowplug

O.S. No.8 glowplug is installed in the engine.

### 3 Glowplug battery

The power source for heating the glowplug may be either a large heavy-duty 1.5volt dry cell, or preferably, a 2-volt rechargeable lead-acid cell .

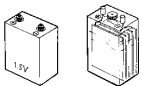

1.5 volt heavy-duty dry battery

or 2 volt rechargeable lead-acid cell (at least 5Ah)

If a 2-volt cell is employed, use a resistance wire, as shown, to reduce applied voltage, otherwise element will overheat and burn out.

### Warning (Very hot)

Never touch the nichrome wire while the battery is connected.

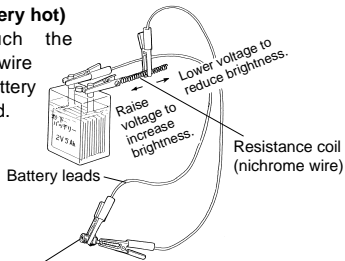

Adjust applied voltage by changing the position of clip on resistance coil until glowplug element is glowing bright red.

### 4 Plug wrench

Used for tightening glowplug. The O.S. long plug wrench is available as an optional accessory.

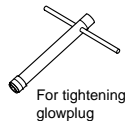

### 5 Battery leads

These are used to conduct current from the battery to the glowplug. Basically, two leads, with clips, are required, but, for greater convenience, twin leads with special glowplug connectors, as shown on the right, are commercially available.



## 6 Fuel bottle or pump

For filling the fuel tank, a simple, polyethylene "squeeze" bottle, with a suitable spout, is all that is required. Alternatively, one of the purpose-made manual or electric fuel pumps may be used to transfer fuel directly from your fuel container to the fuel tank.

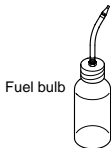

Fuel bulb

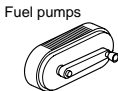

Fuel pumps

Manual

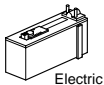

Electric

## 7 Fuel container filter

Install a filter on the outlet tube of your refuelling container to prevent entry of foreign matter into the fuel tank.

Fuel Can Filter



## 8 Silicone tubing

This is required for the connection between the fuel tank and engine.

Silicone tube

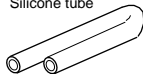

## 9 Hexagon starting shaft

This shaft mounted on an electric starting motor is driven into the main body of a helicopter to turn the engine.



## 10 Electric starter and starter battery

An electric starter is recommended for starting.

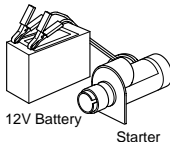

12V Battery

Starter

---

## FACTS ABOUT GLOWPLUGS

Since the compatibility of glowplug and fuel may have a marked effect on performance and reliability, it may be worthwhile to choose the R/C type plug found most suitable after tests. Recommended O.S. plugs are No.8 and A5. Carefully install plug finger-tight, before final tightening with the correct size plug wrench.

### The role of the glowplug

With a glowplug engine, ignition is initiated by the application of a 1.5-volt power source. When the battery is disconnected, the heat retained within the combustion chamber remains sufficient to keep the plug filament glowing, thereby continuing to keep the engine running. Ignition timing is 'automatic' : under reduced load, allowing higher rpm, the plug becomes hotter and, appropriately, fires the fuel/air charge earlier; conversely, at reduced rpm, the plug become cooler and ignition is retarded.

### Glowplug life

Particularly in the case of very high performance engines, glowplugs must be regarded as expendable items.

However, plug life can be extended and engine performance maintained by careful use, i.e.:

- Install a plug suitable for the engine.
- Use fuel containing a moderate percentage of nitromethane.
- Do not run the engine too lean and do not leave the battery connected while adjusting the needle.

### When to replace the glowplug

Apart from when actually burned out, a plug may need to be replaced because it no longer delivers its best performance, such as when:

- Filament surface has roughened and turned white.
- Filament coil has become distorted.
- Foreign matter has adhered to filament or plug body has corroded.
- Engine tends to cut out when idling.
- Starting qualities deteriorate.

---

## FUEL

Select, by practical tests, the most suitable fuel from among the best quality fuels available in your country for helicopter use. For the best throttle response, a fuel containing 10% to 30% nitromethane is preferable. Lubricants may be either castor-oil or a suitable synthetic oil (or a blend of both) provided that they are always of top quality. For consistent performance and long engine life, it is essential to use fuel containing AT LEAST 18% lubricant by volume. Some fuels containing coloring additives tend to deteriorate and may adversely affect running qualities. If in doubt compare to a fuel known to be good.

### Reminder!



**Model engine fuel is poisonous. Do not allow it to come into contact with the eyes or mouth. Always store it in a clearly marked container and out of the reach of children.**



**Model engine fuel is also highly flammable. Keep it away from open flame, excessive heat, sources of sparks, or anything else which might ignite it. Do not smoke, or allow anyone else to smoke, near to it.**

---

## CARBURETOR CONTROLS

With a fixed-wing model, power failure is rarely a serious threat to the safety of the aircraft since it can usually glide down to a safe landing. In a helicopter, on the other hand, it is vitally important that the engine keeps running and that there is a quick and reliable response to the throttle in order to ensure safe ascent and descent of the model.

**Three adjustable mixture controls are fitted to the Tyoe 60B. They are as follows.**

### A The High-Speed (Main) Needle Valve

When set to produce maximum power at full throttle, this establishes the basic fuel/air mixture strength. This is then maintained by the carburetor's automatic mixture control system to cover the engine's requirements at reduced throttle settings.

### B The Idle Mixture Control Screw

This provides the means of manually adjusting the 60B's mixture control valve. By setting the Mixture Control Screw for the best idling performance, the mixture control valve automatically ensures that fuel is accurately metered to maintain the correct mixture strength as the throttle is opened.

## C The Medium Speed Needle Valve

This is an extra control that can be brought into play, if necessary, after adjusting A and B above. It provides the means of fine-tuning mixture strength over that all-important part of a helicopter's throttle range where the model is flying in, or near, the hovering mode.

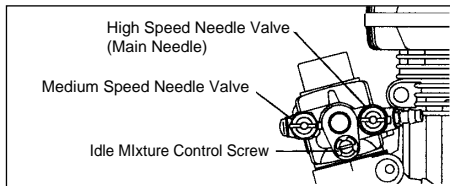

### HEX KEY NEEDLE ADJUSTMENT

The knurled heads of the two needle valves (High-Speed and Medium Speed) are provided with diagonal slots for use with a screwdriver. Alternatively, for more positive location via an Allen hexagonal key, these heads also have M2.6 internal threads, into which M2.6x5mm Allen cap-head screw may be fitted. To avoid risk of damage to the fuel passages when tightening these screws, remove the needle valves from the carburetor and use 'Loctite' thread-lock compound to secure the screw.

---

## STARTING

Be sure to use a muffler pressurized fuel feed. Use the same fuel as you intend to employ for actual operation of your model.

### 1. Opening and closing of the Needle-Valve

Turn the needle clockwise to close the needle-valve, and turn the needle counter-clockwise to open the needle-valve as shown in the sketch.

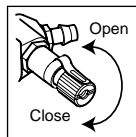

### 2. High Speed needle-valve:

exactly two turns open from the fully closed position. (**Note:** If a different muffler is used, this setting may require readjustment)

#### Idle Mixture Control Screw:

exactly two turns open from the fully closed position.

#### Medium Speed needle-valve:

exactly one turns open from the fully closed position.

### 3. Preparation of the starter

Install the starting shaft to the starter securely. Poor installation swings the starting shaft, which is dangerous.

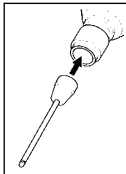

### 4. Checking the rotating direction of the starter

Make sure that the starter rotates to the direction shown in the sketch. If the direction is reverse, reverse the leads on battery.

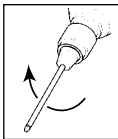

### 5. Inserting the starter shaft

Insert the starting shaft into the shaft cup securely.

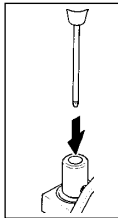

### 6. Priming

Without heating the glowplug, open the throttle a little from the idling position. Turn the engine using the starter until the fuel is seen to reach carburetor.

### 7. Preparation of starting

Make sure that the transmitter throttle stick is at the fully closed position and the throttle trim at center position, and make sure that idle-up switch on the transmitter is off. Hold the rotor head by hand so that rotor cannot rotate when the engine is Started. Also, steady the model with a foot on the landinggear skid.

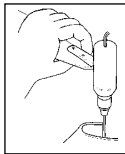

### 8. Starting

Connect the battery to the glowplug and start the engine by applying the starter. When started, switch off the starter and withdraw the starting shaft after making sure the rotation of the starter shaft stops.

### 9. Stopping the engine

Fully pull down the throttle trim on the transmitter.

### In case the engine does not stop.

Hold the rotor head, and pinch the silicone tube to stop the fuel supply. If it still does not stop, pull off the fuel tubing from the carburetor.

It is necessary to readjust the throttle linkage so that the carburetor rotor is fully closed when the throttle stick and throttle trim on the transmitter are fully pulled Down.

**NOTE:**

If the throttle response is poor or the engine stops due to a temporarily over-rich mixture immediately after the engine is started, pinch the fuel line for one or two seconds until the engine r.p.m. increase and the engine runs steadily.

**Reminder!**

Never touch, or allow any object to come into contact with, the rotating rotor.

---

## RUNNING-IN ("Breaking-in")

All internal-combustion engines benefit, to some degree, from extra care when they are run for the first few times — known as running-in or breaking-in.

This allows the working parts to mate together under load at operating temperature.

However, because O.S. engines are made with the aid of the finest modern precision machinery and from the best and most suitable materials, only a very

short and simple running-in procedure is required and can be carried out with the engine installed in the model. For the first few flights with a new engine — i.e. while the engine is being run-in — set the needle-valve for a slightly rich mixture — not excessively rich as this may result in poor throttle response and cause the engine to stop. About one half turn open from the normal setting will usually suffice.

---

## ADJUSTMENT

Please observe the following before beginning to make any adjustment.

- High-Speed Needle Valve. Turn this approximately 30° (3 to 4 click) at a time, when making initial adjustments; then in steps of approximately 15° (1 to 2 clicks) when making final adjustments.
- Medium-Speed Needle Valve. Turn approximately 45° (4 to 5 click) at a time.



- Idle Mixture Control Screw. A special technique is required here. If intending to make an adjustment (e.g. 90° in the same direction, before returning it to the new setting. If this procedure is not followed, movement of the throttle rotor may become stiff, resulting in undue loading of the throttle servo.

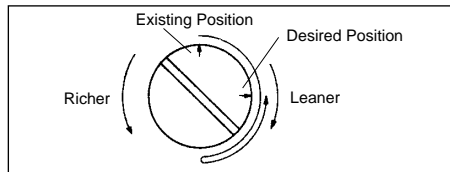

The general course of adjustments procedure is shown in the ADJUSTING CHART and is correct for a fuel containing 20% lubricant and 10-30% nitromethane.

Bear in mind that fuels containing relatively large percentages of power-boosting nitromethane operate at richer mixture settings than are needed for mild fuels and will, therefore, require the High-Speed Needle Valve to be readjusted accordingly. The type and percentage of lubricant used is also a factor here, as noted later in these instructions.

**This carburetor is not fitted with a throttle stop screw. Instead, idling speed is adjusted by means of the throttle trim lever on the transmitter.**

## ADJUSTMENT PROCEDURE

As a safety measure, first check the transmitter controls, including the throttle stick and trim lever positions, and hold the main rotor securely before starting the engine.

1. Warm the engine by allowing it to idle for about 30 seconds. If the engine stops, advance the throttle trim lever slightly to increase the idling rpm. Then open the throttle sufficiently to 'float' the model above the ground.

If, at this time, the engine is slow to pick up and produces an excess of exhaust smoke, the mixture is too rich. Correct this condition by turning the Mixture Control Screw clockwise. If the mixture is extremely rich, engine rpm will become unstable: opening the throttle will produce a great deal of smoke and rpm may drop suddenly or the engine may stop. This condition may also be initiated by an excessively prolonged warming-up period.

If, on the other hand, the mixture is too lean, this will be indicated by a marked lack of exhaust smoke and a tendency for the engine to cut out when the throttle is opened. In this case, turn the Mixture Control Screw counter-clockwise to enrich the mixture.

2. Having provisionally set the idle mixture, the next step is to adjust the mixture for hovering flight.

Hover the model and actuate the throttle to observe response over the medium speed range. If the engine smokes excessively and throttle response is poor, the mixture is too rich ; in which case, land the model and turn the High-Speed Needle Valve clockwise. Do not close the High-Speed Needle Valve more than the recommended initial adjustment (3 to 4 clicks) at a time, keeping it a little on the rich side at this stage. DO NOT touch the Medium Speed Needle Valve.

If, on the other hand, hovering is not stable and response to the throttle is over-sensitive, or if the engine tends to overheat, this indicates that the mixture is too lean and should be corrected by turning the High-Speed Needle Valve counter-clockwise.

When satisfactory hovering flight has been achieved, land the model again and re-check the engine's idling qualities.

After about 10 seconds of idling, open the throttle to 'float' the model. If the transition is smooth, the idle mixture is O.K. If the symptoms of either rich or lean running are observed, readjust the Idle Mixture Control Screw accordingly.

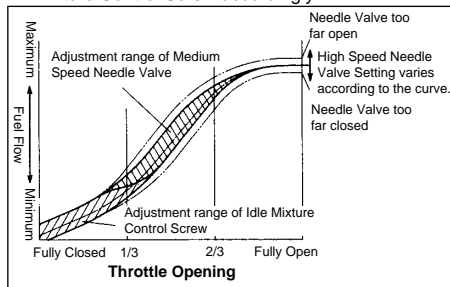

**NOTE:** With this carburetor, neither the Idle Mixture Control Screw adjustment, nor the Medium Speed Needle Valve adjustment has any effect on mixture strength when the throttle is fully (or almost fully) open.

3. Now adjust the High-Speed Needle Valve to achieve the best performance when the model is flying at full throttle. If, at full throttle, acceleration is poor, the exhaust unduly smoky and the model fails to reach expected straight line speed, the mixture is too rich and the High-Speed Needle Valve setting will need to be reduced.

If, however, after smoothly accelerating to satisfactory high-speed straight and level flight, power is lost when the model is pulled up into a climb, the mixture is too lean. In this case, land the model immediately and readjust the High-Speed Needle Valve to a richer setting.

4. Having now found the optimum setting for the High-Speed Needle Valve, re-check the engine's idling performance, finetuning the Idle Mixture Control Screw, if necessary, to perfect the idle.
5. Now re-check hovering performance. It may be found that (with the High-Speed Needle Valve now set for optimum full-throttle performance) hovering will reveal symptoms of slightly lean running at medium speeds. DO NOT touch the High-Speed Needle Valve.

It is at this point that the Medium Speed Needle Valve, previously kept one turn open, may be brought into operation. Open the Medium Speed Needle Valve 45°, or 4-5 clicks, then fine tune until the optimum hovering performance is obtained. If on the other hand, hovering reveals rich running, close the Medium Speed Needle Valve gradually until the optimum hovering performance is obtained.

**NOTE:** It is NOT necessary to open the Medium Speed Needle Valve if symptoms of lean running at hovering speeds remain unconfirmed.

---

## SUBSEQUENT READJUSTMENTS

Once the engine has been run-in and the carburetor controls properly set up, it should be unnecessary to alter the mixture settings, except to make minor changes to the Main (High-Speed) Needle Valve occasionally, to take account of differences in climatic conditions.

However, as previously mentioned, the use of a different fuel, particularly one containing more, or less, nitromethane and / or a different type or proportion of lubricating oil, is likely to call for some modification to the High-Speed Needle-Valve adjustment.

As a safety measure, it is advisable to increase the High-Speed Needle Valve setting by an extra half-turn counter-clockwise, prior to establishing the new setting. The same applies if the silencer type is changed. A different silencer may alter the exhaust pressure applied to the fuel feed and call for a revised Needle-Valve setting.

The use of a different glowplug, or changes to the main rotor and its pitch angles may also require compensating carburetor readjustments.

---

## CARBURETOR CLEANLINESS

The correct functioning of the carburetor depends on its small fuel orifices remaining clear.

The minute particles of foreign matter that are present in any fuel can easily partially obstruct these orifices and upset mixture strength so that engine performance becomes erratic and unreliable.

It is recommended that fuel is passed through a filter when the tank is filled and that a good in-line filter is installed between the fuel tank and carburetor and, furthermore, that this filter is frequently cleaned to remove dirt and lint that accumulates on the filter screen.

Finally, occasionally remove the needle-valve holder from the carburetor as shown in Photo and extract any remaining foreign matter that may have lodged in the location shown in Photo, right.

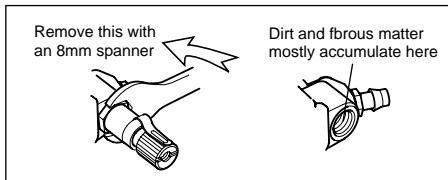

# ADJUSTING CHART

High Speed Needle Valve - 2 turns opened from fully closed position.  
Medium Speed Needle Valve - 1 turns opened from fully closed position.  
Idle Mixture Control Screw - 2 turns opened from fully closed position.

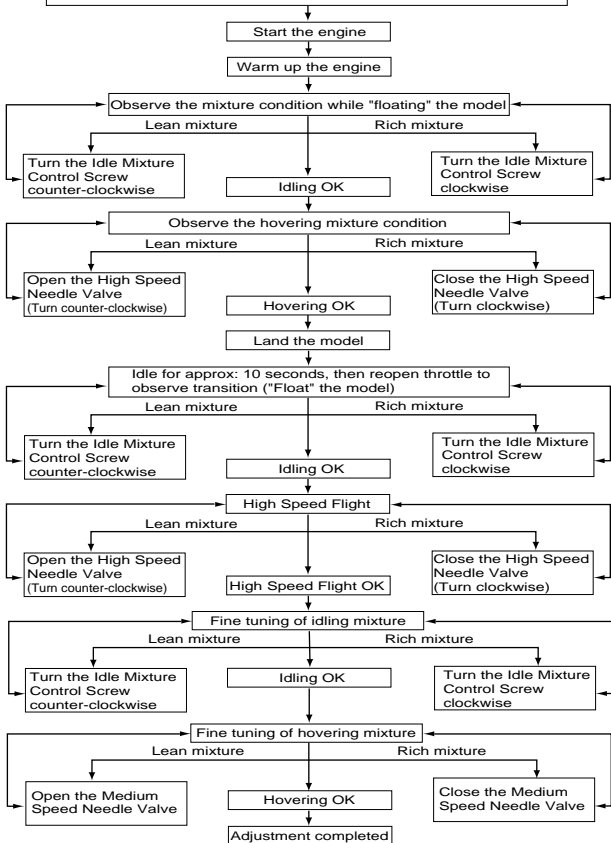

---

## INSTALLATION OF THROTTLE SERVO

After the engine in the helicopter, please observe the following recommendations when linking the throttle servo to the carburetor.

Locate the servo so that its output arm and the throttle pushrod are, as closely as possible, directly in line with carburetor's throttle arm, as shown.

Throttle control rod A and B should be equal of length. Set the linkage so that the servo output arm and throttle arm become parallel when the throttle stick on the transmitter is at middle position. If differential throttle movement is required, make necessary adjustment at the transmitter.

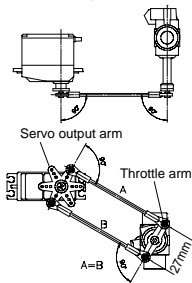

---

## CARE AND MAINTENANCE

1. The minute particles of foreign matter, that are present in any fuel may, by accumulating and partially obstructing fuel flow, cause engine performance to become erratic and unreliable. O.S. 'Super-Filters' (large and small) are available, as optional extras, to deal with this problem. One of these filters, fitted to the outlet tube inside

your refueling container, will prevent the entry of foreign material into the fuel tank. It is also recommended that a good in-line filter be installed between the tank and carburetor.

2. Do not forget to clean the filters regularly to remove dirt and lint that accumulate on the filter screens. Also, clean the carburetor itself occasionally.
3. At the end of each operating session, drain out any fuel that may remain in the fuel tank. Next, energize the glowplug and try to restart the engine to burn off any fuel that may remain inside the engine. Repeat this procedure until the engine fails to fire. Remove the glowplug and eject any remaining fuel/oil residue by rotating the engine with an electric starter for 4 to 5 seconds while the engine is still warm.
4. Finally, inject some after-run oil into the engine. Rotate the engine a few times by hand, to make sure that it is free, and then with an electric starter for 4 to 5 seconds to distribute the oil to all the working parts.

### Note:

**Do not inject after-run oil into the carburetor as this may cause the O-rings inside the carburetor to deteriorate.**

These procedures will reduce the risk of starting difficulties and of internal corrosion after a period of storage.

# MAX-61SX-HRING "WC" EXPLODED VIEW

—22—

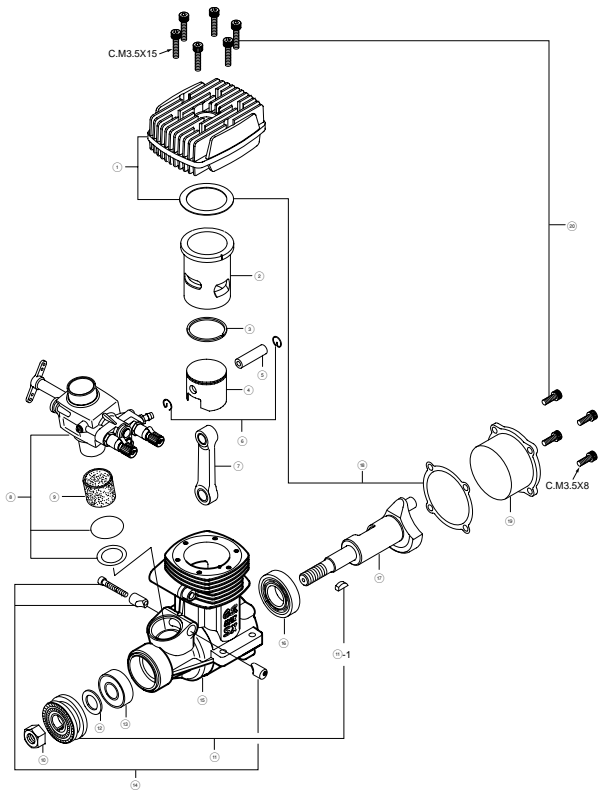

\* Type of screw

C...Cap Screw M...Oval Fillister-Head Screw

F...Flat Head Screw N...Round Head Screw S...Set Screw

---

## MAX-61SX-HRING"WC" ENGINE PARTS LIST

No.	Code No.	Description
①	27904200	Heatsink Head
②	27953100	Cylinder Liner
③	26703404	Piston Ring
④	27903200	Piston
⑤	26606008	Piston Pin
⑥	27917000	Piston Pin Retainer
⑦	27905000	Connecting Rod
⑧	27981010	Carburetor Complete 60B
⑨	27984900	60B Thermo insulator
⑩	45010002	Propeller Nut
⑪	27708010	Drive Hub
⑪-1	27708200	Woodruff Key
⑫	46120000	Thrust Washer
⑬	26731002	Crankshaft Ball Bearing(Front)
⑭	27981710	Carburetor Retainer Assembly
⑮	27951000	Crankcase
⑯	27930000	Crankshaft Ball Bearing(Rear)
⑰	27952000	Crankshaft
⑱	27914000	Gasket Set
⑲	27907000	Cover Plate
⑳	27913000	Screw Set
	71608001	Glow Plug No.8

The specifications are subject to alteration for improvement without notice.



# MAX-61SX-HG/HGLRING"WC" EXPLODED VIEW

—24—

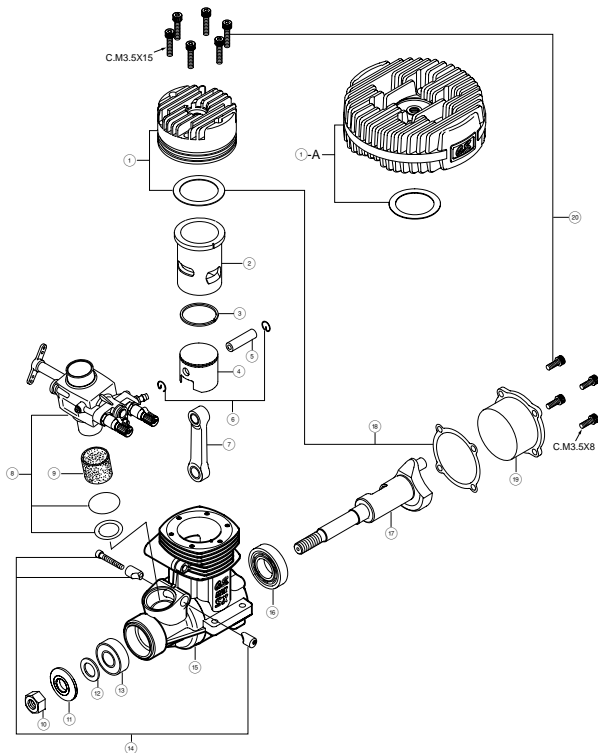

\* Type of screw

C...Cap Screw M...Oval Fillister-Head Screw

F...Flat Head Screw N...Round Head Screw S...Set Screw

---

## MAX-61SX-HG/HGLRING"WC" ENGINE PARTS LIST

No.	Code No.	Description
①	27904300	Cylinder Head (For 61SX-HG)
①-A	27904210	Heatsink Head (For 61SX-HGL)
②	27953100	Cylinder Liner
③	26703404	Piston Ring
④	27903200	Piston
⑤	26606008	Piston Pin
⑥	27917000	Piston Pin Retainer
⑦	27905000	Connecting Rod
⑧	27981010	Carburetor Complete 60B
⑨	27984900	60B Thermo insulator
⑩	23210007	Propeller Nut
⑪	23009006	Propeller Washer
⑫	27720000	Thrust Washer
⑬	26731002	Crankshaft Ball Bearing(Front)
⑭	27981710	Carburetor Retainer Assembly
⑮	27951000	Crankcase
⑯	27930000	Crankshaft Ball Bearing(Rear)
⑰	27952010	Crankshaft
⑱	27914000	Gasket Set
⑲	27907000	Cover Plate
⑳	27913000	Screw Set
	71608001	Glow Plug No.8

The specifications are subject to alteration for improvement without notice.

# MAX-61RX-HRING"WC" EXPLODED VIEW

—26—

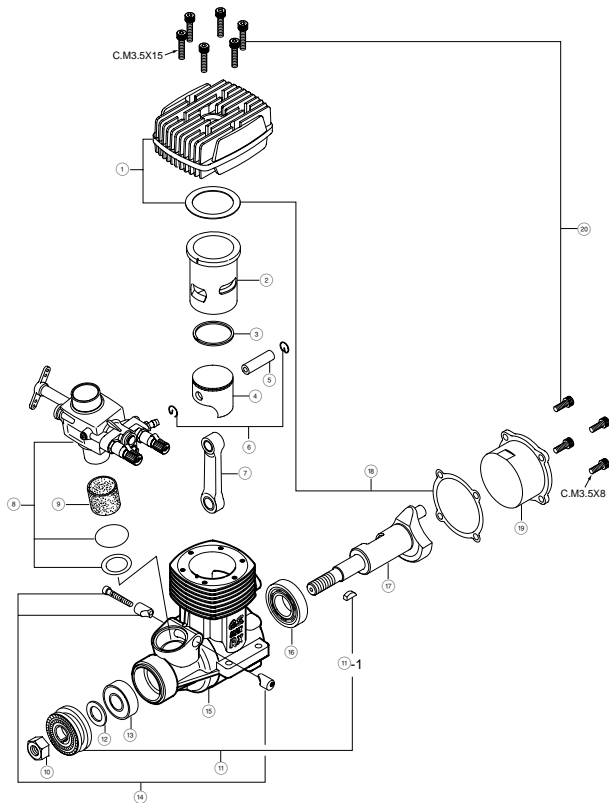

\* Type of screw

C···Cap Screw M···Oval Fillister-Head Screw

F···Flat Head Screw N···Round Head Screw S···Set Screw

---

## MAX-61RX-HRING"WC" ENGINE PARTS LIST

No.	Code No.	Description
①	27904200	Heatsink Head
②	27953100	Cylinder Liner
③	26703404	Piston Ring
④	27923200	Piston
⑤	27106007	Piston Pin
⑥	27917000	Piston Pin Retainer
⑦	27905000	Connecting Rod
⑧	27981010	Carburetor Complete 60B
⑨	27984900	60B Thermo insulator
⑩	45010002	Propeller Nut
⑪	27708010	Drive Hub
⑪-1	27708200	Woodruff Key
⑫	46120000	Thrust Washer
⑬	26731002	Crankshaft Ball Bearing(Front)
⑭	27981710	Carburetor Retainer Assembly
⑮	27941000	Crankcase
⑯	27930000	Crankshaft Ball Bearing(Rear)
⑰	27952000	Crankshaft
⑱	27914000	Gasket Set
⑲	27927000	Cover Plate
⑳	27913000	Screw Set
	71608001	Glow Plug No.8

The specifications are subject to alteration for improvement without notice.

# MAX-61RX-HG/HGLRING"WC" EXPLODED VIEW

—28—

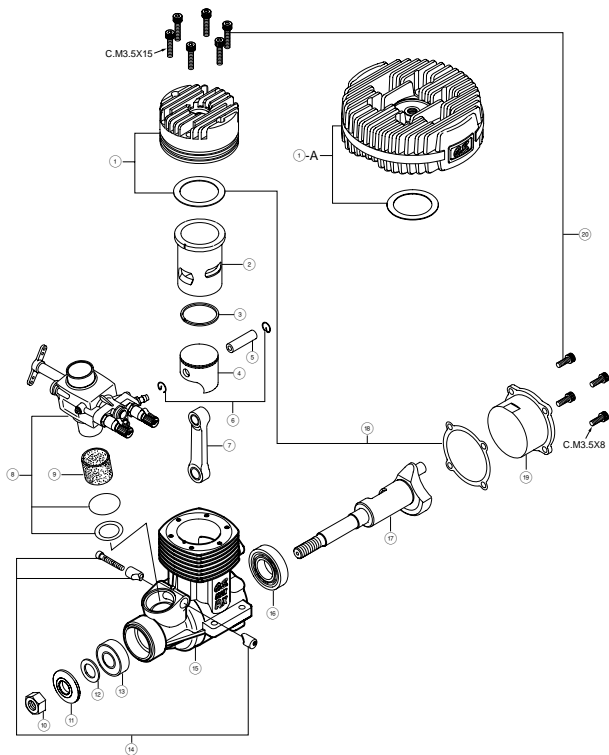

\* Type of screw

C···Cap Screw M···Oval Fillister-Head Screw

F···Flat Head Screw N···Round Head Screw S···Set Screw

---

## MAX-61RX-HG/HGLRING"WC" ENGINE PARTS LIST

No.	Code No.	Description
①	27904300	Heatsink Head (For 61SX-HG)
①-A	27904210	Heatsink Head (For 61SX-HGL)
②	27953100	Cylinder Liner
③	26703404	Piston Ring
④	27923200	Piston
⑤	27106007	Piston Pin
⑥	27917000	Piston Pin Retainer
⑦	27905000	Connecting Rod
⑧	27981010	Carburetor Complete 60B
⑨	27984900	60B Thermo insulator
⑩	23210007	Propeller Nut
⑪	23009006	Propeller Washer
⑫	27720000	Thrust Washer
⑬	26731002	Crankshaft Ball Bearing(Front)
⑭	27981710	Carburetor Retainer Assembly
⑮	27941000	Crankcase
⑯	27930000	Crankshaft Ball Bearing(Rear)
⑰	27952010	Crankshaft
⑱	27914000	Gasket Set
⑲	27927000	Cover Plate
⑳	27913000	Screw Set
	71608001	Glow Plug No.8

The specifications are subject to alteration for improvement without notice.

## 60B CARBURETOR EXPLODED VIEW

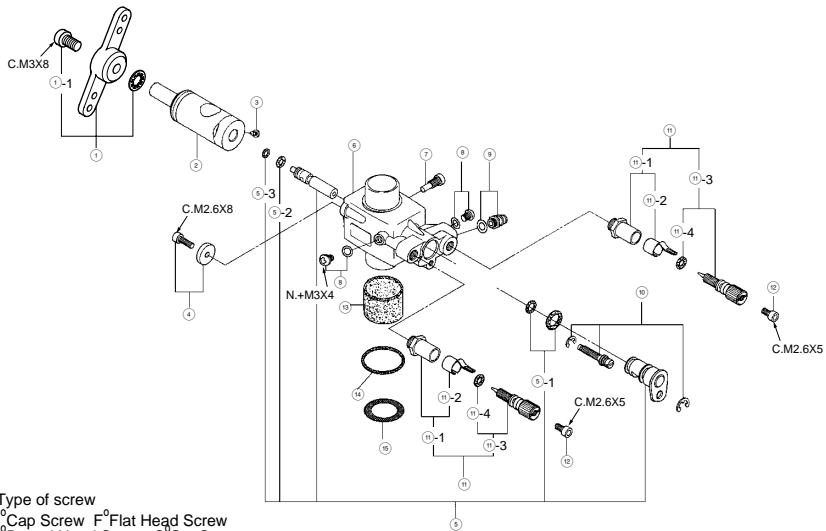

] Type of screw

C° Cap Screw F° Flat Head Screw

N° Round Head Screw S° Set Screw

## 60B CARBURETOR PARTS LIST

No.	Code No.	Description
①	2 7381 410	Throttle Lever
①-1	2 2826 131	Throttle Lever Retaining Screw
②	2 7981 200	Carburettor Rotor
③	2 7981 920	Metering Nozzle Retaining Screw
④	2 7981 220	Rotor Guide Washer
⑤	2 7981 301	Mixture Control Valve Assembly
⑤-1	2 7981 850	"O"Ring Set
⑤-2	2 7881 820	"O"Ring (L)
⑤-3	2 2781 800	"O"Ring (S)
⑥	2 7981 110	Carburettor Body
⑦	2 7981 600	Fixed Throttle Stop Screw

No.	Code No.	Description
⑧	2 7881 120	Plug Screw
⑨	2 2681 953	Fuel Inlet
⑩	2 7981 332	Mixture Control Screw
⑪	2 7981 900	Needle Valve Assembly
⑪-1	2 7381 940	Needle Valve Holder Assembly
⑪-2	2 6711 305	Ratchet Spring
⑪-3	2 7981 910	Needle
⑪-4	2 4981 837	"O"Ring (2pcs.)
⑫	4 1621 000	Screw for Needle (4pcs.)
⑬	2 7984 900	60B Thermo insulator
⑭	2 7915 000	Carburettor Rubber Gasket
⑮	2 7915 100	Carburettor Sealing Washer (1pc.)

Specifications are subject to alteration for improvement without notice.



## 61SX-HRING"WC" THREE VIEW DRAWING

### SPECIFICATIONS

■ Displacement	9.95 cc (0.607 cu.in.)
■ Bore	24.0mm (0.945 in.)
■ Stroke	22.0mm (0.866 in.)
■ Practical R.P.M.	2,000~18,000 r.p.m.
■ Power output	2.2 bhp / 16,000 r.p.m.
■ Weight	600g(21.2oz.) SX-H

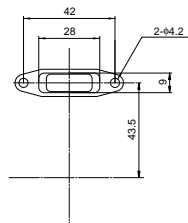
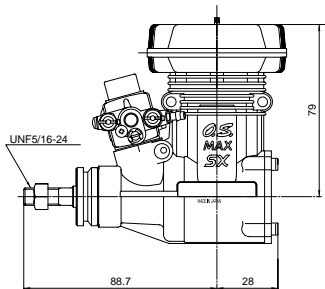
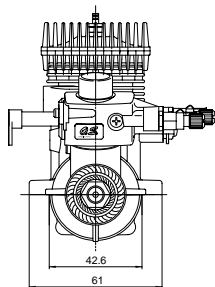
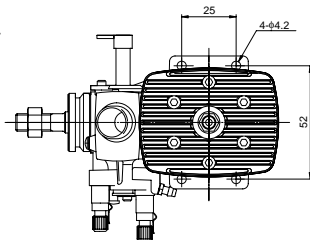

Dimensions(mm)

## 61RX-HRING"WC" THREE VIEW DRAWING

### SPECIFICATIONS

■ Displacement	9.95 cc (0.607 cu.in.)
■ Bore	24.0mm (0.945 in.)
■ Stroke	22.0mm (0.866 in.)
■ Practical R.P.M.	2,000~18,000 r.p.m.
■ Power output	2.2 bhp / 16,000 r.p.m.
■ Weight	597g(21.1oz.) RX-H

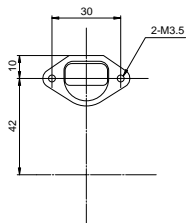
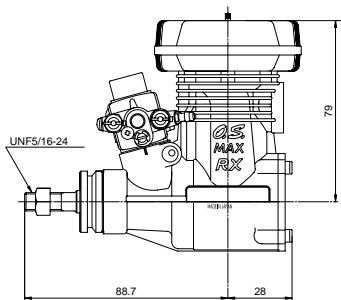
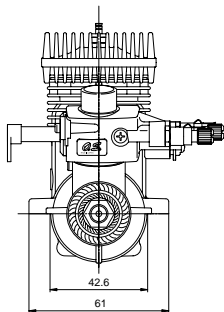
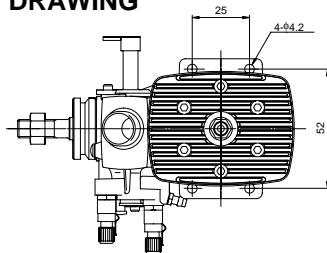

Dimensions(mm)

---

## O.S. GENUINE PARTS & ACCESSORIES

---

### ■ O.S. GLOW PLUGS

No.8 (71608001)    A5 (71605100)



### ■ MIXTURE CONTROL CARBURETOR 60D (27983000)

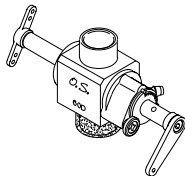

### ■ IN-FLIGHT CONTROL NEEDLE VALVE (71705000)



### ■ SUPER FILTER (72403050)



### ■ CRANKSHAFT CLAMP (71530300)

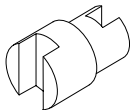

### ■ LOCK WASHER(10set) M3 (55500002)

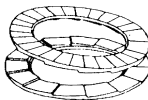

### ■ LONG SOCKET WRENCH WITH PLUG GRIP (71521000)

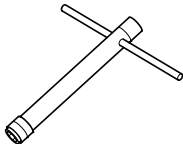



***O.S. ENGINES MFG.CO.,LTD.***

6-15 3-Chome Imagawa Higashisumiyoshi-ku  
Osaka 546-0003, Japan TEL. (06) 6702-0225

FAX. (06) 6704-2722

URL : <http://www.os-engines.co.jp>