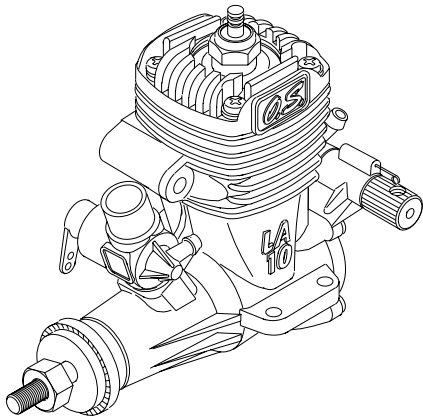

O.S. ENGINE

MAX-10,15,25 'LA SERIES' ENGINES

OWNER'S INSTRUCTION MANUAL

It is of vital importance, before attempting to operate your engine, to read the general **'SAFETY INSTRUCTIONS AND WARNINGS'** section on pages 2-6 of this booklet and to strictly adhere to the advice contained therein.

- Also, please study the entire contents of this instruction manual, so as to familiarize yourself with the controls and other features of the engine.
- Keep these instructions in a safe place so that you may readily refer to them whenever necessary.
- It is suggested that any instructions supplied with the aircraft, radio control equipment, etc., are accessible for checking at the same time.



CONTENTS

SAFETY INSTRUCTIONS AND WARNINGS ABOUT YOUR O.S. ENGINE -----	2~6	TROUBLE SHOOTING WHEN THE ENGINE FAILS TO START -----	26~27
INTRODUCTION -----	7	CARE AND MAINTENANCE -----	28
INSTALLATION OF THE ENGINE -----	8	OPTIONAL PARTS & ACCESSORIES -----	29
INSTALLATION OF SILENCER -----	9	10LA ENGINE EXPLODED VIEW & PARTS LIST -----	30~31
BEFORE STARTING -----	10~12	15/25LA ENGINE EXPLODED VIEW & PARTS LIST -----	32~33
ADVICE ON SELECTION OF FUEL, GLOW PLUG & PROPELLER -----	12~14	CARBURETTOR EXPLODED VIEW & PARTS LIST -----	34
STARTING THE ENGINE -----	14~22	10LA THREE VIEW DRAWING -----	35
RUNNING-IN (Breaking-in) -----	23	15/25LA THREE VIEW DRAWING -----	36
CARBURETTOR -----	23~24		
15/25LA CARBURETTOR AIR-BLEED ADJUSTMENT -----	25		

SAFETY INSTRUCTIONS AND WARNINGS ABOUT YOUR O.S. ENGINE

Remember that your engine is not a "toy", but a highly efficient internal-combustion machine whose power is capable of harming you, or others, if it is misused.

As owner, you, alone, are responsible for the safe operation of your engine, so act with discretion and care at all times.

If at some future date, your O.S. engine is acquired by another person, we would respectfully request that these instructions are also passed on to its new owner.

- The advice which follows is grouped under two headings according to the degree of damage or danger which might arise through misuse or neglect.



WARNINGS

These cover events which might involve serious (in extreme circumstances, even fatal) injury.



NOTES

These cover the many other possibilities, generally less obvious sources of danger, but which, under certain circumstances, may also cause damage or injury.



WARNINGS

- Never touch, or allow any object to come into contact with, the rotating propeller and do not crouch over the engine when it is running.



- A weakened or loose propeller may disintegrate or be thrown off and, since propeller tip speeds with powerful engines may exceed 600 feet(180 metres) per second, it will be understood that such a failure could result in serious injury, (see 'NOTES' section relating to propeller safety).

- Model engine fuel is poisonous. Do not allow it to come into contact with the eyes or mouth. Always store it in a clearly marked container and out of the reach of children.



- Model engine fuel is also highly flammable. Keep it away from open flame, excessive heat, sources of sparks, or anything else which might ignite it. Do not smoke or allow anyone else to smoke, near to it.



- Never operate your engine in an enclosed space. Model engines, like automobile engines, exhaust deadly carbon-monoxide. Run your engine only in an open area.

- Model engines generate considerable heat. Do not touch any part of your engine until it has cooled. Contact with the muffler (silencer), cylinder head or exhaust header pipe, in particular, may result in a serious burn.





NOTES

- This engine was designed for model aircraft. Do not attempt to use it for any other purpose.
- Mount the engine in your model securely, following the manufacturers' recommendations, using appropriate screws and lock-nuts.
- Be sure to use the silencer (muffler) supplied with the engine. Frequent exposure to an open exhaust may eventually impair your hearing. Such noise is also likely to cause annoyance to others over a wide area.
- If you remove the glowplug from the engine and check its condition by connecting the battery leads to it, do not hold the plug with bare fingers. Use an appropriate tool or a folded piece of cloth.
- Fit a top-quality propeller of the diameter and pitch specified for the engine and aircraft. Locate the propeller on the shaft so that the curved face of the blades faces forward-i.e. in the direction of flight. Firmly tighten the propeller nut, using the correct size wrench.



NOTES

- Always check the tightness of the propeller nut and retighten it, if necessary, before restarting the engine, particularly in the case of four-stroke-cycle engines. If a safety locknut assembly is provided with your engine, always use it. This will prevent the propeller from flying off in the event of a "backfire", even if it loosens.
- If you install a spinner, make sure that it is a precision made product and that the slots for the propeller blades do not cut into the blade roots and weaken them.
- Preferably, use an electric starter. The wearing of safety glasses is also strongly recommended.
- Discard any propeller which has become split, cracked, nicked or otherwise rendered unsafe. Never attempt to repair such a propeller: destroy it. Do not modify a propeller in any way, unless you are highly experienced in tuning propellers for specialized competition work such as pylon-racing.
- Take care that the glow plug clip or battery leads do not come into contact with the propeller. Also check the linkage to the throttle arm. A disconnected linkage could also foul the propeller.
- After starting the engine, carry out any needle-valve readjustments from a safe position behind the rotating propeller. Stop the engine before attempting to make other adjustments to the carburettor.



NOTES

- Adjust the throttle linkage so that the engine stops when the throttle stick and trim lever on the transmitter are fully retarded. Alternatively, the engine may be stopped by cutting off the fuel supply. Never try to stop the engine physically.
- Take care that loose clothing (ties, shirt sleeves, scarves, etc.) do not come into contact with the propeller. Do not carry loose objects (such as pencils, screwdrivers, etc.) in a shirt pocket from where they could fall through the propeller arc.
- Do not start your engine in an area containing loose gravel or sand. The propeller may throw such material in your face and eyes and cause injury.
- For their safety, keep all onlookers (especially small children) well back (at least 20 feet or 6 meters) when preparing your model for flight. If you have to carry the model to the take-off point with the engine running, be especially cautious. Keep the propeller pointed away from you and walk well clear of spectators.
- Warning! Immediately after a glowplug-ignition engine has been run and is still warm, conditions sometimes exist whereby it is just possible for the engine to abruptly restart if the propeller is casually flipped over compression WITHOUT the glowplug battery being reconnected. Remember this if you wish to avoid the risk of a painfully rapped knuckle!

INTRODUCTION

THE MAX-10LA,15LA,25LA have been developed to meet the requirements of beginners and sport flyers.

Of modern design and having a separate needle-valve unit mounted at the rear, where manual adjustment is safely remote from the rotating propeller, they offer the advantages of reliability and easy handling, at lower cost. Like all O.S. engines they are built to standards of engineering excellence that have evolved through more than 60 years' experience in the design and production of model internal-combustion engines. Advanced modern precision machinery, top quality materials and the efforts of highly skilled craftsmen and technicians are combined to ensure a continuation of the levels of performance, durability and reliability for which O.S. is world famous.

The 'midnight blue' external finish may be decolorized by very high surface temperature or by certain solvents. Such decolorization does not affect engine performance, however.

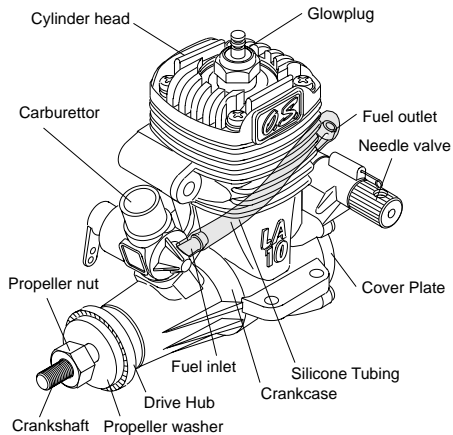

Connect the short length of fuel tubing supplied securely between the fuel outlet and the fuel inlet. In the event of the tubing becoming damaged, it should be replaced with a suitable length of best quality 5mm ODX2mm ID silicone tubing. Use similar material to connect the fuel inlet nipple to the fuel tank.

INSTALLATION

Installation in the model

A typical method of beam mounting is shown below, left.

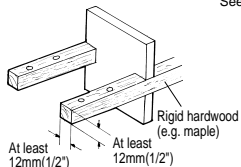

O.S. radial motor mount
(Available as an optional extra part.
See parts list)

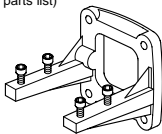

Make sure that the mounting beams are parallel and that their top surfaces are in the same plane.

CORRECT

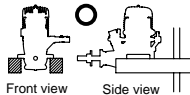

Top surfaces are in the same plane.

INCORRECT

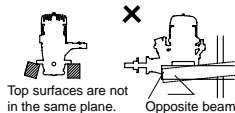

Top surfaces are not in the same plane.

Re-align the surfaces as necessary

Top surfaces are not in the same plane.

Engine does not rest firmly.

How to fasten the mounting screws.

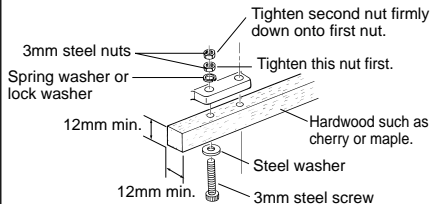

Hardwood mounting beams

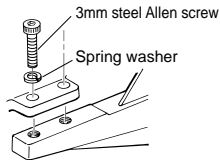

**O.S. radial motor mount
(cast aluminum)**

NEEDLE-VALVE EXTENSION

The needle-valve supplied with these engines is designed to incorporate an extension so that, when the engine is enclosed within the fuselage, the needle-valve may be adjusted from the outside.

Cut a commercially available rod to the required length, bend one end to an L shape, insert it into needle's center hole and secure it by tightening the set-screw in the needle-valve knob with 1.5mm. Allen key.

INSTALLATION OF SILENCER

The angled exhaust of the silencer can be rotated to any desired position in the following manner:

- 1) Loosen the locknut and assembly screw.
- 2) Set the exhaust outlet at the required position by rotating the rear part of the silencer.
- 3) Re-tighten the assembly screw, followed by the locknut. The standard silencer is quite effective but reduces power to some degree.

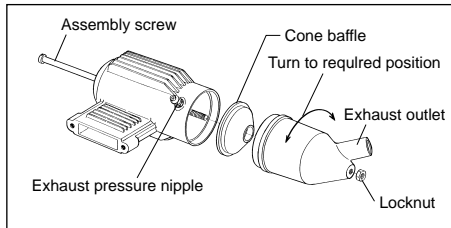

Reminder!



Model engines generate considerable heat. Do not touch any part of your engine until it has cooled. Contact with the muffler (silencer), cylinder head or exhaust header pipe, in particular, may result in a serious burn.

BEFORE STARTING

Tools, accessories, etc.

The following items are necessary for operating the engine.

1 Fuel

Model glowplug engine fuel of good quality, preferably containing a small percentage of nitromethane. (See "Advice on selection of fuel, glowplug and propeller")

2 Glowplug

O.S. A3 glowplug is installed in the engine.

3 Propeller

Suggested size is 7x4(10LA), 8X4 (15LA), or 9X5 (25LA).

4 Glowplug battery

The power source for heating the glowplug may be either a large heavy-duty 1.5volt dry cell, or preferably, a 2-volt rechargeable lead-acid cell (accumulator).

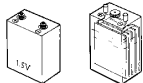

1.5 volt heavy-duty dry battery or 2 volt rechargeable lead-acid cell (at least 5Ah)

If a 2-volt cell is employed, use a resistance wire, as shown, to reduce applied voltage, otherwise element will overheat and burn out.

Warning (Very hot)

Never touch the nichrome wire while the battery is connected.

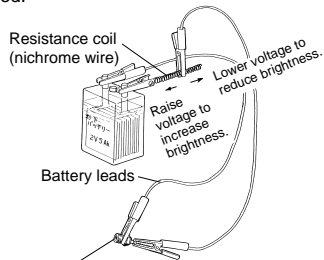

Adjust applied voltage by changing the position of clip on resistance coil until glowplug element is glowing bright red.

5 Plug wrench

Used for tightening glowplug. The O.S. long plug wrench is available as an optional accessory.

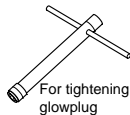

For tightening glowplug

6 Battery leads

These are used to conduct current from the battery to the glowplug. Basically, two leads, with clips, are required, but, for greater convenience, twin leads with special glowplug connectors, as shown on the right, are commercially available.



Battery leads

7 Fuel tank

For installation in the model, a 70cc(2.5oz.) for 10LA, a 100cc(3.5oz.) for 15LA, a 150cc(5oz.) for 25LA tank, is suggested.

8 Fuel bottle or pump

For filling the fuel tank, a simple, polyethylene "squeeze" bottle, with a suitable spout, is all that is required. Alternatively, one of the purpose-made manual or electric fuel pumps may be used to transfer fuel directly from your fuel container to the fuel tank.



Fuel bulb

Fuel pumps

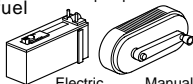

Electric

Manual

9 Fuel can filter

Fit a filter to the outlet tube of your refuelling container to prevent entry of foreign matter into the fuel tank. (Refer to ④ of STARTING THE ENGINE section.)



Fuel Can Filter

10 Silicone tubing

This is required for the connection between the fuel tank and engine.

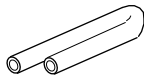

11 Electric starter and starter battery

An electric starter is recommended for starting.

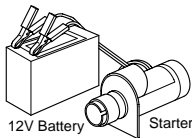

12V Battery

Starter

Fuel and pressure lines

Connect suitable lengths of silicone tubing, as illustrated, after installing the engine.

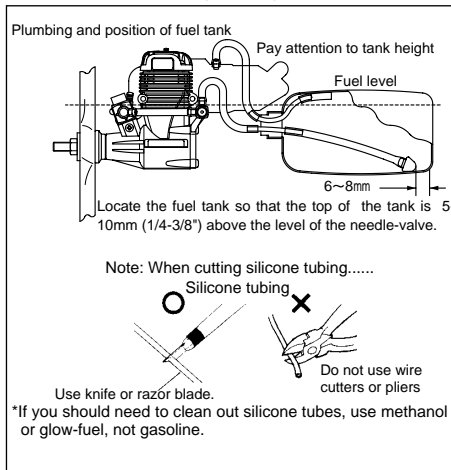

Silencer (muffler) pressurized fuel system

To reduce variation in fuel "head" and ensure steady fuel delivery at the carburettor, it is advisable to employ a silencer (muffler) pressurized fuel system, i.e. to use the silencer outlet nipple to pressurize the fuel tank as shown left.

ADVICE ON SELECTION OF FUEL, GLOWPLUG & PROPELLER

Fuel

Use a good quality commercial fuel or one of the blends shown in the table. Fuel "A" is suitable for running-in and ordinary use. Fuel "B" is for use when more power is required and for improved flexibility. Note that even a small quantity of nitromethane (3-5%) will improve flexibility, making the needle-valve adjustment less critical and improving throttle response. Use only materials of the highest purity. Synthetic oils are permissible but are less tolerant of a "lean run" than castor-oil. If, therefore, a synthetic lubricant is used in the fuel, readjust the needle-valve to a slightly richer setting, as a safety measure, in case the fuel/air mixture becomes too lean through maneuvers in flight. If a higher nitro fuel is used, the engine should be checked out to make sure that it is sufficiently run-in to operate on that particular fuel without overheating. Do not use fuels containing less than 18% lubricant.

	A	B
Methanol	75%	65%
Castor Oil	20%	20%
Nitromethane	5%	15%

Reminder!



Model engine fuel is poisonous. Do not allow it to come into contact with the eyes or mouth. Always store it in a clearly marked container and out of the reach of children.



Model engine fuel is also highly flammable. Keep it away from naked flame, excessive heat, sources of sparks, or anything else which might ignite it. Do not smoke, or allow anyone else to smoke, near to it.

PROPELLER

Suggested propeller sizes are given in the table. As the ideal propeller diameter, pitch and blade area vary according to the size, weight and type of model, final propeller selection can be made after practical experiment.

Reminder!



Never touch, or allow any object to come into contact with, the rotating propeller and do not crouch over the engine when it is running.

LA Series	Running-in	Trainer & Sport
10LA	7X4	7X3~5,8X4
15LA	8X4	7X5~6,8X4~5
25LA	9X5	9X5~6

GLOWPLUG

An O.S. A3 glowplug is fitted to the engine. Other recommended O.S. plugs are Nos.8 and A5. Carefully fit plug finger-tight, before final tightening with the correct size plug wrench.

The role of the glowplug

With a glowplug engine, ignition is initiated by the application of a 1.5-volt power source. When the battery is disconnected, the heat retained within the combustion chamber remains sufficient to keep the plug filament glowing, thereby continuing to keep the engine running. Ignition timing is 'automatic': under reduced load, allowing higher rpm, the plug becomes hotter and, appropriately, fires the fuel/air charge earlier; conversely, at reduced rpm, the plug become cooler and ignition is retarded.

Glowplug life

Particularly in the case of very high performance engines, glowplugs must be regarded as expendable. However, plug life can be extended and engine performance maintained by careful use, i.e.:

- Install a plug suitable for the engine.
- Use fuel containing a moderate percentage of nitromethane unless more is essential for racing events.
- Do not run the engine too lean and do not leave the battery connected while adjusting the needle.

When to replace the glowplug

Apart from when actually burned out, a plug may need to be replaced because it no longer delivers its best performance, such as when:

- Filament surface has roughened and turned white.
- Filament coil has become distorted.
- Foreign matter has adhered to filament or plug body has corroded.
- Engine tends to cut out when idling.
- Starting qualities deteriorate.

STARTING THE ENGINE

Preparations

① Installing the glowplug

Install washer on the glowplug and insert carefully into cylinder-head, making sure that it is not cross-threaded before tightening firmly.

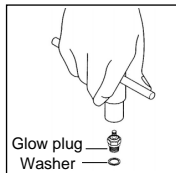

② Installing the propeller

First, install the propeller on the engine by tightening the prop nut or spinner-nut lightly, and make sure of the position where compression is felt, turning the propeller counter-clockwise slowly. Then tighten firmly as explained below.

For accurately centering the starter's rubber drive insert, install an O.S. solid alloy spinner-nut to the engine. (Available as an optional extra part).

Alternatively, a spinner assembly, enclosing the propeller boss, may be used, but make sure that it is of sturdy construction and that the spinner shell does not loosen when the starter is used.

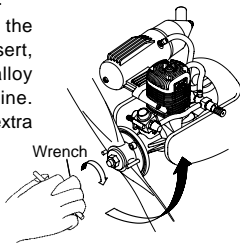

Warning: When using a spinner assembly, make sure that the notches in the spinner shell are large enough to clear the propeller blades and so do not cut into and weaken the blade roots.

Tighten the spinner nut firmly so that compression is first felt around this position (i.e. with blades horizontal) when turning the propeller in the direction of arrow.

③ Checking for gas leakage

Check gas leakage by turning the propeller up to this position after compression is felt.

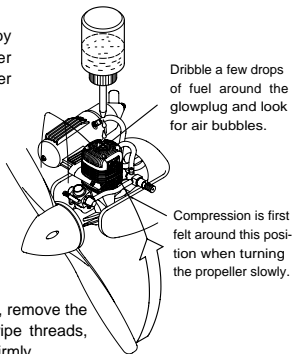

Dribble a few drops of fuel around the glowplug and look for air bubbles.

Compression is first felt around this position when turning the propeller slowly.

If leakage is detected, remove the glowplug, carefully wipe threads, re-insert and tighten firmly.

④ Filling the fuel tank

Do not allow fuel to overflow into silencer when refuelling, otherwise engine may become flooded and difficult to start.

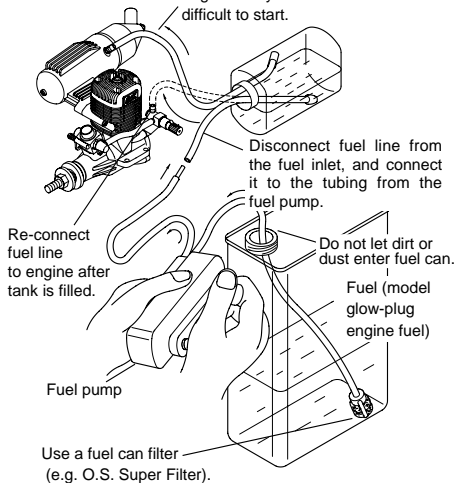

Disconnect fuel line from the fuel inlet, and connect it to the tubing from the fuel pump.

Re-connect fuel line to engine after tank is filled.

Do not let dirt or dust enter fuel can.

Fuel (model glow-plug engine fuel)

Fuel pump

Use a fuel can filter (e.g. O.S. Super Filter).

5 Opening and closing of the needle-valve

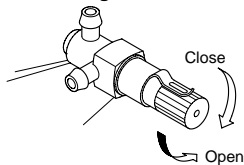

Turn needle-valve clockwise to close (for leaner mixture).
Turn needle-valve counter-clockwise to open (for richer mixture).

6 Setting the needle-valve

Open the needle-valve 4 turns (for 10LA), 3 turns (for 15LA),
1½ turns (for 25LA) in the direction of arrow from the closed
position.

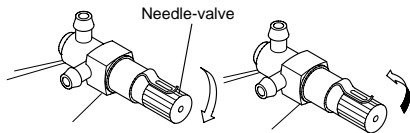

The position where the needle-valve stops is the fully closed
position. It may be convenient to remember the position of the
mark or set-screw at this time.

7 Open the throttle fully

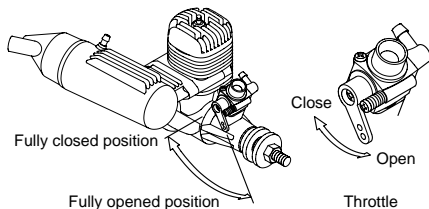

8 Priming

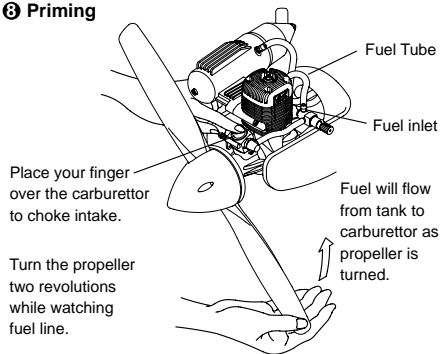

Place your finger
over the carburettor
to choke intake.

Turn the propeller
two revolutions
while watching
fuel line.

Fuel will flow
from tank to
carburettor as
propeller is
turned.

Priming quantity

After fuel has been drawn to the carburettor, flip the propeller two more revolutions, with intake choked, to draw fuel into engine.

Above procedure is called priming.

NOTE (IMPORTANT)

The quantity of fuel drawn into the engine by priming is an important factor in starting the engine successfully.

When the engine is being started for the first time, turn the propeller two revolutions after fuel reaches the fuel inlet, as described above. However, when re-starting the engine immediately after a run, one revolution, or even no priming at all may be required. The engine's requirements will be quickly learned with experience.

- 9 Do not energize the glowplug at this stage.

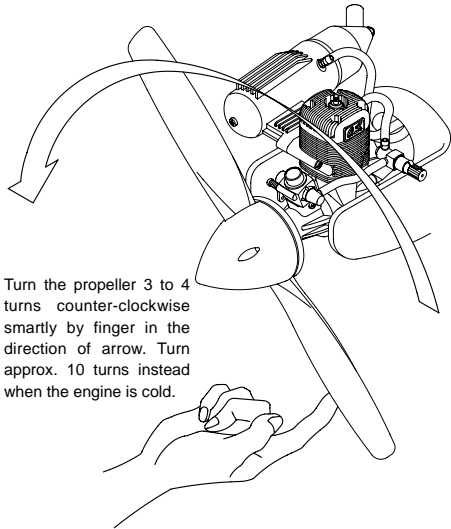

Turn the propeller 3 to 4 turns counter-clockwise smartly by finger in the direction of arrow. Turn approx. 10 turns instead when the engine is cold.

10 Hold model securely when starting

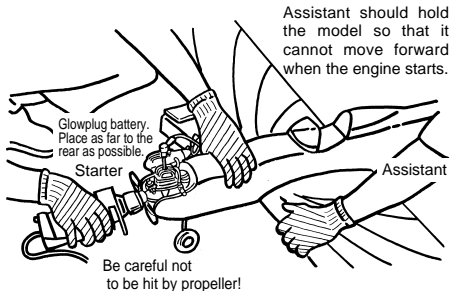

11 Setting the throttle

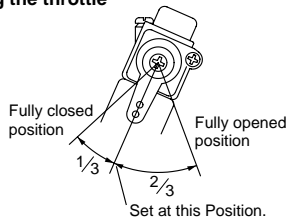

12 Heat glowplug

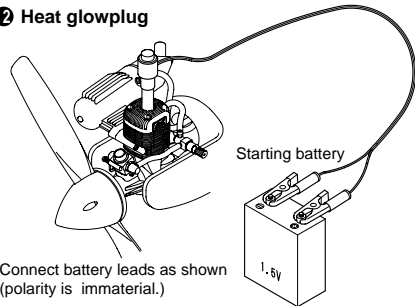

13 Apply electric starter

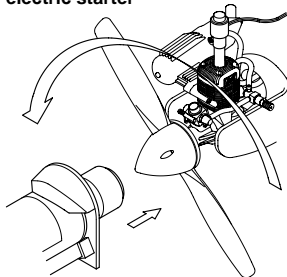

Check that the throttle is one-third open from the fully closed position. Bring the starter into contact with the spinner nut or spinner and depress the starter switch for one or two seconds. Repeat if necessary. When the engine fires, withdraw the starter immediately.

Attention: Never place your finger over the carburettor intake when applying the starter. Such an action will cause an excess quantity of fuel to be drawn into the cylinder and result in hydraulic lock that may damage the engine.

14 Engine starts

If the engine does not start, refer to the TROUBLE SHOOTING CHART on page 26-27.



BEWARE of
the rotating
propeller.

In the interests of safety, keep your face and other parts of the body away from the vicinity of the propeller.

15 Needle-valve adjustment(1)

Slowly advance throttle to its fully open position, then gradually close the needle-valve until the exhaust sound changes pitch.

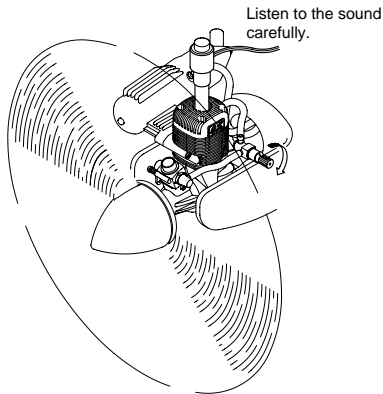

Close the needle-valve gradually until a high-pitched exhaust note begins to be superimposed on the lower-pitched sound.

16 Disconnect battery leads

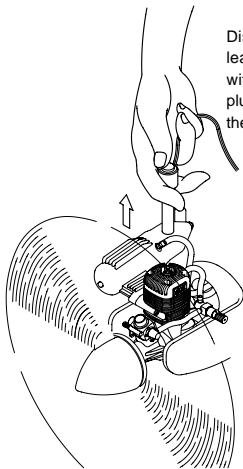

Disconnect the battery leads from the engine with care so that the plug clip does not touch the rotating propeller.

If the engine stops when battery leads are disconnected, close the needle-valve a little (approx. 30°) further, and restart the engine.

17 Needle-valve adjustment(2)

As the needle-valve is closed beyond the initial readjustment, the rpm of the engine will be increased and a continuous high-pitched exhaust note, only, will be heard.

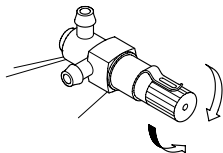

Key to the needle-valve adjustment.
(Turn 10-15° at a time.)

Turn the needle-valve 10-15° in the direction of arrow, and wait momentarily for the change of r.p.m.

After the rpm of the engine is increased, turn the needle-valve another 10-15° and wait for the next change of r.p.m.

As the speed of the engine does not instantly change with needle-valve readjustment, small movements, with pauses between, are necessary to arrive at the optimum setting.

IMPORTANT NOTE

When fine-tuning the needle-valve to reach peak performance, take care not to run the engine too lean and cause it to overheat.

Be sure to observe the simple running-in procedures described on Page 22.

18 Needle-valve adjustment(Summary)

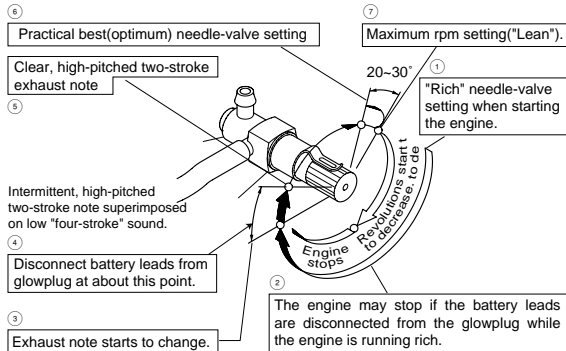

(Note: Although this is a two-stroke engine it fires like a four-stroke at these rich needle-valve settings-i.e. ignition of the fuel charge takes place at every fourth stroke of the piston instead of at every second stroke.)

NOTE: The above sketch is for reference purposes only.
Actual needle positions may differ from those shown.

On starting from cold, with the needle-valve set at the rich starting position:

a good deal of white smoke is emitted, accompanied by a relatively low-pitched "four-stroke" exhaust note.

As needle-valve is closed and rpm increases

an intermittent high-pitched two-stroke note will be superimposed on the low-pitched "four-stroke" note. Exhaust smoke will be less dense and grey in color.

Further needle-valve closure:

exhaust note is now a steady high-pitched sound, rising higher in pitch as needle-valve is closed and rpm increases. The grey smoke will be lighter. (However, make sure that engine is fully run in.)

Finally:

maximum rpm is reached and will fall off (or engine will stop) if needle -valve is closed any further. Exhaust gas will be very light.

Now, re-open needle-valve 20-30°

This will produce the practical best (i.e. optimum) rpm setting (lower than maximum rpm). A light grey exhaust emission may be observed.

Take note of this position of the needle-valve.

Subsequent starting procedure

Once the optimum needle-valve setting has been established (see 16 "Needle-valve adjustment-Summary") the procedure for starting is simplified as follows:

- 1) Open the needle-valve one half-turn (180°) from the optimum setting.
- 2) Open the throttle fully, place your finger over the carburettor intake and rotate the propeller through two revolutions to prime the engine.
- 3) Set the throttle one-third open from the fully closed position, energize the glowplug and apply the starter. When the engine starts, re-open the throttle and re-adjust the needle-valve to the optimum setting.

Note: When re-starting the engine on the same day, provided that atmospheric conditions have not changed significantly, it may be practicable to re-start the engine on its optimum (running) setting. Also, if the engine is being re-started immediately after a run (i.e.hot), priming should not be necessary.

19 How to stop the engine

Close the throttle to reduce to the lowest possible r.p.m.

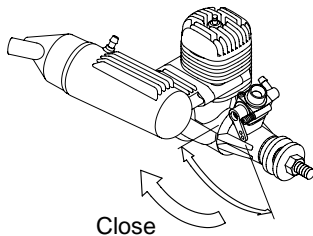

With the transmitter throttle trim lever fully retarded, adjust the throttle servo linkage so that the throttle rotor is fully closed (i.e.engine stopped) when the stick is fully retarded.

RUNNING-IN ("Breaking-in")

All internal-combustion engines benefit, to some degree, from extra care when they are run for the first few times - known as running-in or breaking-in. This is because the working parts of a new engine take a little time to settle down after being subjected to high temperatures and stresses. However, because O.S. engines are made with the aid of the finest modern precision machinery and from the best and most suitable materials, only a very short and simple running-in procedure is required and can be carried out with the engine installed in the model. The process is as follows:

- 1) Start the engine and, with the throttle fully open, open the needle-valve an extra half turn (180°) from the optimum setting. This will produce a rich mixture that will result in cooler running. Allow the engine to run out a full tank on the ground. (Avoid dusty surroundings.)
- 2) Now fly the model with the needle-valve re-set 20-30 degrees open from the optimum setting (i.e. $40-60^\circ$ from the highest rpm setting).
- 3) Close the needle-valve very slightly on successive flights so that the engine is running on its optimum needle setting at the fifth or sixth flight.

CARBURETTOR

These engines are equipped with a throttle type carburettor which provides a wide range of engine speed control. With the throttle lever linked to a suitable electric servo in the model, movement of the throttle control on the transmitter will enable engine rpm to be varied, proportionally, from idling speed to full power.

The carburettor of your engine has been factory set for the approximate best results and no adjustment (except to the needle-valve) should be required provided that the fuel tank is correctly located, as previously described. After the engine has been run-in, check the operation of the throttle according to the following chart. Re-adjust the controls only when necessary.

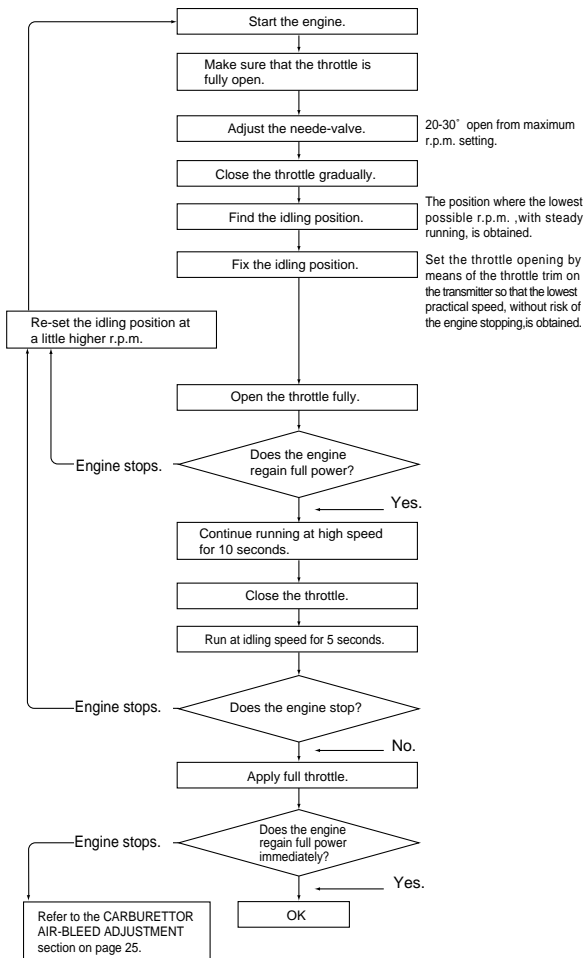

CARBURETTOR AIR-BLEED ADJUSTMENT

Pre-Flight Check

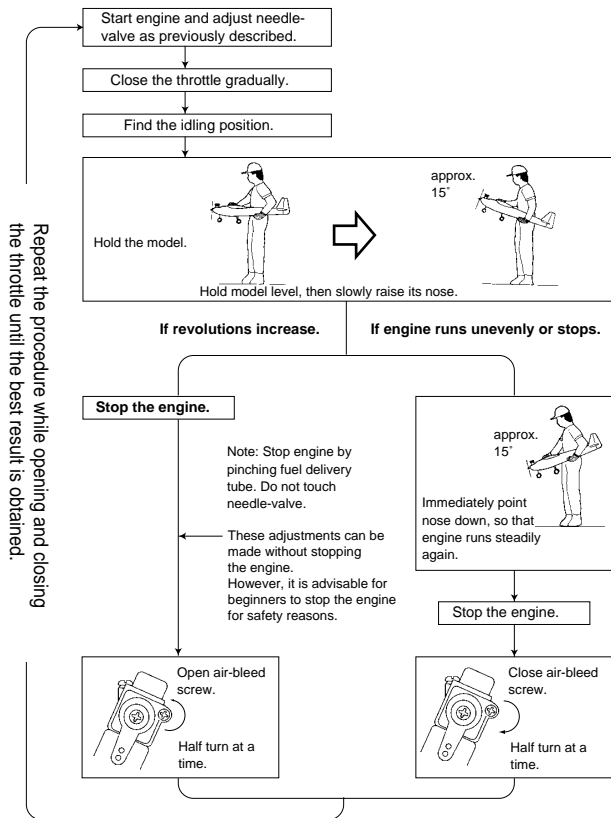

Attention: Do not leave the glowplug connected to the battery while adjusting the carburettor throttle.

TROUBLE SHOOTING WHEN THE ENGINE FAILS TO START

Four key points

For quick, reliable starting, the following four conditions are required.

- ① **Good compression.** ② **Adequate "glow" at glowplug.** ③ **Correct mixture.**
 ④ **Sufficient electric starter rotating speed.**

If the engine fails to start, or does not keep running after being started, check symptoms against the following chart and take necessary corrective action.

Note: The most common causes of trouble are marked with three asterisks, the less common problems with one or two asterisks.

Symptom	Factor	Cause	Corrective action
Engine fails to fire.	①	★ Sluggish rotation	Recharge the electric starter battery.
		★★ Glowplug battery discharged.	Recharge lead-acid cell or replace dry battery. (Note: An unused, or almost unused, dry battery may sometimes be of insufficient capacity if it is "old stock".)
	②	★ Glowplug element is burned out	Replace glowplug. Check that applied voltage is not too high.
		★ Something wrong with battery leads.	Check glowplug heating using other leads.
		★★ Engine "flooded" due to excessive priming.	Close needle-valve fully and remove glowplug, then flip propeller to pump out excess fuel. (Invert engine, if possible, while pumping out excess). Re-start engine. (Priming is not necessary at this time.)
	③	★★ Engine "flooded" due to excessive priming.	Close needle-valve fully and remove glowplug, then flip propeller to pump out excess fuel. (Invert engine, if possible, while pumping out excess). Re-start engine. (Priming is not necessary at this time.)
★ Insufficient priming.		Repeat priming procedure referring to ⑧ Priming.	

Symptom	Factor	Cause	Corrective action
Engine fires intermittently but does not run.	②—★★	Incorrect heating of glowplug.	· Voltage too high or too low. Re-check and readjust referring to "BEFORE STARTING" paragraph 4.
	③—★★	Over priming.	· Continue flipping propeller. If engine does not start after more than 10 flips, disconnect battery from glowplug and leave for a few minutes, then re-energize plug and flip prop again. If engine still does not start, remove glowplug and pump out excess fuel by flipping prop quickly.
	①—★	Sluggish rotation.	· Then re-start. (Priming is not necessary.) Recharge the electric starter battery.
Engine fires once or twice, then fails to fire.	②—★★	Glowplug battery discharged.	· Recharge lead-acid cell or replace dry battery. (Note: An unused, or almost unused, dry battery may sometimes be of insufficient capacity if it is "old stock".)
	③—★★	Insufficient priming.	· Repeat priming procedure referring to ③ Priming.
Engine starts but revolutions decrease and engine eventually stops.	③—★★★	Mixture too rich.	· Close needle-valve half turn (180°) and wait for several minutes then re-start.(Priming is not necessary.)
Engine starts, then revolutions increase and engine cuts out.	③—★	Fuel not reaching the engine.	· Make sure that tank is filled with fuel. Check that there is not something wrong with fuel tubing (kinked or split). Check that carburettor is not clogged with dirt.
Engine stops when battery leads are disconnected after starting.	③—★★	Mixture too rich.	· Close the needle-valve a little.
	②—★	Mismatch of glow plug and fuel.	· Change fuel or glowplug.

CARE AND MAINTENANCE

To ensure that you obtain long life and peak performance from your engine, observe the following.

1. Avoid running the engine under dusty conditions.
If necessary, lay a sheet of plywood or hard-board in front and under the nose of the model when starting the engine.
2. Foreign matter in the fuel can cause the carburettor jet to be partially clogged.

Therefore:

- rinse out the fuel tank with methanol or fuel before installing it.
- Install a fuel filter in the fuel line between tank and carburettor.
- Install a fuel filter in the outlet of your squeeze bottle, or in the pump inlet if you use a manual or electric pump.
- do not leave your fuel container open needlessly.
- check filters periodically and clean them when necessary.

3. Do not leave raw fuel in the engine at the conclusion of a flying session: it may cause corrosion. The best practice is to disconnect the fuel line from the carburettor while the engine is running. Remaining fuel in the tank should also be drained off.
4. Clean the exterior of the engine with a clean cotton cloth. If this is not done, oil and dirt will burn onto the outside of the engine each time it is run and the engine will soon become blackened.
5. If the engine is not in use for a while (more than two months) remove the glowplug and rinse out the interior with kerosene (not gasoline), by rotating the crankshaft. Shake out residue, then inject light machine-oil through the plug hole and carburettor intake, again rotating the shaft to distribute the protective oil to all working parts. Gasoline, thinner, kerosene and light machine oil cause swelling and deterioration of plastic parts, "O" rings and fuel tubing. Use methanol for cleaning these engines.
6. Avoid unnecessary dismantling of your engine.

O.S. GENUINE PARTS & ACCESSORIES

■ RADIAL MOTOR MOUNT

(71909110) for 10LA
(71909310) for 15LA
(71908100) for 25LA

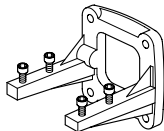

■ SILENCER EXTENSION ADAPTORS

(21125108) for 10/15LA
(22325100) for 25LA

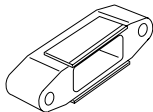

■ EXHAUST ADAPTORS

(21125502) for 10/15LA



■ GLOW PLUG

A3 (71605300)
No.8 (71608001)



■ NEEDLE VALVE EXTENSION CABLE SET

(72200080)

■ LONG PROPELLER NUT SET

(73101000) for 25LA



■ SUPER FILTER (L)

(72403050)



■ SPINNER NUT

M5 (20824005) for 10/15LA
1/4"-28 (23024008) for 25LA



■ NON-BUBBLE WEIGHT

(71531000)



■ LONG SOCKET WRENCH WITH PLUG GRIP

(71521000)

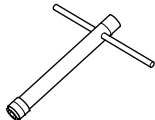

EXPLODED VIEW (MAX-10LA)

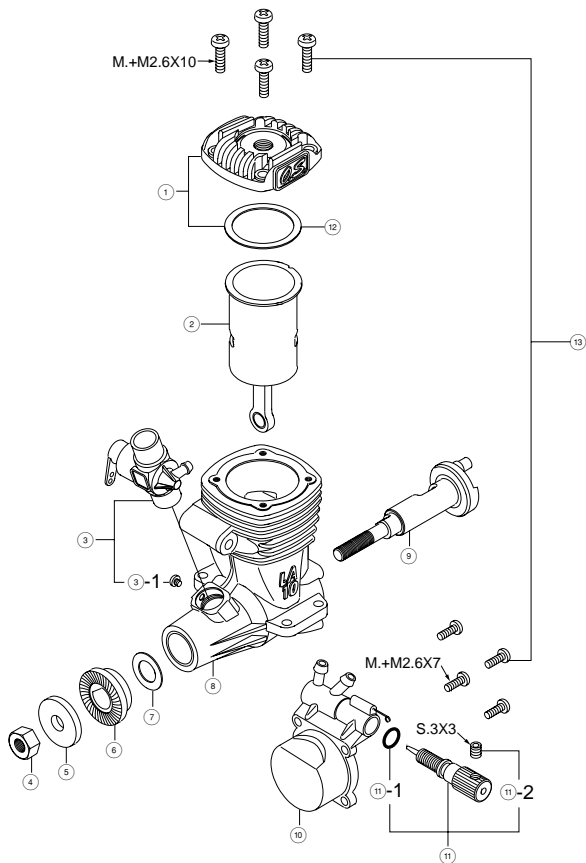

* Type of screw C··Cap Screw M··Oval Fillister-Head Screw
 F··Flat Head Screw N··Round Head Screw S··Set Screw

ENGINE PARTS LIST (MAX-10LA)

No.	Code No.	Description
①	2 1004 000	Cylinder Head
②	2 1003 000	Cylinder Piston & Connecting Rod Assembly
③	2 1081 000	Carburettor Complete 10H
③-1	2 7881 120	Carburettor Retaining Screw
④	2 0810 007	Propeller Nut
⑤	2 1109 005	Propeller Washer
⑥	2 1758 000	Drive Hub
⑦	2 1620 006	Thrust Washer
⑧	2 1001 000	Crankcase
⑨	2 1002 000	Crankshaft
⑩	2 1007 000	Cover Plate
⑪	2 1781 970	Needle
⑪-1	2 4981 837	"O" Ring
⑪-2	2 6381 501	Set Screw
⑫	2 1014 000	Head Gasket
⑬	2 1013 000	Screw Set
	7 1605 300	Glow Plug A3
	2 1225 000	871 Silencer
	2 2681 957	Pressure Fitting
	2 2325 300	Assembly Screw
	2 1125 409	Retaining Screw(N.+M2.6X25 2pcs.)

Specifications are subject to alteration for improvement without notice.

EXPLODED VIEW (MAX-15LA,25LA)

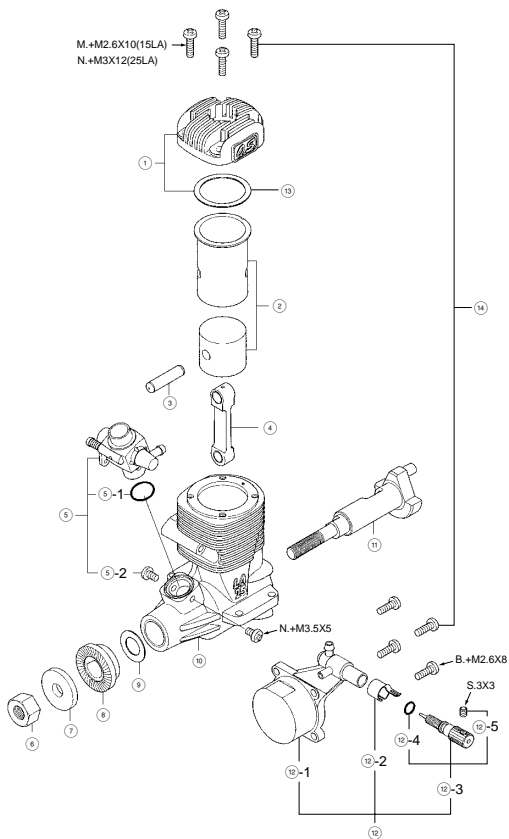

* Type of screw C...Cap Screw M...Oval Fillister-Head Screw
F...Flat Head Screw N...Round Head Screw S...Set Screw

ENGINE PARTS LIST (MAX-15LA,25LA)

	Code No.		Description
	15LA	25LA	
①	21754000	22554000	Cylinder Head
②	21753000	22553000	Cylinder & Piston Assembly
③	21706000	22606009	Piston Pin
④	21205040	22405013	Connecting Rod
⑤	21783000	—	Carburettor Complete (10G)
	—	22581000	Carburettor Complete (20H)
⑤-1	21015001	22615000	Carburettor Rubber Gasket
⑤-2	23081706		Carburettor Retaining Screw(2pcs.)
⑥	20810007	23210007	Propeller Nut
⑦	21109005	24009000	Propeller Washer
⑧	21758000	22558000	Drive Hub
⑨	21620006	22020001	Thrust Washer
⑩	21751000	22551000	Crankcase
⑪	21752000	22302000	Crankshaft
⑫	21757000	22557000	Cover Plate Assembly
⑫-1	21757100	22557100	Cover Plate
⑫-2	26711305		Ratchet Spring
⑫-3	21781970	24081970	Needle
⑫-4	24981837		"O" Ring
⑫-5	26381501		Set Screw
⑬	21714100	22564000	Head Gasket
⑭	21713000	22563000	Screw Set
	71605300		Glow Plug A3
	21225000	—	871 Silencer
	22681957	—	Pressure Fitting
	22325300	—	Assembly Screw
	21125409	—	Retaining Screw(N.+M2.6X25 2pcs.)
	—	22325020	E-2030 Silencer
	—	22625404	Retaining Screw(N.+M3X27 2pcs.)

Specifications are subject to alteration for improvement without notice.

CARBURETTOR EXPLODED VIEW & PARTS LIST

TYPE 10H

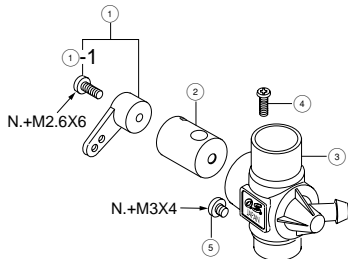

TYPE 10G,20H

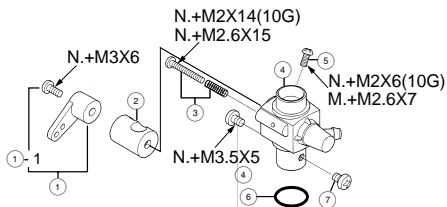

* Type of screw

C...Cap Screw M...Oval Fillister-Head Screw

F...Flat Head Screw N...Round Head Screw S...Set Screw

	Code No.	Description
①	2 1081 400	Throttle Lever Assembly
①-1	2 4081 300	Throttle Lever Fixing Screw
②	2 1081 200	Carburettor Rotor
③	2 1081 100	Carburettor Body
④	2 1081 300	Throttle Stop Screw
⑤	2 7881 120	Carburettor Retaining Screw

	Code No.		Description
	10G	20H	
①	22081408		Throttle Lever Assembly
①-1	22081313		Throttle Lever Fixing Screw
②	21781200	22381200	Carburettor Rotor
③	21783600	24081600	Air-bleed Screw
④	21783100	22581100	Carburettor Body
⑤	21783300	22581300	Throttle Stop Screw
⑥	21015001	22615000	Carburettor Gasket
⑦	23081706		Carburettor Retaining Screw

Specifications are subject to alteration for improvement without notice.

MAX-10LA THREE VIEW DRAWING

10LA SPECIFICATIONS

■ Displacement	1.76 cc (0.107 cu.in.)
■ Bore	13.44mm (0.529 in.)
■ Stroke	12.4mm (0.488 in.)
■ Practical R.P.M.	2,500~18,000 r.p.m.
■ Power output	0.27 bhp / 17,000 r.p.m.
■ Weight	112g (3.95 oz.)

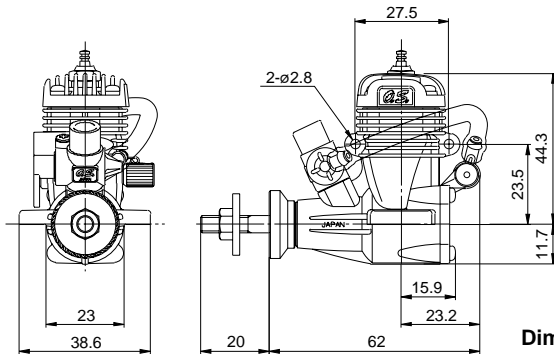
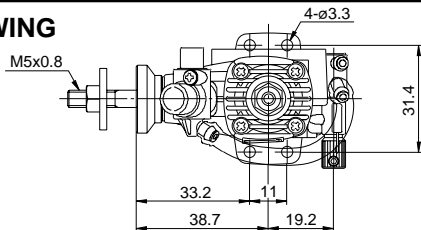

Dimensions(mm)

MAX-15LA/25LA THREE VIEW DRAWING Dimensions(mm)

15LA SPECIFICATIONS

■ Displacement	2.49 cc (0.1517 cu.in.)
■ Bore	15.2mm (0.598 in.)
■ Stroke	13.7mm (0.539 in.)
■ Practical R.P.M.	2,500~18,000 r.p.m.
■ Power output	0.41 bhp / 17,000 r.p.m.
■ Weight	138g (4.87 oz.)

25LA SPECIFICATIONS

■ Displacement	4.07 cc (0.249 cu.in.)
■ Bore	18.0mm (0.709 in.)
■ Stroke	16.0mm (0.630 in.)
■ Practical R.P.M.	2,500~16,000 r.p.m.
■ Power output	0.6 bhp / 15,000 r.p.m.
■ Weight	197g (6.94 oz.)

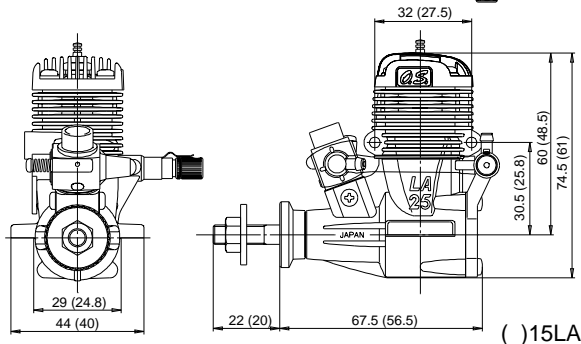
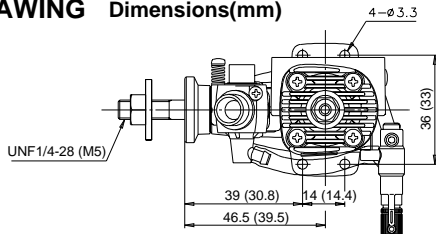



O.S. ENGINES MFG.CO.,LTD.

6-15 3-Chome Imagawa Higashisumiyoshi-ku
Osaka 546-0003, Japan TEL. (06) 6702-0225
FAX. (06) 6704-2722