

O.S. ENGINE**MAX-108FSR RING <BX-1> (RN)**

OWNER'S INSTRUCTION MANUAL

It is of vital importance, before attempting to operate your engine, to read the general **'SAFETY INSTRUCTIONS AND WARNINGS'** section on pages 2-6 of this booklet and to strictly adhere to the advice contained therein.

- Also, please study the entire contents of this instruction manual, so as to familiarize yourself with the controls and other features of the engine.
- Keep these instructions in a safe place so that you may readily refer to them whenever necessary.
- It is suggested that any instructions supplied with the aircraft, radio control equipment, etc., are accessible for checking at the same time.

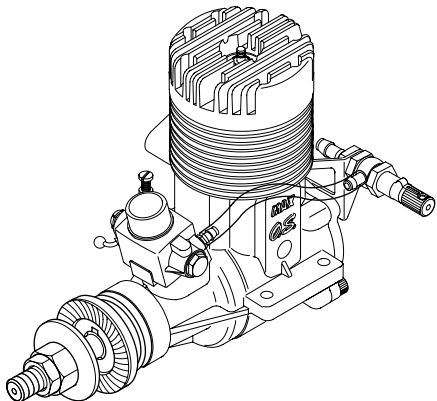

CONTENTS

SAFETY INSTRUCTIONS AND WARNINGS ABOUT YOUR O.S. ENGINE -----	2~6	RUNNING-IN (Breaking-in) -----	15~17
INTRODUCTION, BEFORE INSTALLING THE ENGINE -----	7	IDLING ADJUSTMENT CHART -----	18
BASIC ENGINE PARTS INSTALLATION OF THE ENGINE -----	8~9	MIXTURE CONTROL VALVE ADJUSTMENT -----	19
THROTTLE LINKAGE, SILENCER -----	10	SUBSEQUENT STARTING PROCEDURE SUBSEQUENT READJUSTMENT -----	20
FUEL TANK LOCATION -----	11	CARBURETOR CLEANLINESS, ENGINE CARE AND MAINTENANCE -----	21
GLOWPLUG -----	11~12	ENGINE EXPLODED VIEWS & ENGINE PARTS LISTS -----	22~23
FUEL, PROPELLERS -----	12~13	CARBURETOR EXPLODED VIEWS & PARTS LISTS -----	24
CARBURETOR CONTROLS -----	13~14	ENGINE THREE VIEW DRAWINGS -----	25
STARTING -----	14~15	GENUINE O.S. PARTS & ACCESSORIES -----	26

SAFETY INSTRUCTIONS AND WARNINGS ABOUT YOUR O.S. ENGINE

Remember that your engine is not a "toy", but a highly efficient internal-combustion machine whose power is capable of harming you, or others, if it is misused.

As owner, you, alone, are responsible for the safe operation of your engine, so act with discretion and care at all times.

If at some future date, your O.S. engine is acquired by another person, we would respectfully request that these instructions are also passed on to its new owner.

- The advice which follows is grouped under two headings according to the degree of damage or danger which might arise through misuse or neglect.



WARNINGS

These cover events which might involve serious (in extreme circumstances, even fatal) injury.



NOTES

These cover the many other possibilities, generally less obvious sources of danger, but which, under certain circumstances, may also cause damage or injury.



WARNINGS

- Never touch, or allow any object to come into contact with, the rotating propeller and do not crouch over the engine when it is running.



- A weakened or loose propeller may disintegrate or be thrown off and, since propeller tip speeds with powerful engines may exceed 600 feet(180 metres) per second, it will be understood that such a failure could result in serious injury, (see 'NOTES' section relating to propeller safety).

- Model engine fuel is poisonous. Do not allow it to come into contact with the eyes or mouth. Always store it in a clearly marked container and out of the reach of children.



- Model engine fuel is also highly flammable. Keep it away from open flame, excessive heat, sources of sparks, or anything else which might ignite it. Do not smoke or allow anyone else to smoke, near to it.



- Never operate your engine in an enclosed space. Model engines, like automobile engines, exhaust deadly carbon-monoxide. Run your engine only in an open area.
- Model engines generate considerable heat. Do not touch any part of your engine until it has cooled. Contact with the muffler (silencer), cylinder head or exhaust header pipe, in particular, may result in a serious burn.





NOTES

- This engine was designed for model aircraft. Do not attempt to use it for any other purpose.
- Mount the engine in your model securely, following the manufacturers' recommendations, using appropriate screws and lock-nuts.
- Be sure to use the silencer (muffler) supplied with the engine. Frequent exposure to an open exhaust may eventually impair your hearing. Such noise is also likely to cause annoyance to others over a wide area.
- If you remove the glowplug from the engine and check its condition by connecting the battery leads to it, do not hold the plug with bare fingers. Use an appropriate tool or a folded piece of cloth.
- Install a top-quality propeller of the diameter and pitch specified for the engine and aircraft. Locate the propeller on the shaft so that the curved face of the blades faces forward-i.e. in the direction of flight. Firmly tighten the propeller nut, using the correct size wrench.



NOTES

- Always check the tightness of the propeller nut and retighten it, if necessary, before restarting the engine, particularly in the case of four-stroke-cycle engines. If a safety locknut assembly is provided with your engine, always use it. This will prevent the propeller from flying off in the event of a "backfire", even if it loosens.
- If you fit a spinner, make sure that it is a precision made product and that the slots for the propeller blades do not cut into the blade roots and weaken them.
- Preferably, use an electric starter. The wearing of safety glasses is also strongly recommended.
- Discard any propeller which has become split, cracked, nicked or otherwise rendered unsafe. Never attempt to repair such a propeller: destroy it. Do not modify a propeller in any way, unless you are highly experienced in tuning propellers for specialized competition work such as pylon-racing.
- Take care that the glow plug clip or battery leads do not come into contact with the propeller. Also check the linkage to the throttle arm. A disconnected linkage could also foul the propeller.
- After starting the engine, carry out any needle-valve readjustments from a safe position behind the rotating propeller. Stop the engine before attempting to make other adjustments to the carburetor.



NOTES

- Adjust the throttle linkage so that the engine stops when the throttle stick and trim lever on the transmitter are fully retarded. Alternatively, the engine may be stopped by cutting off the fuel supply. Never try to stop the engine physically.
- Take care that loose clothing (ties, shirt sleeves, scarves, etc.) do not come into contact with the propeller. Do not carry loose objects (such as pencils, screwdrivers, etc.) in a shirt pocket from where they could fall through the propeller arc.
- Do not start your engine in an area containing loose gravel or sand. The propeller may throw such material in your face and eyes and cause injury.
- For their safety, keep all onlookers (especially small children) well back (at least 20 feet or 6 meters) when preparing your model for flight. If you have to carry the model to the take-off point with the engine running, be especially cautious. Keep the propeller pointed away from you and walk well clear of spectators.
- Warning! Immediately after a glowplug-ignition engine has been run and is still warm, conditions sometimes exist whereby it is just possible for the engine to abruptly restart if the propeller is casually flipped over compression WITHOUT the glowplug battery being reconnected. Remember this if you wish to avoid the risk of a painfully rapped knuckle!

INTRODUCTION

- This engine is ideally suited to a variety of R/C aircraft, including sports and scale types.
- A separate precision-made needle-valve unit is installed at the rear, where manual adjustment is safely remote from the rotating propeller.
- An effective low-loss 855 silencer is supplied.

BEFORE INSTALLING THE ENGINE

In addition to the general tools, the following tools are convenient to use.

- 10mm wrench to secure nuts, preferably 2 pcs.
- 14-17mm open end wrench
- Large capacity electric starter and battery

Installing the glowplug

Carefully insert plug, with washer, fingertight only, before final tightening with the correct size plug wrench.



Installing the remote needle

- Install the remote needle to the attachment bracket as shown in the following.
- First, make sure that nut A and B are secured using a 10mm wrench. Then, fit the remote needle to the attachment bracket, and tighten nut A and C.

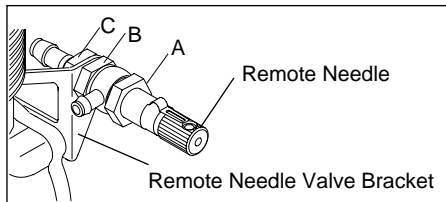

Connect the needle-valve to carburetor jet nozzle with silicone tubing supplied. In the event of the tubing becoming damaged, it should be replaced with 78mm length of 5mm ODx2mm ID silicone tubing.

BASIC ENGINE PARTS

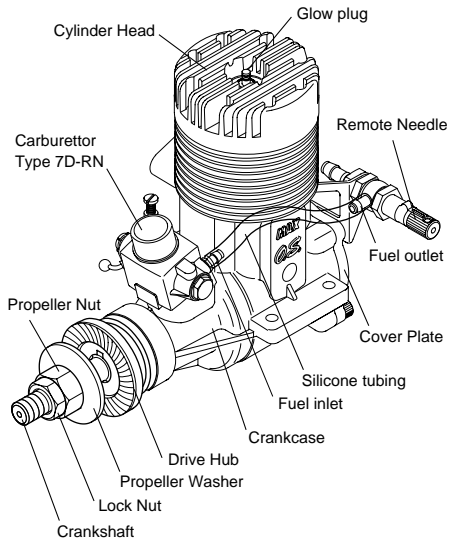

INSTALLATION OF THE ENGINE

Installation in the model

A typical method of beam mounting is shown below, left.

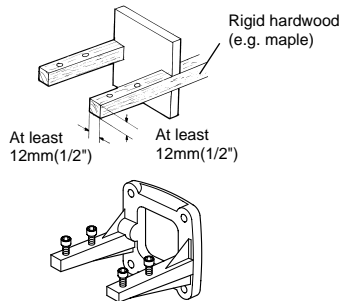

O.S. radial motor mount
(Available as an optional extra part. See parts list)

For 108FSR(BX-1) (Code No. 71907000)

Make sure that the mounting beams are parallel and that their top surfaces are in the same plane.

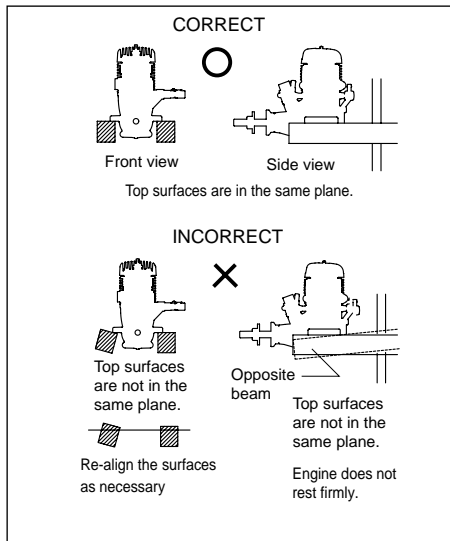

How to fasten the mounting screws.

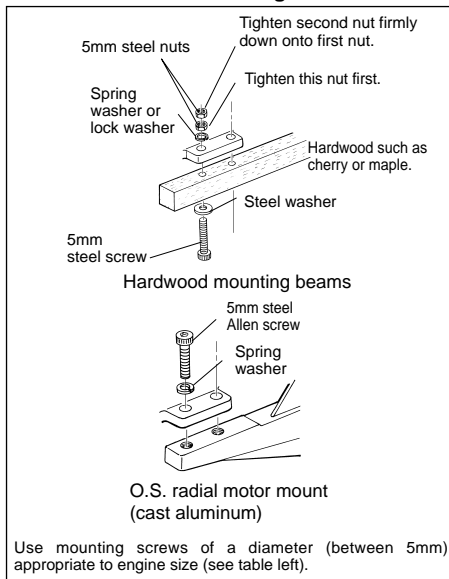

THROTTLE LINKAGE

- Before connecting the throttle-lever / servo linkage, make sure that no part of the linkage interferes with the internal structure of the aircraft or wiring, etc., when the throttle is fully open or fully closed.
- Set the throttle lever linkage so that the throttle rotor is (a) fully open when the transmitter throttle stick is fully advanced and (b) fully closed when the throttle stick is fully retarded. Adjustment of the throttle rotor opening at the idling position can then be made with the throttle trim lever on the transmitter. (Select throttle-lever and servo-horn hole positions that will avoid excessive pushrod travel causing the throttle to bind at either end.)

SILENCER

The exhaust outlet of the silencer can be rotated to any desired position in the following manner:

- 1) Loosen the locknut and assembly screw.
- 2) Set the exhaust outlet at the required position by rotating the rear part of the silencer.
- 3) Re-tighten the assembly screw, followed by the locknut.

Instaall the silencer as follows.

1. Install the exhaust adapter to the engine with three (3) fixing screw provided (M4x15 2pcs., M3.5x12 1pc.)
2. Secure the silencer to the exhaust adapter with fixing screw (M4x18 Allen screw) using 3.0mm Allen key.

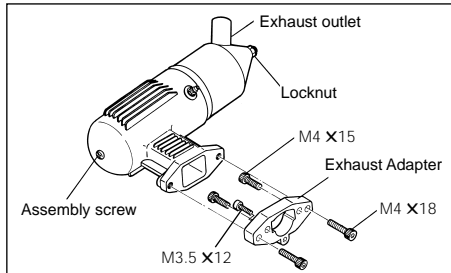

Model engines generate considerable heat. Do not touch any part of your engine until it has cooled. Contact with the muffler (silencer), cylinder head or exhaust header pipe, in particular, may result in a serious burn.



FUEL TANK LOCATION

For installation in the model a 500cc tank is suggested. These will allow 10-12 minute flights. Locate the fuel tank so that the top of the tank is 5-10mm (1/4-3/8") above the level of the needle-valve.

- Be sure to use a pressurized fuel system by connecting the muffler pressure nipple to the vent-pipe of the fuel tank.

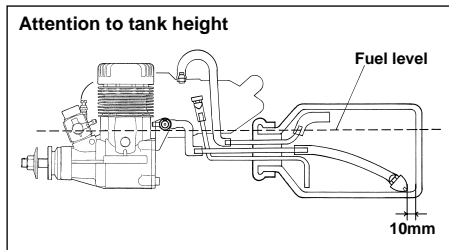

GLOWPLUG

Since the glowplug and fuel combination used may have a marked effect on performance and reliability, it would be worthwhile to experiment with different plug types.

Recommended O.S. plug is No8.

Carefully install plug finger-tight, before final tightening with the correct size plug wrench.

The role of the glowplug

With a glowplug engine, ignition is initiated by the application of a 1.5-volt power source. When the battery is disconnected, the heat retained within the combustion chamber remains sufficient to keep the plug filament glowing, thereby continuing to keep the engine running. Ignition timing is 'automatic' : under reduced load, allowing higher rpm, the plug becomes hotter and, appropriately, fires the fuel/air charge earlier; conversely, at reduced rpm, the plug become cooler and ignition is retarded.

Glowplug life

Particularly in the case of very high performance engines, glowplugs must be regarded as expendable items.

However, plug life can be extended and engine performance maintained by careful use, i.e.:

- Install a plug suitable for the engine.
- Use fuel containing a moderate percentage of nitromethane unless more is essential for racing events.
- Do not run the engine too lean and do not leave the battery connected while adjusting the needle.

When to replace the glowplug

Apart from when actually burned out, a plug may need to be replaced because it no longer delivers its best performance, such as when:

- Filament surface has roughened and turned white.
- Filament coil has become distorted.
- Foreign matter has adhered to filament or plug body has corroded.
- Engine tends to cut out when idling.
- Starting qualities deteriorate.

FUEL

Select, by practical tests, the most suitable fuel from among the best quality fuels available in your country for model use. For the best performance, a fuel containing 5% to 20% nitromethane is preferable. Lubricants may be either castor-oil or a suitable synthetic oil (or a blend of both) provided that they are always of top quality.

For consistent performance and long engine life, it is essential to use fuel containing **AT LEAST 18%** lubricant by volume. Some fuels containing coloring additives tend to deteriorate and may adversely affect running qualities.

Once a satisfactory fuel has been selected and used for a while, it may be unwise to needlessly change the brand or type. In any engine, a change of fuel may cause carbon deposits in the combustion chamber or on the piston head to become detached and lodged elsewhere, with the risk of this causing unreliable operation for a while. If, however, the adoption of a different fuel is unavoidable, check the engine for the first few flights on the new fuel, by temporarily reverting to the running-in procedure.

Reminder!



Model engine fuel is poisonous. Do not allow it to come into contact with the eyes or mouth. Always store it in a clearly marked container and out of the reach of children.

Reminder!



Model engine fuel is also highly flammable. Keep it away from open flame, excessive heat, sources of sparks, or anything else which might ignite it. Do not smoke, or allow anyone else to smoke, near to it.

PROPELLERS

Suggested propeller sizes are listed on page 15. The suitability of the prop depends on the size and weight of the model and type of flying. Determine the best size and type after the engine has been run in. Check the balance of the propeller before fitting it to the engine. Unbalanced propellers cause vibration and loss of power. Wooden propellers are to be preferred. Some nylon propellers are not strong enough to withstand the high power output of these engines and a thrown blade can be very dangerous.

For Scale

14x6-8, 15x6-8, 16x6, 18x6

Reminder!



Never touch, or allow any object to come into contact with, the rotating propeller and do not crouch over the engine when it is running.

CARBURETOR CONTROLS (7D-RN)

Three adjustable controls are provided on this carburetor.

- **The Needle-Valve:(at rear of engine)**
For adjusting the mixture strength when the throttle is fully open.
- **The Mixture Control Screw:**
For adjusting the mixture strength at part-throttle and idling speeds, to obtain steady idling and smooth acceleration to mid speeds.
- **The Throttle Stop Screw:**
For setting the position where the carburetor rotor is closed..

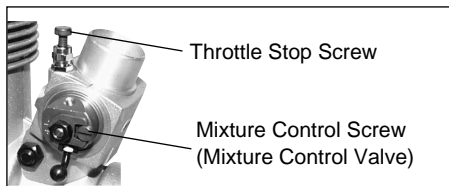

NOTE:

Readjustment may be necessary, occasionally to allow for changes in fuel formulae, gear ratio or clutch engagement point.

STARTING

1. Install an appropriate propeller and tighten securely.
2. To facilitate electric starting, fit a spinner for centring the rubber drive insert of the starter.
3. Fill the fuel tank. Do not allow fuel to overflow into the silencer, otherwise the engine may become flooded and difficult to start.

4. Check that the needle-valve is closed. (Do not overtighten.) Now open the needle-valve $1\frac{1}{2}$ -2 turns from the fully closed position and temporarily set the throttle in the fully open position.

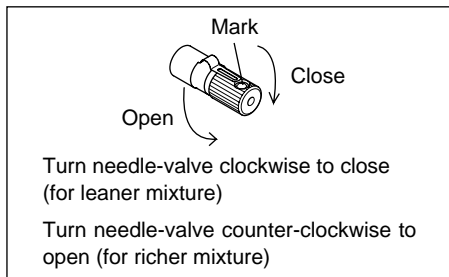

5. Open the throttle approx.

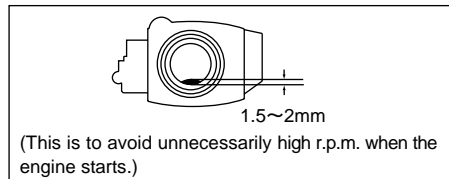

6. Connect battery leads to glowplug.
7. Bring electric starter into contact with spinner-nut or spinner and depress starter switch for one or two seconds. Repeat if necessary.
When the engine starts, withdraw the starter immediately.

Attention :

Do not choke the carburettor air intake when applying the starter. This could cause an excessive amount of fuel to be drawn into the cylinder which may initiate an hydraulic lock and damage the engine.

If the engine does not start within 10 repeat applications of the starter, remove the glow-plug, check that it glows brightly and that the cylinder is not flooded with fuel. (To eject excess fuel, close needle-valve and apply starter with glowplug removed.) Then try again.

VERY IMPORTANT!

Before being operated at full power (i.e. at full-throttle and with the needle-valve closed to its optimum setting) the engine must be adequately run-in, otherwise there is a danger of it becoming overheated and damaged.

RUNNING-IN ("Breaking-in")

All internal-combustion engines benefit from extra care when they are run for the first few times known as running-in or breaking-in.

This allows the working parts to mate together under load at operating temperature. Therefore, it is vitally important to complete the break-in before allowing the engine to run continuously at high speed and before finalizing carburetor adjustments.

However, because O.S. engines are produced with the aid of the finest modern precision machinery and from the best and most suitable materials, only a short and simple running-in procedure is called for and can be carried out with the engine installed in the model. The process is as follows.

1. Install the engine with the propeller intended for your model. Open the needle-valve to the advised starting setting and start the engine. If the engine stops when the glow plug battery disconnected, open the needle-valve to the point where the engine does not stop. Run the engine for one minute with the throttle fully open, but with the needle-valve adjusted for rich, slow "four-cycle" operation.

2. Now close the needle-valve until the engine speeds up to "two-cycle" operation and allow it to run for about 10 seconds, then reopen the needle-valve to bring the engine back to "four-cycle" operation and run it for another 10 seconds. Repeat this procedure until the fuel tank is empty.
3. Re-start and adjust the needle-valve so that the engine just breaks into "two-cycle" from "four-cycle" operation, then make three or four flights, avoiding successive "nose-up" flights.
4. During subsequent flights, the needle-valve can be gradually closed to give more power. However, if the engine shows signs of running too lean, the next flight should be set rich. After a total of ten to fifteen flights, the engine should run continuously, on its optimum needle-valve setting, without loss of power as it warms up.
5. After the completion of the running-in adjust the carburetor at optimum setting referring to MIXTURE CONTROL VALVE ADJUSTMENT section and SUBSEQUENT READJUSTMENT section.

Optimum needle setting(1)

Slowly advance the throttle to its fully open position, then gradually close the needle-valve until the exhaust note begins to change. (4-cycle to 2-cycle) At this point, disconnect the battery from the glowplug, taking care that the battery leads or glowplug clip do not come into contact with the rotating propeller. If the engine stops when the battery is disconnected, close the needle-valve about 30° and restart.

Optimum needle setting(2)

As the needle-valve is closed slowly and gradually, the engine r.p.m. will increase and a continuous high-pitched exhaust note, only, will be heard. Close the needle-valve 10-15° and wait for the change of r.p.m. After the engine r.p.m. increases turn the needle-valve another 10-15° and wait for the next change of r.p.m. As the speed of the engine does not instantly change with needle-valve readjustment, small movements, with pauses between, are necessary to arrive at the optimum setting.

Needle-valve adjustment diagram

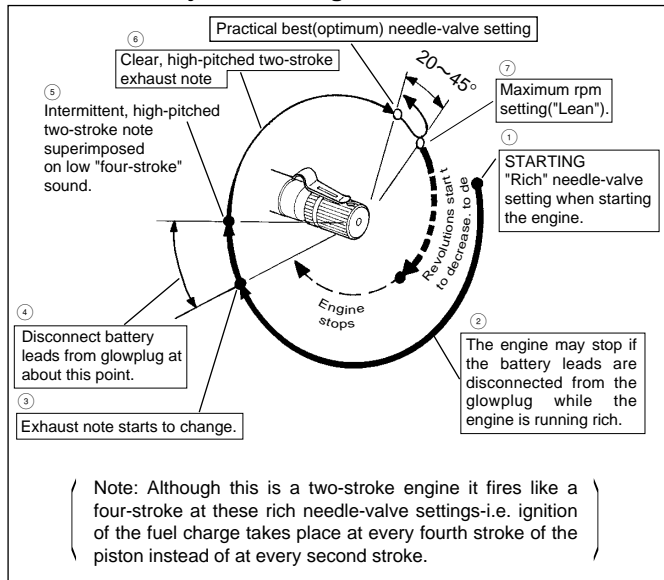

Note :

This diagram is for reference purposes only.

Actual needle positions may differ from those shown.

- To stop the engine, close the throttle completely to cut off fuel/air supply.

IDLING ADJUSTMENT CHART

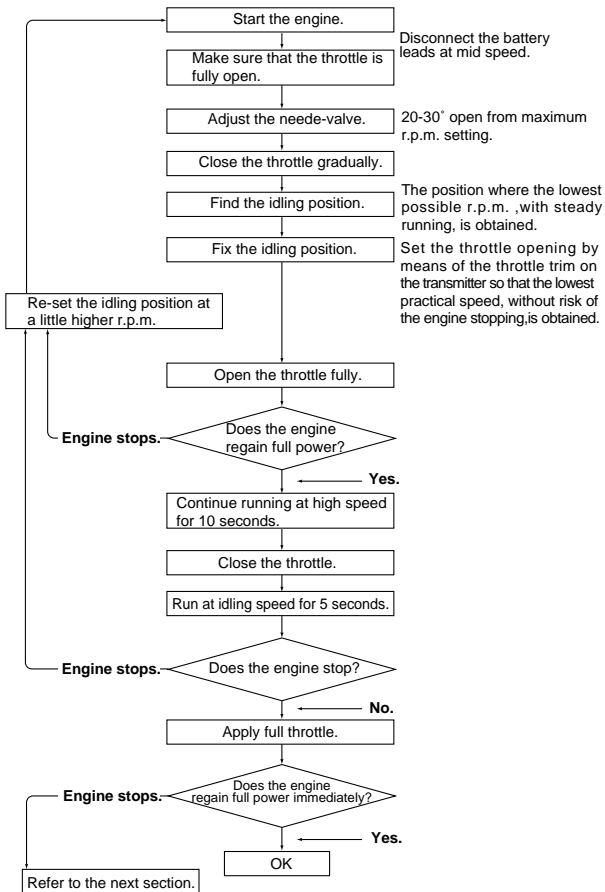

MIXTURE CONTROL VALVE ADJUSTMENT

With the engine running, close the throttle and allow it to idle for about five seconds, then open the throttle fully. If, at this point, the engine is slow to pick up and produces an excess of exhaust smoke, the mixture is too rich. Correct this condition by turning the Mixture Control Screw clockwise 10-20°. If the mixture is excessively rich, engine rpm will become unstable: opening the throttle will produce a great deal of smoke and rpm may drop suddenly or the engine may stop. This condition may also be initiated by excessively prolonged idling.

If, on the other hand, the mixture is too lean, this will be indicated by a marked lack of exhaust smoke and a tendency for the engine to cut out when the throttle is opened. In this case, turn the Mixture Control Screw counter-clockwise 90° to positively enrich the idle mixture, then turn the screw clockwise gradually until the engine regains full power cleanly when the throttle is reopened.

Carry out adjustments patiently until the engine responds quickly and positively to the throttle control.

Note: Mixture Control Valve adjustments should be made in steps of 10-20° initially, carefully checking the effect, on throttle response, of each small adjustment.

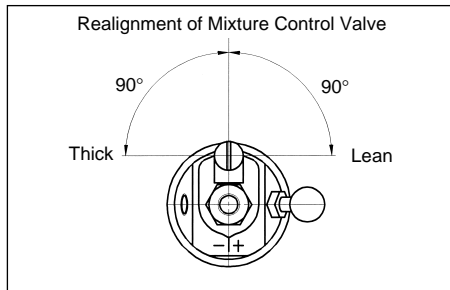

SUBSEQUENT STARTING PROCEDURE

Once the optimum needle-valve setting has been established (see page 17, Needle-valve adjustment diagram) the procedure for starting may be simplified as follows.

1. Open the needle-valve one half-turn (180°) from the optimum setting.
2. Set the throttle one-quarter open from the fully closed position, energize the glowplug and apply the electric starter. When the engine starts, re-open the throttle and re-adjust the needle-valve to the optimum setting.

Note:

When re-starting the engine on the same day, provided that atmospheric conditions have not changed significantly, it may be practicable to re-start the engine on its optimum(running) setting.

SUBSEQUENT READJUSTMENT

Once the engine has been run-in and the controls properly set up, it should be unnecessary to alter the mixture settings; except to make minor adjustments to the Needle-Valve occasionally, to take account of variations in climatic conditions.

The use of a different fuel, however, particularly one containing more, or less, nitromethane and/or a different type or proportion of lubricating oil, is likely to call for some readjustment of the Needle-Valve.

Remember that, as a safety measure, it is advisable to increase the Needle-Valve opening by an extra half-turn counter-clockwise, prior to establishing a new setting. The same applies if the silencer type is changed.

A different silencer may alter the exhaust pressure applied to the fuel feed and call for a revised Needle-Valve setting. The use of a different glowplug may also require compensating carburetor readjustments.

CARBURETOR CLEANLINESS

The correct functioning of the carburetor depends on its small fuel orifices remaining clear. The minute particles of foreign matter that are present in any fuel, can easily partially obstruct these orifices and upset mixture strength so that engine performance becomes erratic and unreliable.

O.S.'Super-Filters'(large and small) are available, as optional extras, to deal with this problem.

One of these filters, fitted to the outlet tube inside your refueling container, will prevent the entry of foreign material into the fuel tank.

It is also recommended that a good in-line filter be installed between the tank and needle-valve.

Do not forget to clean the filters regularly to remove dirt and lint that accumulate on the filter screen.

Also, clean the carburetor itself occasionally.

ENGINE CARE AND MAINTENANCE

1. At the end of each operating session, drain out any fuel that may remain in the fuel tank.
2. Next, energize the glowplug and try to restart the engine to burn off any fuel that may remain inside the engine. Repeat this procedure until the engine fails to fire. Remove the glowplug and eject any residue by rotating the engine with an electric starter for 4 to 5 seconds while the engine is still warm.
3. Finally, inject some after-run oil into the engine. Rotate the engine a few times by hand, to make sure that it is free, and then with an electric starter for 4 to 5 seconds to distribute the oil to all the working parts.

Note:

Do not inject after-run oil into the carburetor as this may cause the O-ring inside the carburettor to deteriorate.

These procedures will reduce the risk of starting difficulties and of internal corrosion after a period of storage.

EXPLODED VIEW

—22—

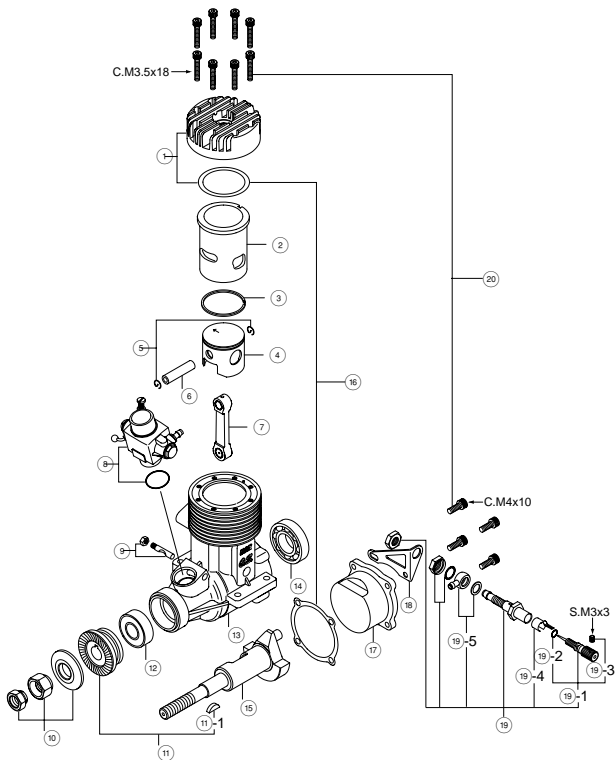

* Type of screw

C...Cap Screw F...Flat Head Screw N...Round Head Screw S...Set Screw

ENGINE PARTS LIST

No.	Code No.	Description
①	29204000	Cylinder Head
②	29203100	Cylinder Liner
③	29203400	Piston Ring
④	29203200	Piston
⑤	29206000	Piston Pin
⑥	29017004	Piston Pin Retainer
⑦	29205000	Connecting Rod
⑧	29081010	Carburettor Complete(Type 7D-RN)
⑨	29081719	Carburettor Retainer
⑩	29610100	Locknut Set
⑪	29208020	Drive Hub
⑪-1	29208200	Woodruff Key
⑫	29031009	Crankshaft Ball Bearing(Front)
⑬	29201000	Crankcase
⑭	46030008	Crankshaft Ball Bearing(Rear)
⑮	29202020	Crankshaft
⑯	29214000	Gasket Set
⑰	29007005	Cover Plate
⑱	71704240	Remote Needle Valve Bracket(108FSR)
⑱	28282000	Remote Needle Valve Assembly
⑱-1	28281970	Needle
⑱-2	24981837	"O" Ring
⑱-3	26381501	Set-screw
⑱-4	26711305	Ratchet Spring
⑱-5	46181950	Fuel Outlet
⑳	29213000	Screw Set
	71608001	Clow Plug No.8
	29025000	855 Silencer Assembly
	24025923	Pressure Fitting
	29025300	Assembly Screw
	29025400	Retaining Screw
	29025507	Exhaust Adapter

Specifications are subject to alteration for improvement without notice.

CARBURETOR EXPLODED VIEW & PARTS LIST

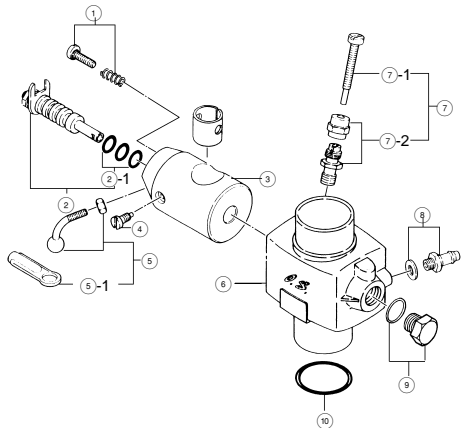

No.	Code No.	Description
①	26881603	Mixture Control Screw
②	29081305	Mixture Control Valve Assembly
②-1	24881824	"O" Ring
③	29081200	Carburettor Rotor
④	26881311	Mixture Control Valve Set-screw
⑤	26881406	Throttle Lever Assembly
⑤-1	26881424	Universal Rink
⑥	29081110	Carburettor Body
⑦	27181600	Throttle Stop Screw Assembly
⑦-1	27181620	Throttle Stop Screw
⑦-2	27181610	Throttle Stop Screw Holder
⑧	22681953	Fuel Inlet
⑨	22881300	Plug Screw
⑩	29015019	Carburettor Rubber Gasket

Specifications are subject to alteration for improvement without notice.

THREE VIEW DRAWING

Dimensions(mm)

SPECIFICATIONS

■ Displacement	17.83 cc (1.088 cu.in.)
■ Bore	29.0mm (1.142 in.)
■ Stroke	27.0mm (1.063 in.)
■ Practical R.P.M.	2,000~16,000 r.p.m.
■ Power output	3.0 bhp / 16,000 r.p.m.
■ Weight	750g(26.5oz.)

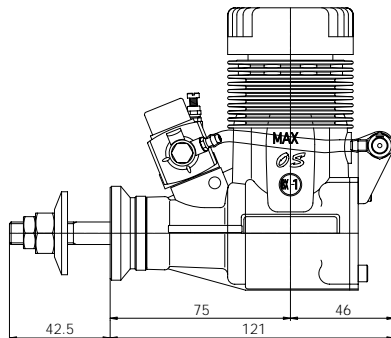
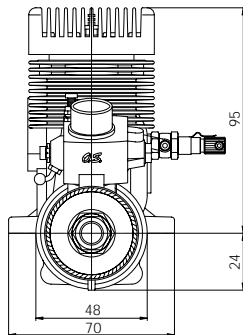
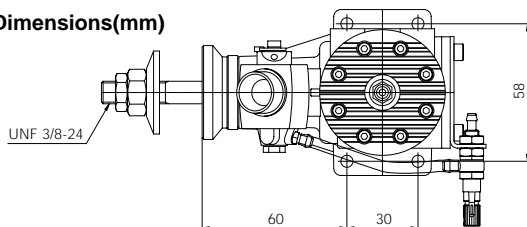

O.S. GENUINE PARTS & ACCESSORIES

■ O.S. GLOW PLUGS



No.8
(71608001)

A5
(71605100)

■ RADIAL MOTOR MOUNT

(71907000)

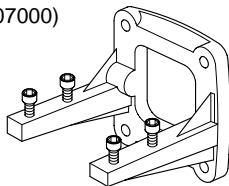

■ PROPELLER LOCKNUT SET FOR TRUTURN SPINNER

(29310110)



■ BOOSTER TERMINAL KIT

(72200130)



■ LOCK WASHER

M5 (10Sets)
(55500004)



■ SUPER FILTER

(72403050)



■ NON-BUBBLE WEIGHT

(71531000)



■ LONG SOCKET WRENCH WITH PLUG GRIP

(71521000)

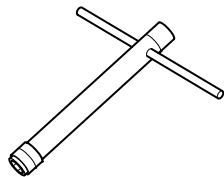



O.S. ENGINES MFG.CO.,LTD.

6-15 3-Chome Imagawa Higashisumiyoshi-ku
Osaka 546-0003, Japan TEL. (06) 6702-0225

FAX. (06) 6704-2722

URL : <http://www.os-engines.co.jp>

© Copyright 2001 by O.S.Engines Mfg. Co., Ltd. All rights reserved. Printed in Japan.

110100