

O.S. ENGINE

Injection Power

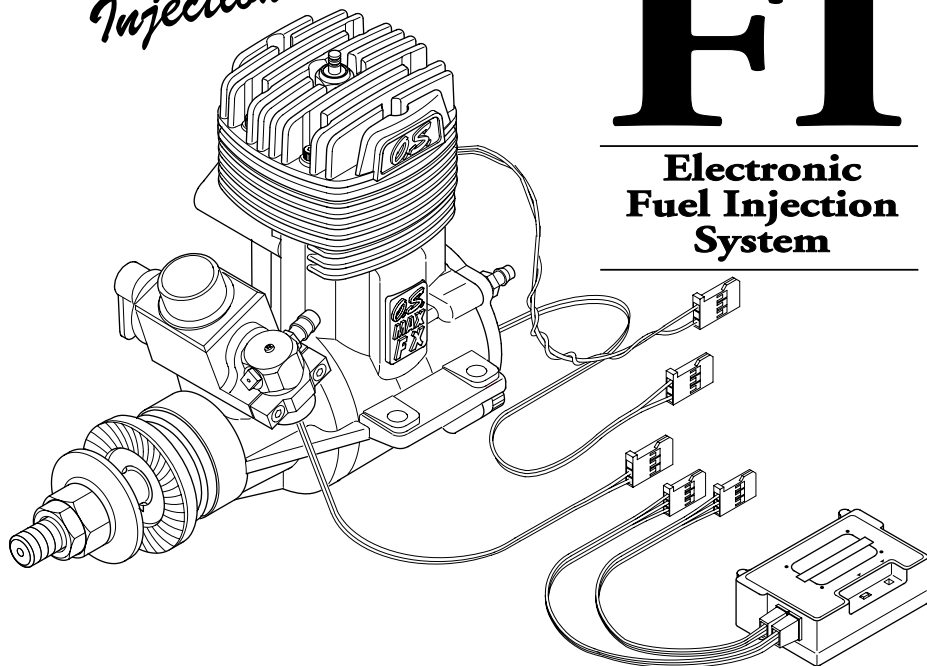

MAX 160FX FI

**Electronic
Fuel Injection
System**

OWNER'S INSTRUCTION MANUAL

It is of vital importance, before attempting to operate your engine, to read the general '**SAFETY INSTRUCTIONS AND WARNINGS**' section on pages 2-4 of this booklet and to strictly adhere to the advice contained therein.

- Also, please study the entire contents of this instruction manual, so as to familiarize yourself with the controls and other features of the engine.
- Keep these instructions in a safe place so that you may readily refer to them whenever necessary.
- It is suggested that any instructions supplied with the aircraft, radio control equipment, etc., are accessible for checking at the same time.

CONTENTS

SAFETY INSTRUCTIONS AND WARNINGS ABOUT YOUR O.S. ENGINE	2-4
INTRODUCTION, FEATURES	5
BASIC ENGINE PARTS	6
CONNECTING WITH THE EC-2 (LED Display, Buzzer notes and status)	7-8
LIST OF 160FX-FI USAGE CONDITIONS	9
BEFORE INSTALLING THE ENGINE	10
INSTALLATION PROCEDURE	10-12
LINKAGE AND INITIAL SETTINGS	13-14
ENGINE STARTING AND AIR-FUEL MIXTURE ADJUSTMENT	14
ENGINE STARTING	15-16
FLIGHT ADJUSTMENT	17
GLOW PLUG, CARE AFTER USE	18
TROUBLESHOOTING	19
ENGINE & INJECTOR AIR VALVE EXPLODED VIEW	20
PARTS LIST	21
THREE VIEW DRAWING	22
O.S. GENUINE PARTS & ACCESSORIES	23
MEMO	24

SAFETY INSTRUCTIONS AND WARNINGS ABOUT YOUR O.S. ENGINE





Remember that your engine is not a " toy ", but a highly efficient internal-combustion machine whose power is capable of harming you, or others, if it is misused or abused. As owner, you, alone, are responsible for the safe operation of your engine, so act with discretion and care at all times.

If at some future date, your O.S. engine is acquired by another person, we would respectfully request that these instructions are also passed on to its new owner.

■ The advice which follows is grouped under two headings according to the degree of damage or danger which might arise through misuse or neglect.

 WARNINGS	These cover events which might involve serious (in extreme circumstances, even fatal) injury.
--	--

 NOTES	These cover the many other possibilities, generally less obvious sources of danger, but which, under certain circumstances, may also cause damage or injury.
---	--

 WARNINGS	
<ul style="list-style-type: none">• Never touch, or allow any object to come into contact with, the rotating propeller and do not crouch over the engine when it is running.	
<ul style="list-style-type: none">• A weakened or loose propeller may disintegrate or be thrown off and, since propeller tip speeds with powerful engines may exceed 600 feet(180 metres) per second, it will be understood that such a failure could result in serious injury, (see 'NOTES' section relating to propeller safety).	
<ul style="list-style-type: none">• Model engine fuel is poisonous. Do not allow it to come into contact with the eyes or mouth. Always store it in a clearly marked container and out of the reach of children.	
<ul style="list-style-type: none">• Model engine fuel is also highly flammable. Keep it away from open flame, excessive heat, sources of sparks, or anything else which might ignite it. Do not smoke or allow anyone else to smoke, near to it.	
<ul style="list-style-type: none">• Never operate your engine in an enclosed space. Model engines, like automobile engines, exhaust deadly carbon-monoxide. Run your engine only in an open area.	
<ul style="list-style-type: none">• Model engines generate considerable heat. Do not touch any part of your engine until it has cooled. Contact with the muffler(silencer), cylinder head or exhaust header pipe, in particular, may result in a serious burn.	



NOTES

- This engine was designed for model aircraft. Do not attempt to use it for any other purpose.
- Mount the engine in your model securely, following the manufacturers' recommendations, using appropriate screws and locknuts.
- Be sure to use the silencer (muffler) supplied with the engine. Frequent exposure to an open exhaust may eventually impair your hearing. Such noise is also likely to cause annoyance to others over a wide area.
- Install a top-quality propeller of the diameter and pitch specified for the engine and aircraft. Locate the propeller on the shaft so that the curved face of the blades faces forward-i.e. in the direction of flight. Firmly tighten the propeller nut, using the correct size wrench.
- Always check the tightness of the propeller nut and retighten it, if necessary, before restarting the engine, particularly in the case of four-stroke-cycle engines. A safety locknut assembly is provided. Always use it. This will prevent the propeller from flying off in the event of a "backfire", even if it loosens.
- If you install a spinner, make sure that it is a precision made product and that the slots for the propeller blades do not cut into the blade roots and weaken them.
- Discard any propeller which has become split, cracked, nicked or otherwise rendered unsafe. Never attempt to repair such a propeller: destroy it. Do not modify a propeller in any way, unless you are highly experienced in tuning propellers for specialized competition work such as pylon-racing.
- Use an electric starter for this engine. The wearing of safety glasses is also strongly recommended.
- Take care that the glow plug clip or battery leads do not come into contact with the propeller. Also check the linkage to the throttle arm. A disconnected linkage could also foul the propeller.



NOTES

- Adjust the throttle linkage so that the engine stops when the throttle stick and trim lever on the transmitter are fully retarded. Alternatively, the engine may be stopped by cutting off the fuel supply. Never try to stop the engine physically.
- Take care that loose clothing (ties, shirt sleeves, scarves, etc.) do not come into contact with the propeller.
Do not carry loose objects (such as pencils, screwdrivers, etc.) in a shirt pocket from where they could fall through the propeller arc.
- Do not start your engine in an area containing loose gravel or sand.
The propeller may throw such material in your face and eyes and cause injury.
- For their safety, keep all onlookers (especially small children) well back (at least 20 feet or 6 meters) when preparing your model for flight. If you have to carry the model to the take-off point with the engine running, be especially cautious. Keep the propeller pointed away from you and walk well clear of spectators.
- **Warning!** Immediately after a glowplug-ignition engine has been run and is still warm, conditions sometimes exist whereby it is just possible for the engine to abruptly restart if the propeller is casually flipped over compression **WITHOUT** the glowplug battery being reconnected. Remember this if you wish to avoid the risk of a painfully rapped knuckle!

INTRODUCTION

This engine is the MAX-160FX-FI (fuel injection) engine equipped with a revolutionary fuel supply system that was jointly developed by Futaba, a manufacturer of Radio control equipment, and O.S. Engines, a manufacturer of model engines.

This system detects engine speed with a sensor based on throttle signals transmitted from a transmitter. It then determines the fuel injection volume based on the required amount of fuel to be supplied for that engine speed as calculated by an electronic control unit referred to as the "EC-2", after which fuel is injected into the engine from an injector. In addition, adjustments can also be made using dial on the transmitter. The result is an engine for Aerobatic and big scale models that features excellent engine speed linearity relative to throttle operation under all types of flight conditions.

FEATURES

Supplies the Proper Amount of Fuel at all Times

- Easier starting
- Greater stability during idling
- Excellent linearity and response relative to stick operation.

Simple Adjustment Using Dials on the Transmitter

- Air-fuel mixture at medium and high speeds can be safely and easily adjusted from the transmitter.
- Adjustments can be made while on the ground and during flight.

Stable Supply of Fuel at all Times

Pressurized fuel is controlled at a constant pressure with respect to all types of movement during flight allowing stable engine performance at all times.

Light Weight and Easy Installation

The sensor and injector mounted on the engine are both compact and lightweight, while the electronic control unit (EC-2) is also lightweight, enabling various connections to be made easily the same as plugging in a servo.

BASIC ENGINE PARTS

Accessories

- EC-2 Assembly
 - Y harness
 - Duble-sided sponge-backed cushioning tape
- Check Valve
- Fuel Filter
- Driver to push Limit Setting Switch
- Glow plug No.8
- E-5010 Silencer

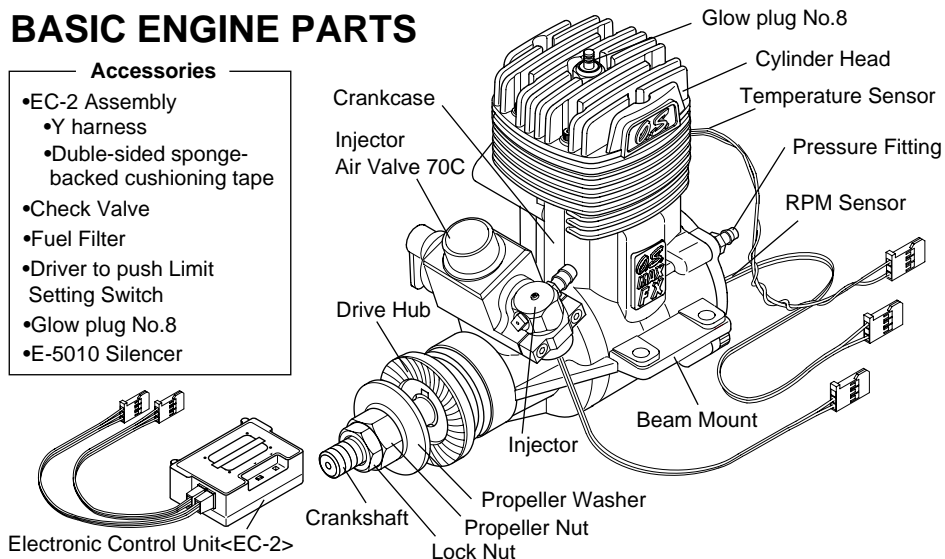

INSTALLATION OF THE AIR VALVE

As delivered, the engine has its air valve lightly installed into the intake boss. Secure it as follows.

1. Loosen the retainer nut, rotate the air valve to its correct position and make sure that it is pressed well down into the intake boss, compressing the rubber gasket, before retightening nut.
2. Rotate the retainer nut gently until it stops, then tighten a further 90-120°. Do not overtighten the screw as this will damage the thermo insulator.

Injector

*** Never attempt to disassemble the injector. It may not be able to be reassembled.**

The injector consists of a solenoid valve with built-in regulator. It controls pressurized fuel at a constant pressure and accurately injects fuel based on signals from the electronic control unit (EC-2).

Temperature Sensor

This measures the temperature of the engine exhaust unit.

RPM Sensor

The RPM sensor is provided with a power generating sensor. When the crankshaft passes in front of the sensor, the signal that is generated is transmitted to the electronic control unit (EC-2). Engine speed is then calculated based on that signal which is then used to determine the timing at which fuel is injected.

Electronic Control Unit<EC-2>

(abbreviated as simply EC-2)

The EC-2 transmits fuel injection signals to the injector to ensure the proper amount of fuel injection based on basic fuel injection data that has been previously entered and constantly changes with position of throttle stick.

Check Valve

This one-way valve's function is to pressurize the fuel tank by crankcase pressure and prevent fuel from returning to the engine crankcase.

Fuel Filter

This fine mesh filter prevents foreign matter from the fuel tank from plugging the small injector valve.

Y harness

This cord is used to connect the receiver (throttle channel), throttle servo and EC-2.

CONNECTING WITH THE EC-2

Connect the receiver and servo-related components (rudder section) in the same manner as in the past.

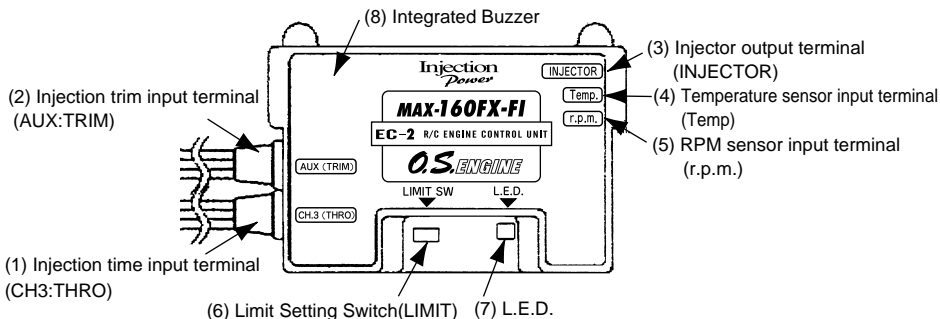

Two extension cords (sold separately) of a length corresponding to the airframe are required for connecting (1) and (2).

(1) Injection Time Input Terminal<Black> (CH3:THRO)

Connect the y harness provided with the CH3 THRO input terminal to throttle channel of the receiver (throttle: CH3), connect the wiring connector from the throttle servo to one of the double-opening connectors on the opposite side, and connect the other double-opening connector to CH3:THRO of EC-2. (Use the separately sold extension cord if the wiring cords are too short.)

(2) Injection Trim Input Terminal<Red> (AUX:TRIM)

Connect a spare channel for dial use of the receiver (e.g. channel 7) to the AUX:TRIM terminal. (Use the separately sold extension cord if the wiring cords are too short.)

(3) Injector Output Terminal

Connect the injector connector to the injector output terminal. Protect the lead wire with a heat-resistant tube, etc. if it makes contact with the engine mount.

(4) Temperature Sensor Input Terminal

Connect the temperature sensor connector to the temperature sensor input terminal.

(5) Rotation Sensor Input Terminal Connect the rotation sensor connector to the rpm input terminal.

(6) Limit Setting Switch(LIMIT) Push with driver supplied when setting limit.

(7) L.E.D.(Display of green and red)

It flashes or changes color when setting and checking limit, and adjusting injection trim. It flashes with the color of the injection trim when the engine is running.

LED Display

	Transmitter Operation	LED Status
When the engine is not running	Turn the dial right to reduce injection volume.	Red lights
	Turn the dial left to increase injection volume.	Green lights
	Limit position	Flashes (color depends on the dial position)
When the engine is running	Turn the dial right to reduce injection volume.	Red flashes
	Turn the dial left to increase injection volume.	Green flashes

*Turning direction of dial shows the standard setting direction.

*Dial position shows plus (green - rich) or minus (red - lean) from the zero position (basis injection volume.)

(8) Integrated Buzzer Buzzer sounds when setting Limit, dial is set neutral a error happens.

Buzzer notes and status

Notes	Status
Nil	Normal
One note (Pi)	Limit at Low is set
Two successive notes (PiPi)	Dial neutral Limit at High is set
*Repeated one note (Pi...Pi...)	Temperature Sensor is disconnected
*Repeated two successive notes (PiPi...PiPi...)	Error on setting Limit
*Repeated three successive notes (PiPiPi...PiPiPi...)	Battery voltage falls down (below 3.8v)

*mark shows alarm for error.

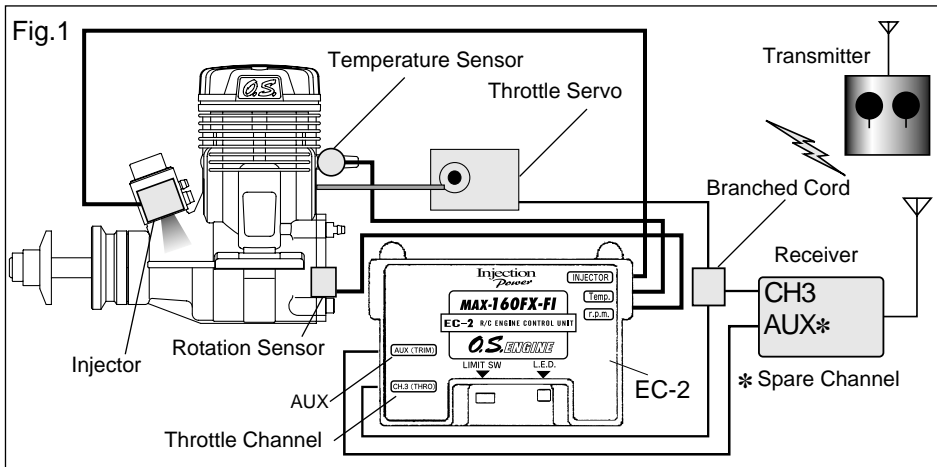

Injection trim adjustment

corresponds to needle-valve adjustment of conventional carburetor)

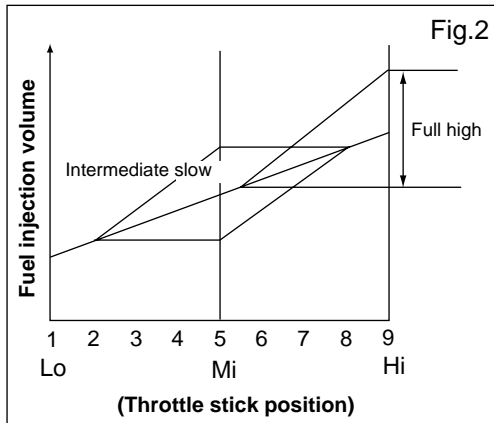

Injection trim can be adjusted independently for two area as shown in the graph. Intermediate slow and full high are adjusted with the injection trim adjustment dial (spare channel dial) on the transmitter.

LIST OF 160FX-FI USAGE CONDITIONS

Part	Manufacturer	Name	Remarks
Silencer	O.S.	*E-5010	
Glow plug	O.S.	*No.8	
Propeller	Commercially available high-quality product	General references: * 17x12 (Basic propeller) 16x12-14 16.5x12-13 17x10-13 18x8-10	Maximun speed should be between 7,300 and 8,500 rpm.
Fuel	Commercially available high-quality product	10-25% nitromethane 15-20% oil	Adjustment may vary slightly according to the amounts of nitromethane and oil. Use a fuel containing as low nitromethane as possible within the percentage shown left. Too much oil may cause malfunction.
Transmitter	FUTABA FUTABA JR JR JR	*1024ZA T9Z FF8A PCM10S PCM10X X3810	Spare channel dial (used at 100% by canceling mixing and expo, etc. when used alone. In case of FUTABA, set with spare channel NORM direcion. In case of other marks, it is necessary to change setting it the direction is reverse.
	SANWA	STYLUS	Only Z connectors can be used (check whether polarity matches).
Aircraft		Sport, Big Scale, Aerobatic	Wingspan 1.7-2.0m Weight 4.7-5.8kg

The contents of the user's manual are based on those products indicated with an asterisk (*).

BEFORE INSTALLING THE ENGINE

In addition to the general tools, the following tools are convenient to use.

- 14-17mm open end wrench
- Large capacity electric starter and battery
- Hex wrench to secure the silencer (supplied with the engine)

INSTALLING THE GLOW PLUG

Carefully insert plug, with washer, fingertight only, before final tightening with the correct size plug wrench.

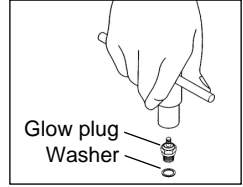

INSTALLATION PROCEDURE

NOTE:

Be sure to secure large enough air intake and outlet area for cooling the engine in order not to overheat the engine.

Install the 160FX-FI while taking the following matters into consideration.

(1) MAX-160FX-FI Engine

The following components are required during installation: EC-2, y harness, check valve, fuel filter, E-5010 silencer, extension cord (sold separately), double-sided, sponge-backed cushioning tape.

(2) Engine Mount

Installation in the model

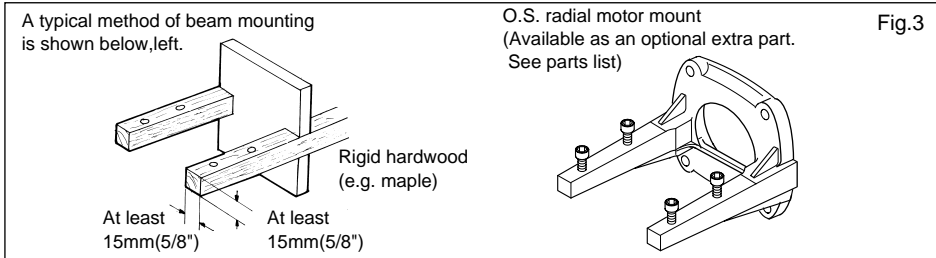

Make sure that the mounting beams are parallel and that their top surfaces are in the same plane.

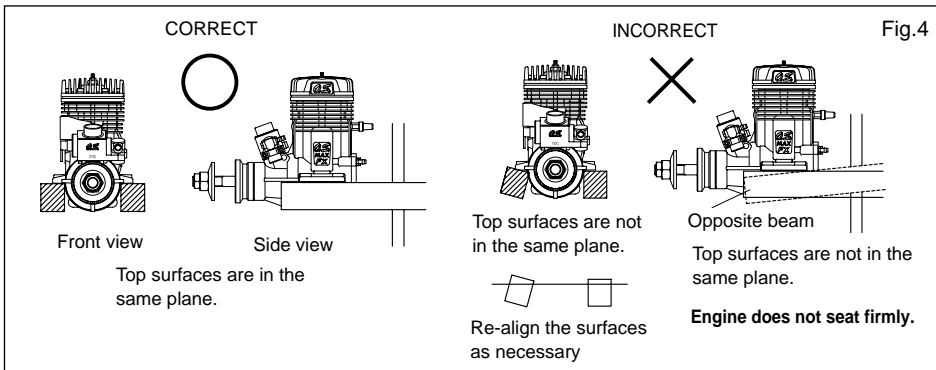

How to fasten the mounting screws.

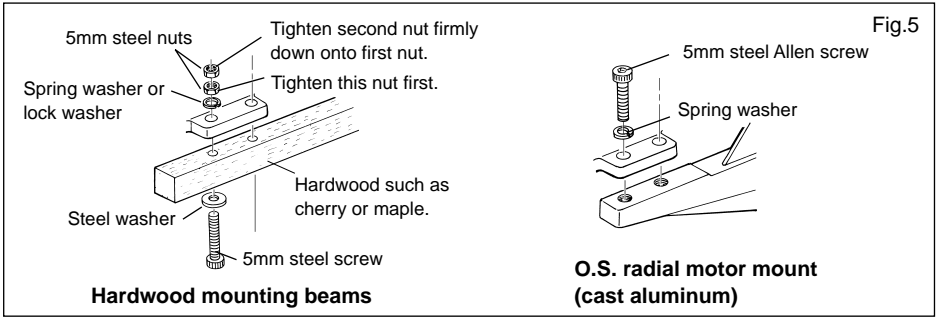

A soft engine mount is recommended but should be made of firm enough material to prevent excessive engine movement but still minimize engine vibration. If engine vibration is excessive the opening angle of the air valve may vary causing unstable engine operation and possible stalling. In addition, adequate clearance must be provided to ensure there is no contact between the injector, temperature sensor and rotation sensor with the airframe.

(3) Fuel Tank and Lines

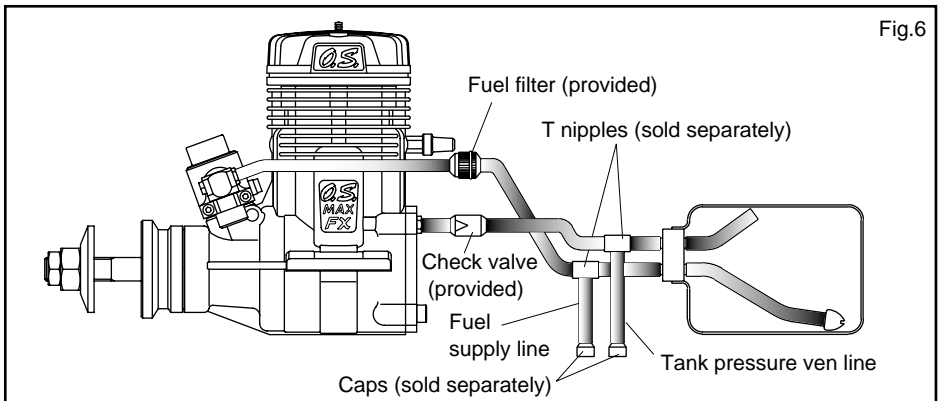

Connect all lines securely as shown in the figure above. Since high pressure is applied to the fuel tank from the engine crankcase, make connections using a commercially available, thick-walled silicon tube. In addition, make sure to securely seal the area around the cap. If the outlet of the T nipples is left accessible from outside the airplane, it will make venting tank pressure and refueling easier. Always make sure to use the check valve and fuel filter provided.

- Make connections in the following order: Engine (carburetor nipple), check valve (provided), T nipple and fuel tank (air chamber side)
- Make connections in the following order: Injector, fuel tank (provided), T nipple and fuel tank (weighted side)

NOTE:

Always make sure to release any pressure remaining in the tank when adding fuel and following engine operation.

Silicon tubing is easily damaged by sharp objects that can lead to the formation of holes and cracks. Check the surrounding area of the presence of potentially harmful sharp objects.

(4) EC-2

Install the EC-2 in a location that is not susceptible to the effects of heat, fuel or vibrations while allowing easy manipulation. Always make sure to attach double-sided, sponge-backed cushioning tape or Velcro tape between the airframe and EC-2 as measures against vibrations.

(5) INSTALLATION OF SILENCER (MUFFLER)

To fit the standard silencer

1. Fix the exhaust adaptor plate to the engine with the two M5 x15 Allen screws supplied.
2. Now fit the silencer to the exhaust adaptor with M5x20 Allen screws, also provided.

NOTE:

In order to prevent the leakage of exhaust oil from between the engine and adaptor, and between the adaptor and silencer, apply a suitable silicone sealant to the joint faces during assembly.

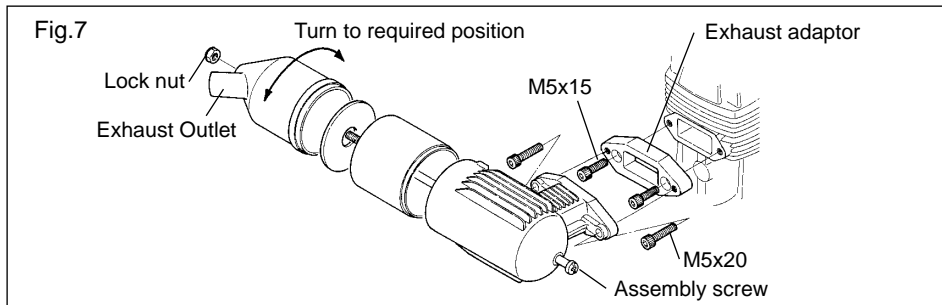

The angled exhaust outlet is adjustable and can be rotated to any desired position in the following manner.

1. Loosen locknut and assembly screw.
2. Set the exhaust outlet at the required angle by rotating the rear part of the silencer.
3. Re-tighten the assembly screw, followed by the locknut.

(6) PROPELLER & SPINNER ATTACHMENT

There is a risk, particularly with powerful four-stroke engines, of the propeller flying off if the prop nut loosens due to detonation ("knocking") in the combustion chamber when the engine is operated too lean, or under an excessively heavy load.

Obviously, this can be very hazardous. To eliminate such dangers, the O.S. Safety Locknut Assembly was devised.

Fit this as follows:

1. Ream the propeller shaft hole to 9.6mm bore with an appropriate reamer, checking that the hole is exactly centered.
2. Fit the prop to the engine shaft, followed by the retaining washer and prop nut and tighten firmly with a 17mm wrench.
3. Add the special tapered and slotted locknut and secure with a 14mm wrench while holding the prop nut with the 17mm wrench.

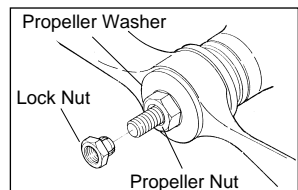

Since the engine is intended to be started with an electric starter, the addition of a spinner assembly for centering the starter sleeve is desirable. Special propeller locknut set (Code No. 29310110) is available as optional extra for use with spinners.

LINKAGE AND INITIAL SETTINGS

Ensuring a proper linkage is important in the 160RX FI system in terms of a proper air-fuel mixture. In other words, it is necessary to maintain the proper relationship between opening of the air valve (stick position) and fuel injection by the injector.

Call up the ATV menu on the condition menu and select THR. Confirm that it is in the center of the throttle curve when the stick is in the center position.

Then align the mark in the center of the air valve at that point.

The center of the curve is the center, and if the stick is shifted out of position, give priority to the center of the throttle curve.

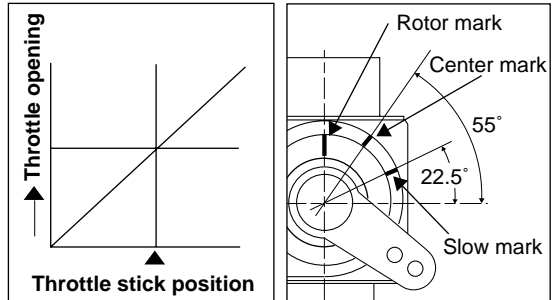

Make the settings according to the procedures described below.

(1) Transmitter Trim Adjustment

Adjust the throttle trim on the transmitter to 0.

(2) Confirmation of Amount of Throttle Angle

Set the angle adjustment of all throttle channels (ATV AFR) to 100% and sub trim to 0.

Set mixing of the throttle curve, expo channel and so forth to off (0), and set the throttle trim in the center.

(3) Throttle Servo and Air Valve Linkage Method

Align the throttle stick on the transmitter at the center position as shown in the figure. Accurately align the throttle servo and air valve sections as shown in the figure.

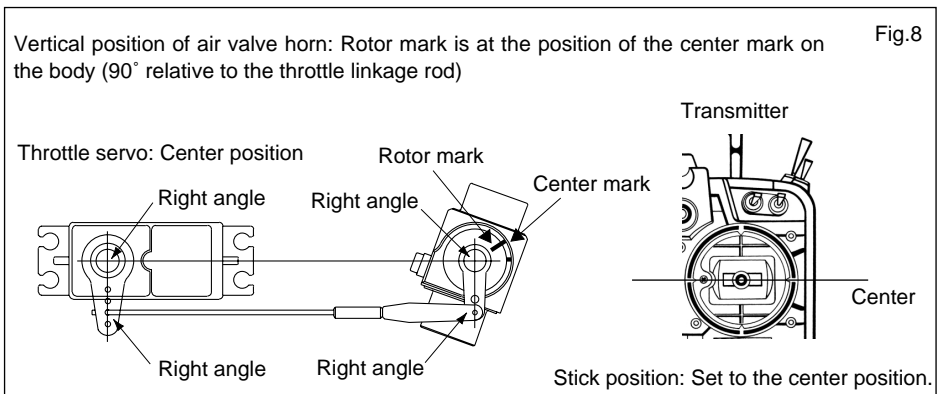

(4) Adjustment of Amount of Throttle Servo and Air Valve Angle

Move the throttle stick on the transmitter to slow and then full high. If there is excessive or insufficient opening of the air valve, adjust the opening with the throttle angle adjustment function (ATV). Confirm that the servo is not subjected to an excessive load due to tugging or pulling. An excessive load on the servo can cause the battery to discharge and air valve to lock.

(5) Engine Cutoff Adjustment

When using a transmitter equipped with an engine cutoff function, switch the transmitter to the engine cutoff position and adjust the air valve so that it is fully closed at that time. Confirm that the servo is not subjected to an excessive load due to pulling.

(6) Confirmation of Throttle and Air Valve Operation

When the stick is in the slow position: The rotor mark should be located at the slow mark of the body. When the stick is in the center position: The rotor mark should be located at the center position of the body. When the stick is in the full high position: The air valve should be fully open. Recheck these positions.

(7) Lmt Setting

The movemnt of engine control has considerable significance with respect to the injection operation. Since there may be errors in operation depending on the direction and movement, always make sure to perform the Lmt setting when the engine is not running.

- Switch on the transmitter then the receiver.
- Move the throttle stick on the transmitter to the full slow position and push the Limit setting switch to set Low Limit. At this time Buzzer sounds one note "Pi" and LED flashes green.
- Then, move the throttle stick to the full high position and push the Limit setting switch to set High Limit. At this time Buzzer sounds two successive notes "PiPi" and LED flashes red. If the setting is failed, Buzzer sounds repeated twosuccessive notes "PiPi...PiPi..." and LED flashes red. In this case, start again with Low Limit setting.

*Memory contents remain intact even if the power is turned off.

*Repeat steps①through⑦when the throttle linkage has been changed.

ENGINE STARTING AND AIR-FUEL MIXTURE ADJUSTMENT

- (1) Switch on the transmitter then the receiver.
- (2) Make sure the Limit is set. Make sure that LED flashes when the throttle stick is at the full slowposition as well as at the tull high position. Flashing color is the color at the injection trim set position.
- (3) Confirm that the rotor mark on the air valve is located at the center mark on the air valve body when the throttle stick on the transmitter is in the center position.
(When the settings of (2) and (3) are unable to be made, repeat linkage of the throttle servo and air valve as well as the Limit settings.)
- (4) Make sure that injection trim functions correctly when the throttle stick is at full high position as well as at the center position. First make sure that LED lights red when the dial is turned right and LED lights green when the dial is turned loft, with the throttle stick at full high position. (In case of other maks, if the direction is reverse, it is necessary to reverse the setting. Even if the direction is reverse, there is no functional problem.) Then set the dial at the position where the Buzzer sounds two successive notes (PiPi) turning the dial right and left. Then, more the throttle stick to the full slow position and set the dial at 0 position. Now the 0 setting at full high position is completed. Then, carry out the same procedure with the throttle stick at the center position.

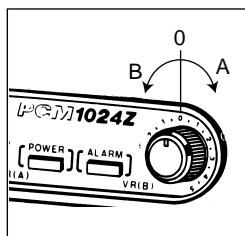

***This adjustment function employs the incremental system. Therefore, it is normal if the injection trim dial 0 position changes during operation. Repeat the above procedures if 0 setting is required. LED color does not show engine adjustment condition.**

Note:

This injection system was developed for use in model airplanes. All adjustments are not performed automatically. Always make sure to check the contents of adjustments prior to use.

ENGINE STARTING (RPM shown are with the standard setting.)

***Basic setting It is suggested to start with this setting.**

General reference for engine speed	Case of a 17 x 12, 2-blade propeller
Full slow engine speed	1,700~1,800r.p.m.
Intermediate slow engine speed	6,100~6,300r.p.m.
Full high engine speed	7,500~7,800r.p.m.

Fuel	10~15% nitromethane 15~20% oil
Silencer	E-5010

Note:

The engine speed will not be the same depending on propeller variations, engine mounting method, linkage method between the throttle servo and air valve, and differences in the fuel used.

If the engine speed is quite different from those shown above, it may mean that the setting for the throttle servo and air valve linkage is incorrect or the fuel injection trim volume has changed considerably. Check these items by returning to the procedure for readjustment.

Note:

- When engine speed is abnormally high, always make sure to stop the engine and inspect the problem since this can cause damage to the engine.
- In cases when there are considerable temperature changes during the course of a day such as in the spring and autumn, the fuel injection volume may not be able to keep with engine performance to a certain extent. If this happens, readjust the injection trim adjustment dial (spare channel dial) before further use.

*This engine employs pressurized fuel feed system, applying high pressure to the fuel tank from the crankcase. When starting first time or starting after long, storage or starting in winter when the temperature is less than 10°C, it makes a start easy to apply an electric starter for about 5 to 10 seconds without connecting the plug battery.

- (1) Always be sure to close the throttle stick to idle position before applying the starter and starting battery. (Do not attempt to start the engine manually since this is potentially dangerous.) After the engine has started, gradually move the throttle stick on the transmitter to the full high position. Then gradually move the throttle stick to the full slow position and disconnect the starting battery. Again move the throttle stick to the full high position and check the engine speed.

NOTE: Avoid moving throttle stick to higher than intermediate slow position, after injection trim adjustment is completed.

Adjust the injection trim volume with the injection trim adjustment dial (spare channel dial) so that engine speed stabilizes at around 7,500-7,800 rpm (this may vary slightly depending on the propeller used). If LED lights green, mixture can be adjusted richer, and if LED lights red, mixture can be adjusted leaner. The contents of the adjustment are instantaneously stored in memory. Move the stick to the slow position. At this time, return the injection trim adjustment dial (spare channel dial) to the center (0) position.

- (2) Put the throttle stick in the center position. After a short time (5-10 seconds), check the engine speed. Adjust the injection trim volume with the injection trim adjustment dial (spare channel dial) so that engine speed stabilizes in the vicinity of 6,100-6,300 rpm (this may vary depending on the propeller used). The contents of the adjustment are instantaneously stored in memory.
- (3) Put the throttle stick in the full slow position. Return the injection trim adjustment dial (spare channel dial) to the center (0) position. Adjust the throttle trim so that engine speed at full slow stabilizes in the vicinity of 1,800 rpm.
- (4) Reconfirm whether engine speed reliably responds to throttle operation at all speeds, and whether the throttle stick responds from slow operation to quick operation. Adjustments are satisfactory if engine speed remains stable.

Note:

Injection trim adjustment uses the same adjustment dial for both intermediate slow and high. (The use of an incremental system allows the same dial to be used for both.) If adjustment is still not adequate when the dial is turned all the way to the right or left during adjustment, temporarily move the throttle stick to the full slow position and move the dial to the center (0) position. This also allows adjustment of the air-fuel mixture. The injection trim volume at intermediate slow and full high do not change even if the adjustment trim dial is moved with the throttle stick in the full slow position.

In the case of a new engine, start adjustment of injection trim volume on the rich side (LED lights green) and then readjust after making 3 or 5 flights.

FLIGHT ADJUSTMENT

The next step is to take the airplane on an actual flight. Although the adjustments have been already made, recheck the Limit setting.

Put the throttle stick in the slow position and after starting the engine and allowing it to warm up, check the stability of engine speed in the slow position (by confirming that the engine does not stall) and try flying the airplane.

After taking off, fly level for several minutes. Next, repeat flying level in a straight line at full speed. (This is one way to check the difference in engine speeds when on the ground and in flight.) If it appears that engine speed fluctuates while flying straight, this indicates that excessive fuel is being supplied to the engine. Turn the injection trim adjustment dial (spare channel dial) in the (-) lean direction (right) by about 10° (about 2 clicks) with the throttle stick in the full high position. Then repeat flying straight in the same manner as before. Repeat this adjustment procedure until engine speed has stabilized. (The engine speed will not change immediately after the air-fuel mixture has been changed. Fly the airplane straight several times to confirm that engine speed has become stable.) When flying straight as described above, fly both into the wind and with the wind. Adjustment is completed when there are no disturbances in engine speed when flying level.

If the engine produces a higher pitch sound immediately after taking off or if the engine appears to lose power and exhaust cannot be seen at all (although varying somewhat depending on the fuel), turn the injection trim adjustment dial (spare channel dial) in the (+) rich direction (left) by about 45° with the throttle stick in the full high position and reconfirm engine operation by continuing to fly for 3-4 minutes. (When this is difficult to evaluate, land the airplane and recheck engine speed with the throttle stick in the center and full high positions.) When there is still no change even when the above adjustment has been made, land the airplane and try readjusting from the first step of the adjustment procedure. This completes the adjustment procedure.

NOTE:

- Repeat this procedure when changing propeller or fuel.
- Torgne Roll manœuvre increases engine temperature. Cool the engine with level flight.

GLOWPLUGS

Since the compatibility of glowplug and fuel may have a marked effect on performance and reliability, it may be worthwhile to choose the R/C type plug found most suitable after tests. O.S. No.8 plug is supplied with the engine. Recommended O.S. plug are No.8 and Type F is suitable to use for richer mixture. Carefully install plug finger-tight, before final tightening with the correct size plug wrench.

The role of the glowplug

With a glowplug engine, ignition is initiated by the application of a 1.5-volt power source. When the battery is disconnected, the heat retained within the combustion chamber remains sufficient to keep the plug filament glowing, thereby continuing to keep the engine running. Ignition timing is 'automatic' : under reduced load, allowing higher rpm, the plug becomes hotter and, appropriately, fires the fuel/air charge earlier; conversely, at reduced rpm, the plug become cooler and ignition is retarded.

Glowplug life

Particularly in the case of very high performance engines, glowplugs must be regarded as expendable items.

However, plug life can be extended and engine performance maintained by careful use, i.e.:

- Install a plug suitable for the engine.
- Use fuel containing a moderate percentage of nitromethane unless more is essential for racing events.
- Do not run the engine too lean and do not leave the battery connected while adjusting the needle.

When to replace the glowplug

Apart from when actually burned out, a plug may need to be replaced because it no longer delivers its best performance, such as when:

- Filament surface has roughened and turned white.
- Filament coil has become distorted.
- Foreign matter has adhered to filament or plug body has corroded.
- Engine tends to cut out when idling.
- Starting qualities deteriorate.

CARE AFTER USE

- First vent the pressure from the fuel tank. Next, drain any fuel in the fuel tank. Turn on the transmitter and receiver switches but do not heat the plug. Move the transmitter engine control lever to the center position without heating the plug, and then turn the engine over with the electric starter several times. (This is done to discharge any fuel between the tank and the injector.) Pour a little after-run oil in the air valve and turn over the engine with the starter several times.
- In order to maintain the engine in the optimum state, it is important to vent any residual gas generated during engine operation as quickly as possible. In addition, since this engine uses a manifold and tuned silencer, residual gas may be present in these components as well. It is recommended to remove the tuned silencer after use and store it.
- Connectors and leads are arranged in the engine compartment. They be soiled with dust or other debris. (This can cause a malfunction.) Clean these components to prevent them from becoming soiled as much as possible. Do not use paint thinner, gasoline or other cleaners that erode plastic when cleaning.

TROUBLESHOOTING

Problem	Confirmation
Engine does not start	<ul style="list-style-type: none"> • Is the power turned on? • Are the connectors securely connected? • Is the lead wire broken? • Is the plug burned out? • Has Limit been set? • Are the connections correct? • Recheck the Buzzer sounds and LED display.?
Engine operation is unstable at low speeds	<ul style="list-style-type: none"> • Are the rubber dampers of the engine soft mount too soft? • Are the rubber dampers of the soft mount damaged? • Is the throttle linkage sticking? • Is the linkage too weak causing it to be affected by vibrations? • Is the check valve normal (Is the fuel tank pressurized?) • Is the servo malfunctioning or is the servo mount loose?
Engine operation is unstable at high speeds	<ul style="list-style-type: none"> • Is the propeller size correct? • Is the engine running at 8,500 rpm or higher? • Is there an abnormality in the engine soft mount (cracked)? • When there are occasional disturbances in engine speed when the air-fuel mixture is rich at high speeds, there may be a problem with the temperature sensor. Is an abnormal temperature (300°C or higher) displayed for Tmax Tmp? • Is the filter clogged?
Engine stalls	<ul style="list-style-type: none"> • Are the rubber dampers of the engine soft mount too soft? • Are the rubber dampers of the soft mount damaged? • Has the plug deteriorated? • Is there any sticking or abnormalities in the linkage? • Is the oil content of the fuel correct (not too much)? • Is the idling speed too low? • Is the check valve functioning properly? • Is the air control servo operating abnormally (hunting)? • If the sound of the engine remains unchanged when diving during flight and stick response is lost, this indicates that there is too much fuel being supplied to the engine. Try adjusting intermediate slow trim in the (-) direction (right). • Is the air control linkage too weak so that the operation of the air valve either stops or is delayed relative to the operation of the servo? (Try using a thicker component for the linkage.) • Is the carburetor secured? (Check the carburetor retainer.)

ENGINE PARTS LIST

No.	Code No.	Description
①	2 9604 000	Cylinder Head
②	2 9603 100	Cylinder Liner
③	2 9603 400	Piston Ring
④	2 9603 200	Piston
⑤	2 9606 000	Piston Pin
⑥	2 8117 000	Piston Pin Retainer
⑦	2 9405 000	Connecting Rod
⑧	2 9483 010	Injector Air Valve Set (70c)
⑨	2 9610 100	Lock Nut Set
⑩	2 9608 000	Drive Hub
⑩-1	4 5508 200	Woodruf Key
⑪	2 9320 000	Thrust Washer
⑫	4 6231 000	Crankshaft Ball Bearing(Front)
⑬	2 9601 010	Crankcase
⑭	2 9081 719	Carburettor Retainer
⑮	2 9401 200	Temperature Sensor Set
⑯	2 9630 000	Crankshaft Ball Bearing(Rear)
⑰	2 9602 000	Crankshaft
⑱	2 9614 000	Gasket Set
⑲	2 9607 200	Cover Plate RPM Sensor Set
⑳	2 9407 300	Pressure Fitting
㉑	2 9613 000	Screw Set
㉒	7 4001 010	Electronic Control Unit (EC-2)
	2 9325 000	E-5010 Silencer Assembly
	2 9325 300	Assembly Set
	2 9325 400	Retaining Screw
	2 9326 000	Adaptor
	7 1608 001	Glow Plug No.8
	7 2403 061	Check Valve
	7 2403 060	Fuel Filter

INJECTOR AIR VALVE(70C) PARTS LIST

No.	Code No.	Description
①	2 7381 400	Throttle Lever Assembly
②	2 9483 210	Roter Valve
③	4 5581 820	Roter Guide Screw
④	2 9483 110	Injector Air Valve Body
⑤	2 9483 300	Injector Holder
⑥	2 9484 000	Injector Set
⑦	2 9015 019	Gasket

The specifications are subject to alteration for improvement without notice.

THREE VIEW DRAWING

Dimensions(mm)

Specifications

■ Displacement	26.23 cc(1.60cu.in.)
■ Bore	33.6 mm(1.323in)
■ Stroke	29.6 mm(1.165in)
■ Practical R.P.M.	1,800~9,000 r.p.m.
■ Output	3.7 ps / 8,500r.p.m.
■ Weight	945g (33.3oz.)
■ Silencer	E-5010 (300g 10.6oz)

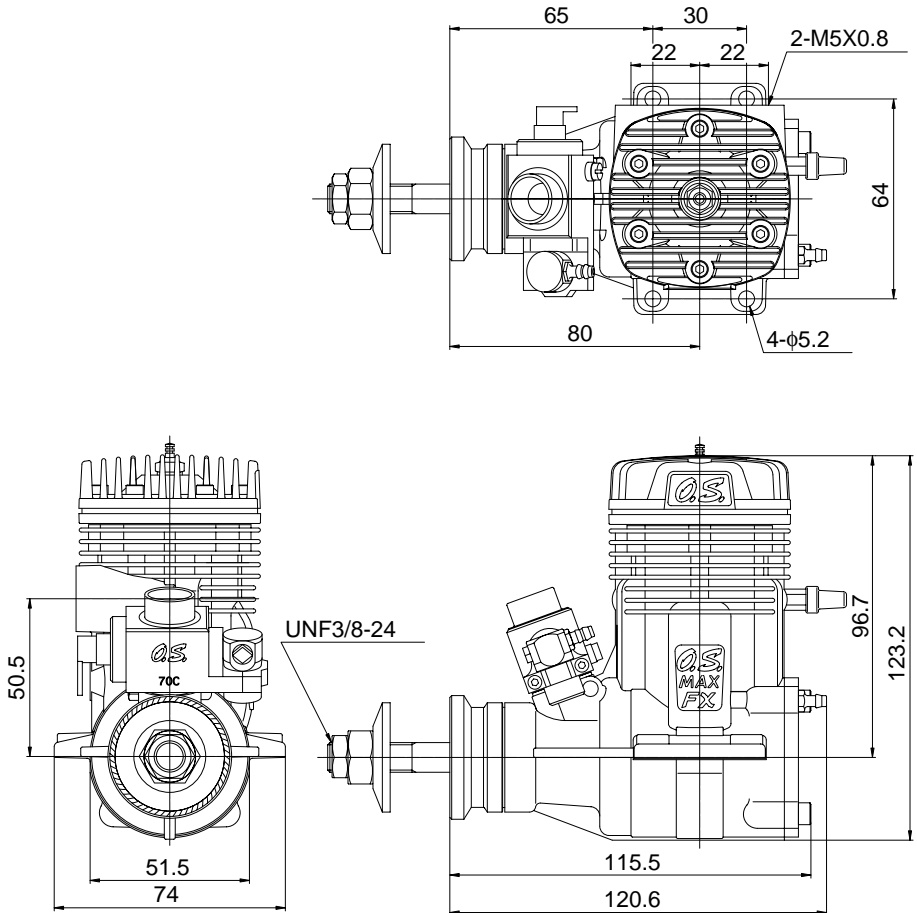

O.S. GENUINE PARTS & ACCESSORIES

■ O.S.GLOW PLUG

No.8
(71608001)

TYPE F
(71615009)

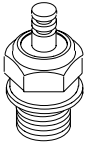

■ RADIAL MOTOR MOUNT

(71920000)

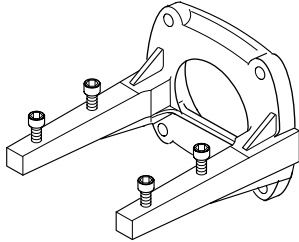

■ BOOSTER TERMINAL KIT

(72200130)



■ BOOSTER CABLE SET

(72200110)



■ PROPELLER LOCKNUT SET FOR TRUTURN SPINNER

3/8"-M5(S)
(29310110)



■ NON-BUBBLE WEIGHT

(71531000)



■ LOCK WASHER

(10sets)
M5(55500004)

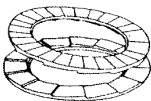

■ SUPER FILTER (L)

(72403050)

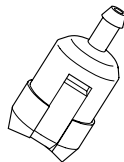

■ LONG SOCKET WRENCH WITH PLUG GRIP

(71521000)

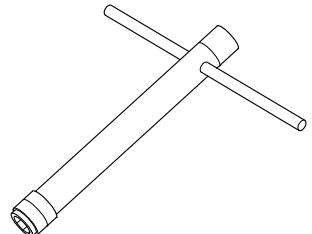



O.S. ENGINES MFG.CO.,LTD.

6-15 3-Chome Imagawa Higashisumiyoshi-ku
Osaka 546-0003, Japan TEL. (06) 6702-0225

FAX. (06) 6704-2722

URL : <http://www.os-engines.co.jp>